

# MASTER PNEUMATIC - DETROIT, INC.

## Filters, Regulators & Lubricators



## ServOil, Injection Lubrication



## Clean Air Systems



## Custom Special Products



Pneumatic Component Specialists

ISO 9001  
REGISTERED

# Master Pneumatic — The Most Respected Name in Pneumatic Products

For over 50 years Master Pneumatic has been bringing industry the finest in pneumatic products. Now we are proud to introduce our newest catalog showing the length and breadth of our product line. If any of your questions about our products are not answered here, your Master Pneumatic distributor will be pleased to assist you.

In addition to our fine products, we are well known for our commitment to customer service and satisfaction. Here are just a few of the reasons why our customers are pleased to deal with Master Pneumatic.

## WE HELP TO REDUCE YOUR INVENTORY NEEDS

Our "Just-in-Time" inventory program ensures a reliable supply of products to our wide network of distributors. This means that you don't have to maintain large stocks of parts. If a distributor should ever be temporarily out of any standard product, he can have it drop-shipped directly to you.

## ALL OUR PRODUCTS ARE FACTORY-TESTED

Our products are designed, produced, and then factory-tested so that they perform properly as soon as they are put into service. And this also means that they are built to give you long-term reliability. That is why Master Pneumatic products can be found in large and small plants in all parts of the world.

## WHEN PRODUCTS GO ABROAD, OUR SUPPORT GOES WITH THEM

We have been in export markets since 1960. Our products can be specified for overseas plants, or for use on OEM products shipped abroad, with the assurance that they are fully accepted, and supported by the worldwide network of Master Pneumatic distributors.

**We have been a proud member of the National Fluid Power Association for over thirty years.**

## WE WORK WITH YOU ON YOUR NEEDS FOR CUSTOMIZED PRODUCTS

Designing specialized products to satisfy special needs is one of our recognized strong points. One of our sales engineers will be pleased to discuss any of your unique pneumatic problems and offer a cost-effective solution.

## SEE OUR SEVEN-YEAR WARRANTY

Our seven-year product warranty is shown below. It is your assurance of our commitment to your complete satisfaction with our products.

### SEVEN-YEAR WARRANTY

The Company warrants to the Purchaser that the equipment described in this catalog will be free from defects in material and workmanship for seven years. This warranty does not cover normal service parts (such as filter elements) or parts that fail due to chemical attack\*, abuse, improper service, or improper use. This warranty does not cover product not manufactured by Master Pneumatic-Detroit, Inc. These products will be covered by the original manufacturer's warranty, if any. The foregoing warranty is exclusive and in lieu of all other warranties whether written, oral, express, or implied. There is NO WARRANTY OF MERCHANTABILITY OR FITNESS OF PURPOSE. If it appears within seven years from the date of shipment by the Company that the equipment has not met the warranties specified above and the purchaser notifies the Company promptly, the Company shall correct any defect, at its option, either by repairing any defective part or parts or by making available at the Company's plant a repaired or replacement part. Except as otherwise specified by manufacturer, these parts are specifically designed for compressed air service. Use with any other fluid must be approved by Master Pneumatic-Detroit, Inc.

In no event will Master Pneumatic-Detroit, Inc., be liable for business interruptions, loss of profits, harm, injury, damage, personal injury, cost of delay, or any special, indirect, incidental, or consequential losses, costs, or damages.

*\*It is extremely important that our products be used in a proper environment. Polycarbonate, acetal, nylon, ABS and other plastics are especially vulnerable to attack by certain chemicals and their fumes including compressor oils, cleaners, solvents, etc. When in doubt, please ask your chemical supplier if their products are injurious to the parts used in the Master Pneumatic products.*

**Please note the metal bowl options available in each product section.**

# CONTENTS

	Page
<b>SAFETY LOCKOUT and DELAYED-PRESSURE-BUILDUP VALVES</b>	
Custom Products.....	4-5
Lockout Valves.....	6-19
Delayed-Pressure-Buildup Valves .....	20-25
Combined Lockout and Delayed-Pressure-Buildup Valves.....	26-33
Shuttle Valves .....	36-37
Flow Control Valves.....	38-41
Check Valves .....	42-43
<b>FILTERS</b>	
General Purpose .....	44-69
Coalescing.....	70-93
Oil Vapor Removal (Adsorbing).....	94-99
Clean Air Packages.....	100-103
M/P Filenco Dryer/Filters .....	104-111
<b>PRESSURE REGULATORS</b>	
General Purpose .....	112-131
Precision.....	132-139
Externally Piloted .....	140-153
Water.....	154-157
Relief Valves.....	158-159
Electro-Pneumatic Servo-Valves.....	160-161
<b>INTEGRAL FILTER/REGULATORS</b> .....	162-175
<b>AIR LINE LUBRICATORS</b> .....	176-197
<b>INJECTION LUBRICATION</b> .....	
Servo-Meters .....	198
Controllers .....	199
Tool Lubrication .....	200
Single Point Lubricators for Air Tools .....	202-203
Single Point Downstream Lubricators .....	204-205
Cylinder Lubrication .....	206-207
FRLs with SPLs + Hose .....	208-209, 288
Multiple Point Lubricators.....	210-217
Automation Pacs .....	218-223
Scorpion.....	224-225
Viper Chain Lubricators.....	230-235
<b>LIQUID DISPENSERS</b> .....	236-237
(Series 740, 750, 760, 770)	
<b>FRLs</b>	
With Integral Filter/Regulator .....	226-229
Filter-Regulator-Lubricators .....	(Series 740, 750, 760, 770)
<b>ACCESSORIES</b>	
External Float-Actuated Drain.....	238, 240-253
Gauges.....	239, 254-273
Modular Connectors & Accessories.....	274-275
Mounting Brackets.....	276
Mufflers.....	277
PneuCool Scorpion Coolant .....	277
Pressure Sensors.....	284-286
Pressure/Vacuum Switches.....	282
Q-Caps.....	277
Series 380 Custom Interface .....	292
Series 380 FRL Ordering Information.....	291-292
Serv-Oil Accessories .....	288
Serv-Oil Reservoirs .....	287
Silencer/Reclassifiers .....	278-279
Tube-Away Kits.....	277
Warrior Drain.....	281
<b>INDEX</b> .....	293-294

## CATALOG SECTIONS

Catalog section locators are on the edges of the catalog pages, and are in three banks. Their arrangement is shown at the right.

3rd Bank	2nd Bank	1st Bank
Injection LUBRICATORS	sorbng Filters, Dryers, Clean Air Packages	LOCKOUT and DPB VALVES
CORPION and LIQUID DISPENSERS	Pressure REGULATORS	AUXILIARY EQUIPMENT
FRLs	Integral FILTER/REGULATORS	General Purpose FILTERS
ACCESSORIES	Air Line LUBRICATORS	Coalescing FILTERS

# CUSTOM PRODUCTS

For many years Master Pneumatic has participated in the development and manufacture of custom filters, regulators and lubrication systems. Designed as solutions for specific application problems, these custom products have ranged from simple, standard product modifications, using existing parts and minimal engineering time, to others requiring specialty parts and extensive engineering time.

Our sales staff, manufacturing team, and experienced engineers work to produce quality products that meet required

specifications. Our manufacturing equipment allows for quick response, with tested prototypes, for customer evaluation.

The units shown here illustrate some of the more than 700 specialty products we have already offered. We encourage you to inquire about possible specialized solutions for your individual application situation. A custom product request form, that may be copied and faxed, has been included on the facing page. Please note that some custom product development may have minimum quantity requirements.

## PILOT OPERATED MANIFOLD REGULATOR



## CO<sub>2</sub> FILTER-RELIEF VALVE WITH CHECK



## COMBINATION START-RUN AND CONTROL VALVE



## SPECIAL ANODIZED FILTER



# MASTER PNEUMATIC - DETROIT, INC. SPECIAL PRODUCT REQUEST FORM

Fax Number: (586) 254-6055

Date of Request: \_\_\_\_\_

Requested by: \_\_\_\_\_

Company Name: \_\_\_\_\_

Phone Number: \_\_\_\_\_ Fax: \_\_\_\_\_

Customer Requirements: \_\_\_\_\_

\_\_\_\_\_

\_\_\_\_\_

\_\_\_\_\_

\_\_\_\_\_

\_\_\_\_\_

\_\_\_\_\_

\_\_\_\_\_

\_\_\_\_\_

## DESIGN REQUIREMENTS

Media Used in Product: \_\_\_\_\_

Inlet Pressure: \_\_\_\_\_ Outlet Pressure: \_\_\_\_\_ Flow: \_\_\_\_\_ scfm

Are Buna N Seals Acceptable:  Yes  No

Maximum Temp.: \_\_\_\_\_ Minimum Temp.: \_\_\_\_\_

\_\_\_\_\_

## MISCELLANEOUS INFORMATION

\_\_\_\_\_

\_\_\_\_\_

\_\_\_\_\_

Is comparable product currently being used?:  Yes  No

Estimated Annual Usage: \_\_\_\_\_

\_\_\_\_\_

# LOCKOUT VALVES and DELAYED-PRESSURE-BUILDUP VALVES

## OSHA Requirements Clearly State, “Energy Isolating Devices, Such As Lockouts, Are Now Required.”

Federal regulation 29 CFR 1910.147 of the Occupational Safety and Health Administration (OSHA) details safety requirements for the control of hazardous energy during “... the servicing and maintenance of machines and equipment in which the unexpected ... startup ... could cause injury ...” Here are a few other highlights from the regulation:

**ENERGY SOURCE.** “Any source of electrical, mechanical, hydraulic, pneumatic, thermal, or other energy.”

**LOCKOUT DEVICE.** “A device that utilizes a positive means such as a lock, whether key or combination, to hold an energy isolating device in the safe position ...”

**PURPOSE.** “This section requires employers to establish a program and utilize procedures for affixing appropriate lockout devices . . . to prevent unexpected energization, startup or release of stored energy ...”

**TIMING.** “After October 31, 1989, whenever major replacement, repair, renovation or modification of machines or equipment are installed, energy isolating devices for such machines or equipment shall be designed to accept a lockout device.”

In short, each piece of equipment must have a shutoff valve to isolate the equipment from its air supply. The shutoff valve must be lockable in the closed position so that it cannot inadvertently be opened. When closed the shutoff valve must have an exhaust port to exhaust downstream pressurized air.

### LOCKOUT VALVES

Lockout valves are offered in a full range of port sizes, and with different actuation modes. Each valve is designed to satisfy the OSHA requirements for energy isolation

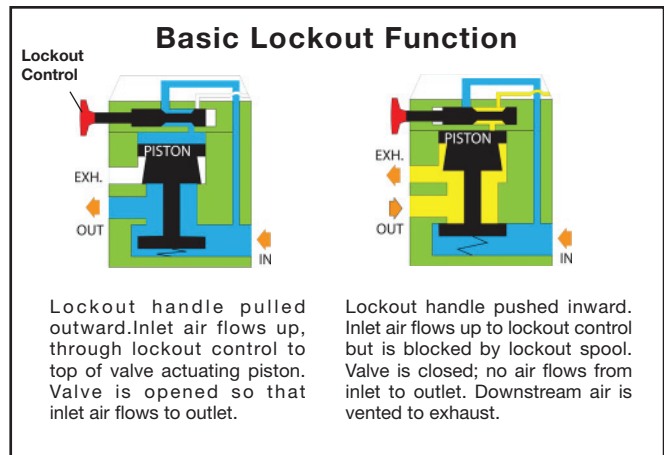

### GUIDE to LOCKOUT VALVES and DELAYED-PRESSURE-BUILDUP VALVES

Valve Series	Port Sizes										Pages	
	1/8	1/4	3/8	1/2	3/4	1	1-1/4	1-1/2	2	2-1/2		
<b>SENTRY</b> V10 Lockout Models †	X	X										10-11
<b>GUARDSMAN</b> V35 Lockout Models		X	X	X	X							12-13
<b>VANGUARD Lockout</b>												
V40 Manual Models			X	X	X	X	X					14-15
V450 Manual Pilot Models						X	X	X	X	X		16-17
V460 Solenoid Pilot Models		X	X	X	X	X	X	X	X	X		18-19
<b>DELAYED PRESSURE BUILDUP</b>												
V470 Air Pilot Models		X	X	X	X	X						20-21
V475 Solenoid Pilot Models		X	X	X	X	X						22-23
V495 Models		X	X	X	X	X	X	X				24-25
<b>LOCKOUT plus DELAYED PRESSURE BUILDUP</b>												
V45M Manual Models			X	X	X							26-27
V380 Slide Lockout Models			X	X	X							28-29
V480 Air Pilot Models		X	X	X	X	X						30-31
V485 Solenoid Pilot Models		X	X	X	X	X						32-33
<b>AUXILIARY VALVES</b> (Flow Control, Shuttle, Check)												34-43

† Also available with quick-connect tube fittings up to 10 mm.



and lockout. They are not, however, intended as emergency stop devices.

They lock out the supply air in a system with an easy pushing or sliding motion, and also exhaust downstream air pressure. Even after extended periods on standby, the valves are designed with seals and materials that

allow the lockout control to move smoothly into the lockout position.

All Master Pneumatic lockout valves can be secured in the closed position by means of a padlock so that the valve cannot be inadvertently opened to cause a potentially hazardous situation. Shown above is one of the manual lockout valves padlocked in the closed position.

**SENTRY V10 SLIDE LOCKOUT VALVE.**

This lockout valve was developed for use with the **SENTRY** series of modular **FRLs**. A slide controls the lockout function. Sentry modules and assemblies are available with this valve installed, or the valve can be retrofitted in the field.



As a separate component the **SENTRY** lockout valve is available with a choice of two pipe sizes and six sizes of quick-connect tube fittings.

**GUARDSMAN V35 SLEEVE LOCKOUT VALVE.**



This valve has a sliding sleeve to control the lockout function. A built-in slide latch holds the lockout control in the closed

position, and for further security the valve can be padlocked in this position. The valve has the built-in colors safety yellow and caution red to make the valve conspicuous in the workplace. The operating sleeve resists accidental shutoff, yet because it is Teflon-coated it slides without sticking even after a long period on standby.

The V35 valve is available in port sizes from 1/4 to 3/4 and with flow coefficients ( $C_v$ ) from 2.4 to 7.3.

**VANGUARD V40 MANUAL LOCKOUT VALVE**

The valve has a large red operating handle for high visibility. A short inward push of the handle closes off the flow of air, and quickly exhausts downstream air. The exhaust port is threaded for the installation of a silencer or a line for remote exhausting. Of course, the valve can be padlocked in the closed position.



The V40 valve is built in two body sizes with port sizes from 3/8 to 1-1/4. Flow coefficients ( $C_v$ ) range from 6 to 20 so that these valves are useful in a wide range of applications.

**VANGUARD V450 and V460 PILOTED VALVES with LOCKOUT CONTROL.**

Series V450 valves are air piloted valves, while the Series V460 valves employ a solenoid pilot. Both valves can be operated remotely. In other respects the valves are similar.



(continued on next page)

They are 3-way poppet valves with a lockout control interposed between the pilot signal and the valve's actuating poppet. The lockout control has a conspicuous red handle which, when pushed inward, cuts off the pilot signal and renders the valve inoperative. The handle can then be padlocked for complete safety.

The V450 valves are built in two body sizes with port sizes ranging from 1 to 2-1/2, and flow coefficients ( $C_v$ ) ranging from 23 to 70. The V460 valves are built in four body sizes with port sizes ranging from 1/4 to 2-1/2, and flow coefficients ( $C_v$ ) ranging from 2.5 to 70, making them suitable for nearly all applications. See individual product page for available voltages.

### DELAYED-PRESSURE-BUILDUP VALVES

When actuated, valves with the delayed-pressure-buildup (DPB) feature allow a gradual buildup of downstream air pressure. This allows cylinders and other work elements to move slowly and more safely into their normal working positions. After downstream pressure has reached a certain level the valve opens fully and downstream pressure is at its maximum level.

The DPB function is achieved by requiring the initial flow of air to pass through a restricted orifice so that the buildup of downstream pressure is slowed. The restricted orifice may be fixed or adjustable to control the rate of pressure buildup. The change of air flow from restricted to full flow is accomplished either manually or by a built-in timing device. The functioning of a basic valve with DPB is shown in the sketches at the bottom of the page.

Some of the DPB valves described below also have a lockout control, so that they serve the double functions of delayed-pressure-buildup and lockout control. Those with the added lockout feature can all be padlocked in the closed position.

### SERIES V470 and V475 DELAYED-PRESSURE-BUILDUP VALVES.

Series V470 valves are air piloted valves, while the Series V475 valves employ solenoid pilots to permit remote control. In other respects they are similar.

They are 3-way poppet valves with a DPB device interposed between the pilot signal and the valve's actuating poppet. An adjustable control determines the rate of delayed pressure buildup. There is also an exhaust port through which downstream air is exhausted when the valve is de-energized. Threads in the exhaust port allow the installation of a silencer or a line for remote exhausting.

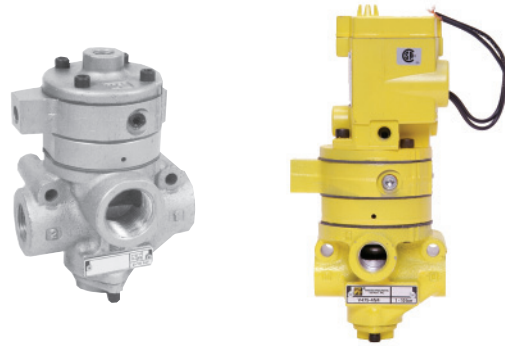

### DELAYED-PRESSURE-BUILDUP (DPB) FUNCTION

The illustrations below show the DPB function of a 2-way valve. They show the use of a restricted orifice to delay pressure buildup and to "time" the full opening of the valve. Three-way valves require a slightly more complex arrangement, and also have the advantage of a specific port for exhausting downstream air. See following pages for operating details of other DPB valves.

When air pressure is first applied to the inlet, air flow to the actuating piston is restricted by the needle. Downstream pressure gradually builds up at a rate determined by the needle setting.

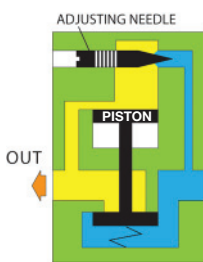

When downstream pressure reaches a certain percentage of inlet pressure, it is enough to actuate the valve's piston and the inlet poppet opens. The valve is now open to full air flow.

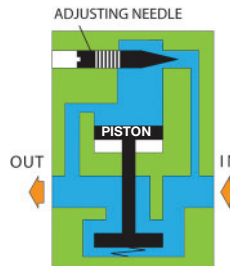

When inlet pressure is removed, downstream air is exhausted through the inlet port and around the point of the adjusting needle.

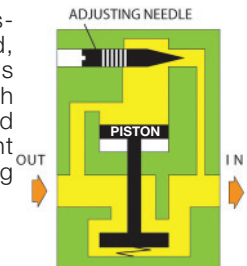



These valves should be used in conjunction with lockout valves.

They are built in two body sizes with port sizes ranging from 1/4 to 1, and flow coefficients ( $C_v$ ) ranging from 2.5 to 8. See individual product page for available voltages.

**SERIES V495 DELAYED-PRESSURE-BUILDUP VALVES.**

A V495 valve is a 2-way valve with a **DPB** function. An adjustable restrictor within the valve determines the buildup rate of downstream air pressure. When downstream pressure reaches approximately 40% to 60% of inlet pressure, the valve shifts to the fully open position. The V495 valves should be used in conjunction with lockout valves.



The valves are made in three body sizes with ports ranging from 1/4 to 1-1/2, and flow coefficients ( $C_v$ ) from 2.3 to 29.

**SERIES V45M MANUAL LOCKOUT plus DELAYED-PRESSURE-BUILDUP VALVES.**

When opened by an outward pull of its blue handle, the valve allows a gradual buildup of downstream air pressure. It opens to full flow when it's outlet pressure is 25 psi less than it's inlet pressure. An adjustable screw in the top of it's handle sets the rate of pressure buildup.

When the handle is pushed inward the valve's lockout function is like that of the V40 lockout valve described above. Inlet air is blocked, and downstream air is exhausted.

The valves have ports ranging from 3/8 to 3/4, and flow coefficients ( $C_v$ ) from 6 to 8.6.



**SERIES V380 SLIDE LOCKOUT plus DELAYED-PRESSURE-BUILDUP VALVES.**

The V380 valve is specifically designed to be used with Series 380 **FRL's**. It is modularly connected to the FRL, and can be rotated to any of eight positions for the most convenient operation.

A sliding Delrin plate with a detent is used to go from the closed position, to the delayed-pressure-buildup position, and then to the fully open position. An override button must be depressed to move from the **DPB** position to the fully open position. If a fast start is required, the slide can be moved directly from the closed to the fully open position by holding the override button down, while lifting the slide.



**SERIES V480 and V485 LOCKOUT plus DELAYED-PRESSURE-BUILDUP VALVES.**

Series V480 valves are air piloted valves, while the Series V485 valves employ solenoid pilots. Both allow remote control. In other respects the valves are similar.

They are 3-way poppet valves with both lockout and **DPB** devices interposed between the pilot signal and the valve's actuating piston. When the handle on the lockout control is pulled outward the **DPB** function allows a gradual buildup of downstream air pressure before the valve opens to full flow. An adjustable control determines the rate of pressure buildup. There is also an exhaust port through which downstream air is exhausted when the valve is de-energized or the lockout control is actuated. Threads in the exhaust port allow the installation of a silencer or a line for remote exhausting.

When the handle of the lockout control is pushed inward the valve's lockout function is like that of the V470 or V475 lockout valves described above. Inlet air is blocked, and downstream air is exhausted.

These valves are built in two body sizes with port sizes ranging from 1/4 to 1, and flow coefficients ( $C_v$ ) ranging from 2.5 to 8. See individual product page for available voltages.



# SENTRY Slide Lockout Valves

## V10 Models Port Sizes: 1/8, 1/4 Tube Fittings

Model Shown: V10-2



- ◆ 3-Way lockout valve specifically for use with **SENTRY FRL's**
- ◆ Threaded ports or quick-connect fittings for tubing up to 10 mm in diameter.
- ◆ Available pre-assembled on **FRL** assembly, or as a single component for retrofitting in the field.
- ◆ Can be padlocked only in the closed position.
- ◆ Slide moves smoothly even after long period on standby.
- ◆ **NPTF** port threads; optional **BSPP** threads or tube fittings.

### SPECIFICATIONS

**Ambient/Media Temperature:**

40° to 125°F (4° to 52°C).

**Elastomers:** Nitrile.

**Fluid Media:** Compressed air.

**Inlet Pressure:** 150 psig (10 bar) maximum.

**Screws:** Zinc-plated steel.

**Slide:** Acetal.

**Valve Color:** Yellow.

### FLOW CHART

Inlet Pressure: 100 psig (7 bar)

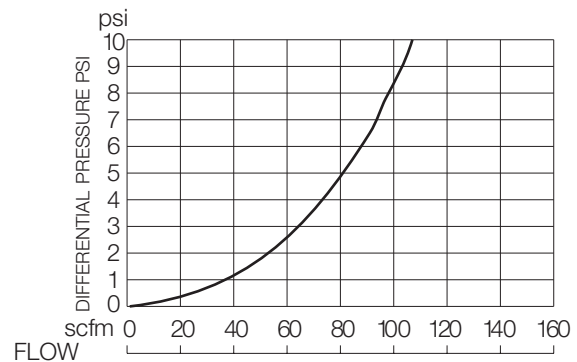

### VALVE OPERATION

#### VALVE OPEN

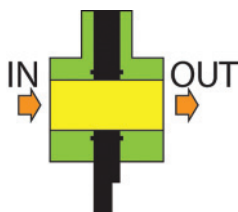

With the yellow slide depressed, supply air flows freely from inlet to outlet, and flow to the exhaust is blocked. The slide cannot be padlocked in the open position so that it is always ready for immediate closing.

#### VALVE CLOSED

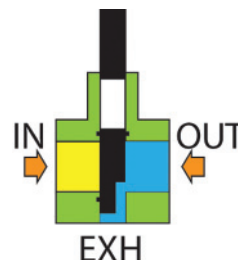

With the slide fully pushed out, supply air is blocked from the outlet, and downstream air is exhausted via the opening at the bottom of the valve. The slide can be padlocked in the closed position.

## DIMENSIONS inches (mm)

Ports	A	B	C
No Ports	1.8 (45)	2.3 (57)	0.6 (14)
1/8, 1/4	1.8 (45)	2.5 (64)	2.0 (51)

### Models below have quick-connect fittings for tubing.

1/4	1.8 (45)	2.5 (64)	2.3 (58)
3/8	1.8 (45)	2.5 (64)	2.9 (74)
4 mm	1.8 (45)	2.5 (64)	2.5 (64)
6 mm	1.8 (45)	2.5 (64)	2.1 (53)
8 mm	1.8 (45)	2.5 (64)	2.1 (53)
10 mm	1.8 (45)	2.5 (64)	2.9 (74)

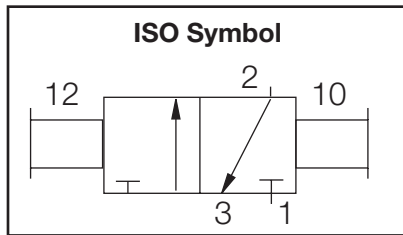

**WALL MOUNTING:** To mount a complete valve with threaded ports or tube fittings, use two 10-24 x 2-1/4" pan-head Philips screws (Part number 10R-19)

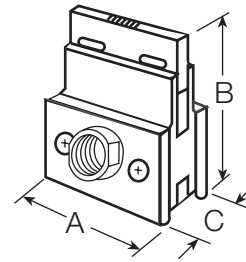

## ASSEMBLED SENTRY UNITS

Assembled **SENTRY FRLs** with V10 lockout at the inlet can be ordered. Model VCFDRL10-2 is shown below.

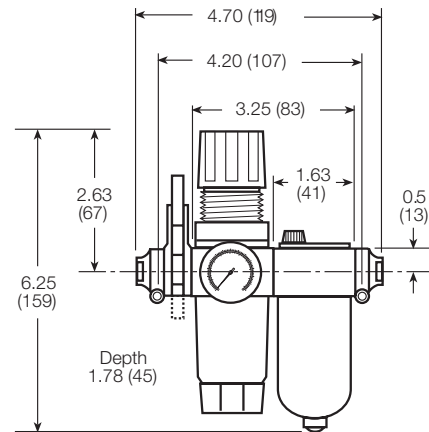

## ORDERING INFORMATION

Change the letters in the sample model number below to specify the valve you want.  
To order V10 lockouts installed on a **SENTRY FRL**, see Options on **FRL** pages.

### V10 P - 1 X W

#### MOUNTING HOLE LOCATION

Bottom mount (Standard) ..... Leave Blank  
Top mount ..... P

#### INLET PORT SIZE

No Inlet and Outlet fittings..... Leave Blank  
*Includes seals and screws for retrofitting.*

#### Threaded:

1/8 NPTF ..... -1  
1/4 NPTF ..... -2

#### Fittings for Tubing:

1/4 ..... -04  
3/8 ..... -06  
4 mm ..... -M4  
6 mm ..... -M6  
8 mm ..... -M8  
10 mm ..... -M10

#### PORT TYPE

As specified in **INLET PORT** .... Leave Blank  
BSPP threads on both ports ..... W

#### OUTLET PORT SIZE

Same as inlet port ..... Leave Blank

#### Threaded:

1/8 NPTF ..... 1  
1/4 NPTF ..... 2

#### Fittings for Tubing:

1/4 ..... 04  
3/8 ..... 06  
4 mm ..... M4  
6 mm ..... M6  
8 mm ..... M8  
10 mm ..... M10

# GUARDSMAN Sleeve Lockout Valves

# V35 Models Port Sizes: 1/4 to 3/4

Model Shown: V35-2



- ◆ 3-Way lockout valve specifically for use with **GUARDSMAN FRLs**.
- ◆ Each unit has a safety yellow barrel and a caution red slide.
- ◆ Can be padlocked only in the closed position.
- ◆ Sleeve rotates for most convenient location of padlock.
- ◆ Sleeve moves smoothly even after long period on standby.
- ◆ Controlled exhaust rate muffles exhaust noise.
- ◆ **NPTF** port threads; optional **BSPP** threads.

## SPECIFICATIONS

**Ambient/Media Temperature:**

40° to 125°F (4° to 52°C).

**Body:** Nylon and Aluminum.

**Fluid Media:** Compressed air.

**Inlet Pressure:** 150 psig (10 bar) maximum.

**Lock Mechanism:** Nylon.

**Sleeve:** Nylon.

**Valve Color:** Safety yellow and caution red.

## FLOW CHART

Inlet Pressure: 100 psig (7 bar)

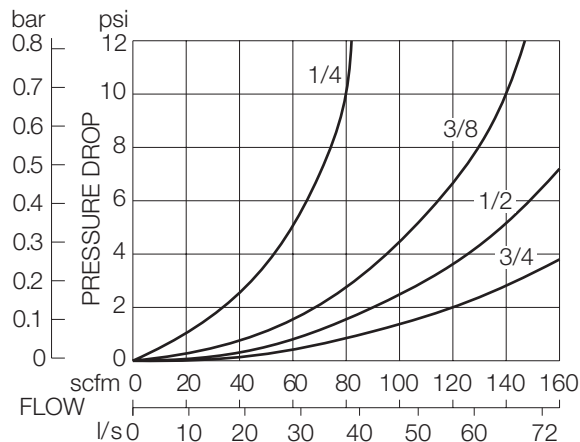

## VALVE OPERATION

### VALVE OPEN

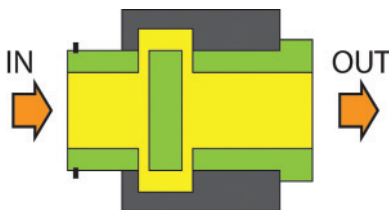

With the sleeve in the open position (against the stop at the outlet port), supply air flows freely from inlet to outlet, and flow to the exhaust is blocked. The sleeve cannot be padlocked in the open position so that it is always ready for immediate closing.

### VALVE CLOSED

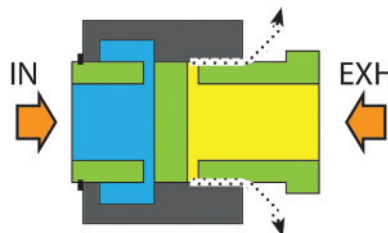

With the sleeve in the closed position (against the stop at the inlet port), supply air is blocked from the outlet, and downstream air is exhausted to atmosphere. A built-in sliding latch can be used to keep the valve in the closed position. In addition the sleeve can be padlocked in the closed position.

**DIMENSIONS** inches (mm)

Port Size	Average C <sub>v</sub>	A	B	C
1/4	2.4			
3/8	4.6	2.7	2.3	2.2
1/2	5.9	(68)	(59)	(56)
3/4	7.3			

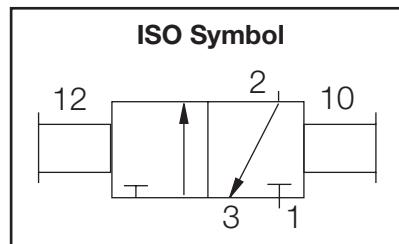
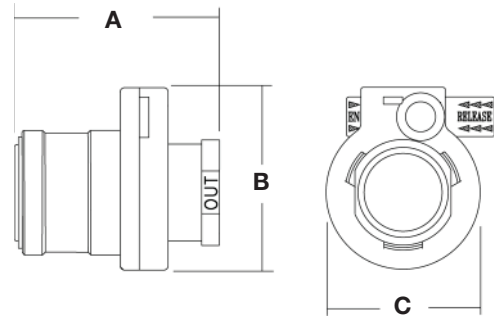

**ORDERING INFORMATION**

Select the port size in the sample model number below to specify the valve you want.

**V35 - 2 W**

**PORT SIZE**

1/4 NPTF .....2

3/8 NPTF .....3

1/2 NPTF .....4

3/4 NPTF .....6

**PORT TYPE**

NPTF Threads ..... Leave Blank

BSPB threads ..... W

# VANGUARD Manual Lockout Valves

## V40 Models Port Sizes: 3/8 to 1-1/4



Model Shown: V40-3N8

- ◆ 3-Way spool lockout valve. Available in two body sizes and five port sizes.
- ◆ Large operating handle is red so it will be easily seen in the workplace.
- ◆ Can be padlocked only in the closed position.
- ◆ Spool moves smoothly even after a long period on standby.
- ◆ Threaded exhaust port to accommodate a silencer or a line for remote exhausting.
- ◆ NPTF port threads; optional BSPP threads.

### SPECIFICATIONS

**Ambient/Media Temperature:**

40° to 175°F (4° to 80°C).

**Fluid Media:** Compressed air.

**Inlet Pressure:** 15 to 150 psig (1 to 10 bar).

### VALVE OPERATION

#### VALVE OPEN

With the red handle pulled outward, supply air flows freely from inlet to outlet, and flow to the exhaust is blocked. The sleeve cannot be padlocked in the open position so that it is always ready for immediate closing.

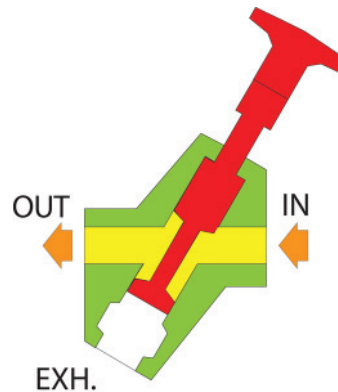

#### VALVE CLOSED

With a short inward push of the red handle, supply air is blocked from the outlet, and downstream air is exhausted to atmosphere via the exhaust port at the bottom of the valve. The valve can be padlocked in the closed position.

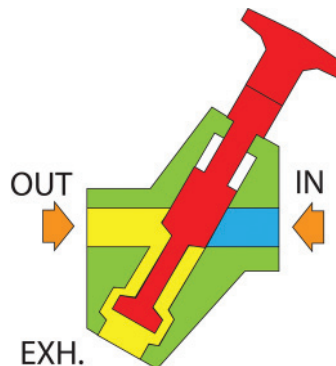

**DIMENSIONS** inches (mm)

Port Sizes		Average C <sub>v</sub>		A	B	C
In-Out	Exh	1 to 2	2 to 3			
3/8	3/4	6.0	8.0	6.4 (163)	8.8 (224)	2.0 (51)
1/2	3/4	7.1	8.3			
3/4	3/4	8.6	9.5			
3/4	1-1/4	13	12	7.7 (196)	10.8 (274)	2.3 (58)
1	1-1/4	13	14			
1-1/4	1-1/4	20	14			

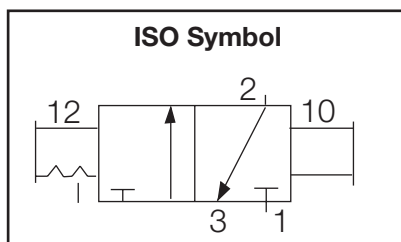
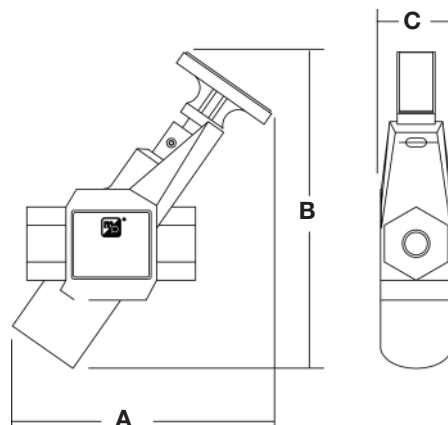

**ORDERING INFORMATION**

Select the port sizes in the sample model number below to specify the valve you want.

**V40 - 3 N6 W**

**INLET/OUTLET PORTS**

- 3/8 NPTF ..... 3
- 1/2 NPTF ..... 4
- 3/4 NPTF ..... 6
- 1 NPTF ..... 8
- 1-1/4 NPTF ..... 10

**PORT TYPE**

- NPTF Threads ..... Leave Blank
- BSPP threads ..... W

**EXHAUST PORT SIZE:**

- 3/4 exhaust port ..... N6  
for 3/8, 1/2, 3/4 inlet / outlet ports
- 1-1/4 exhaust port ..... N10  
for 3/4, 1, 1-1/4 inlet / outlet ports

# VANGUARD Manual Pilot 3/2 Valves with Lockout Control

# V450 Models Port Sizes: 1 to 2-1/2

Model Shown: V450-8N12

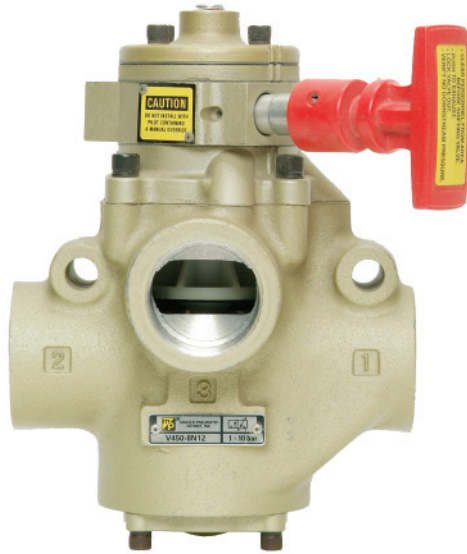

- ◆ 3-Way poppet valve. Available in two body sizes and five port sizes.
- ◆ Large operating handle is red so it will be easily seen in the workplace.
- ◆ Can be padlocked only in the closed position.
- ◆ Lockout spool moves smoothly even after long period on standby.
- ◆ Threaded exhaust port to accommodate a silencer or a line for remote exhausting.
- ◆ NPTF port threads; optional BSPP threads.

## VALVE OPERATION

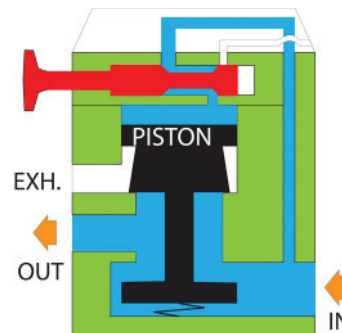

### VALVE OPEN

With the red handle pulled outward, supply air flows to the top of the piston causing it to open the inlet poppet. Supply air then flows freely from inlet to outlet, and the exhaust port is blocked.

## SPECIFICATIONS

### Ambient/Media Temperature:

40° to 175°F (4° to 80°C).

**Fluid Media:** Compressed air.

**Inlet Pressure:** See DIMENSIONS for port sizes.

1-1/2 exhaust port: 15 to 150 psig (1 to 10 bar).

2-1/2 exhaust port: 30 to 150 psig (2 to 10 bar).

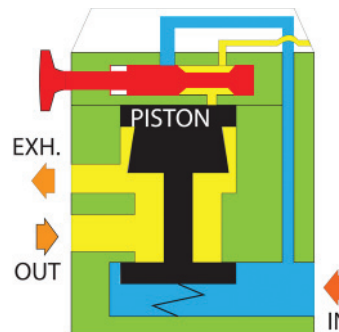

### VALVE CLOSED

With a short inward push of the red handle, supply air is blocked from the outlet, and downstream air is exhausted to atmosphere via the exhaust port. The valve can be padlocked in the closed position.



**DIMENSIONS** inches (mm)

Port Sizes In-Out	Exh	Average C <sub>v</sub>		A	B	C
		1 to 2	2 to 3			
1	1-1/2	23	34			
1-1/4	1-1/2	30	32	7.6 (193)	8.5 (216)	6.6 (166)
1-1/2	1-1/2	30	31			
1-1/2	2-1/2	68	70			
2	2-1/2	70	70	8.8 (222)	10.5 (267)	7.1 (180)
2-1/2	2-1/2	70	71			

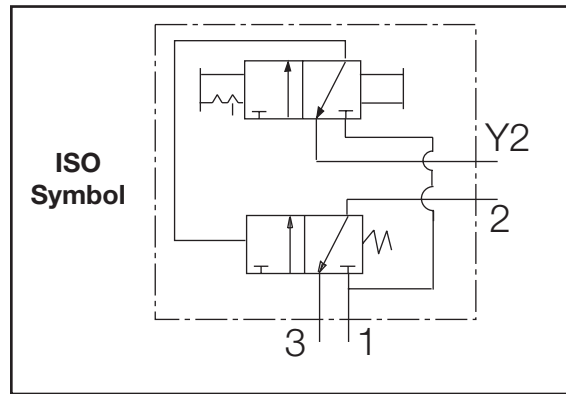
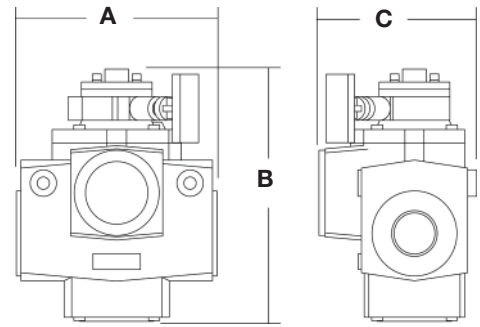

**ORDERING INFORMATION**

Select the port sizes in the sample model number below to specify the valve you want.

**V450 - 8 N12 W**

**INLET/OUTLET PORTS**

- 1 NPTF..... 8
- 1-1/4 NPTF ..... 10
- 1-1/2 NPTF ..... 12
- 2 NPTF..... 16
- 2-1/2 NPTF ..... 20

**PORT TYPE**

- NPTF Threads ..... Leave Blank
- BSP threads ..... W

**EXHAUST PORT SIZE:**

- 1-1/2 exhaust port.....N12  
for 1, 1-1/4, 1-1/2 inlet / outlet ports
- 2-1/2 exhaust port.....N20  
for 1-1/2, 2, 2-1/2 inlet / outlet ports

# VANGUARD Solenoid Pilot 3/2 Valves with Lockout Control

# V460 Models Port Sizes: 1/4 to 2-1/2

Model Shown: V460-8N8

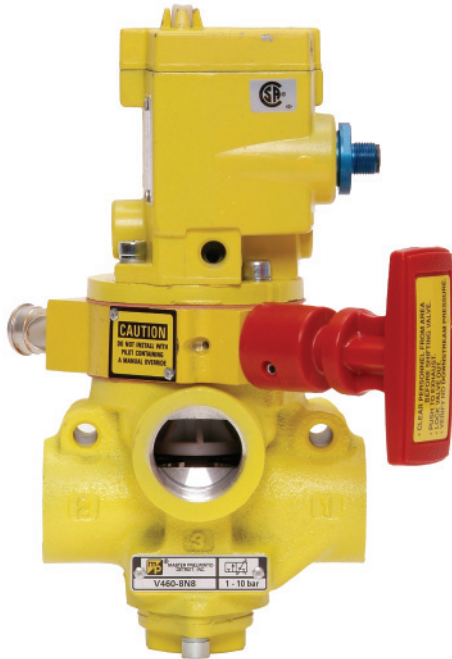

- ◆ 3-Way poppet valve. Available in four body sizes and nine port sizes.
- ◆ Solenoid pilot for remote control.
- ◆ Solenoids CSA approved.
- ◆ Large lockout handle is red so it will be easily seen in the workplace.
- ◆ Can be padlocked only in the closed position.
- ◆ Lockout spool moves smoothly even after long period on standby.
- ◆ Threaded exhaust port to accommodate a silencer or a line for remote exhausting.
- ◆ NPTF port threads; optional BSPP threads.

## SPECIFICATIONS

### Ambient/Media Temperature:

40° to 175°F (4° to 80°C).

**Fluid Media:** Compressed air.

### Inlet Pressure:

15 to 150 psig (1 to 10 bar) except largest body which is 30 to 150 psig (2 to 10 bar).

**Solenoid Voltages:** 110 volts 50/60 Hz standard.

Optional available voltages shown on following page.

## VALVE OPERATION

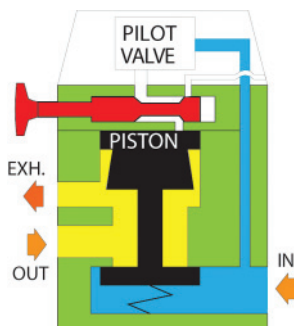

With solenoid pilot de-energized the inlet poppet is always closed. Downstream air pressure is exhausted via the exhaust port.

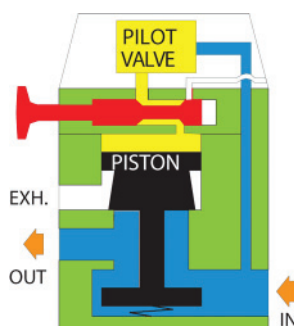

With solenoid pilot energized and the lockout handle pulled outward, pressure on the piston opens the inlet poppet and air flows freely from inlet to outlet. The exhaust port is closed.

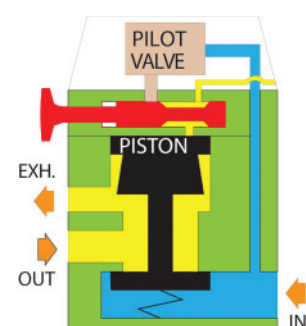

With the lockout handle pushed inward air to the piston is cut off. The inlet poppet closes, and downstream air pressure is exhausted via the exhaust port.

**DIMENSIONS** inches (mm)

Port Sizes		Average $c_v$		A	B	C
In-Out	Exh	1 to 2	2 to 3			
1/4	1/2	2.5	3.1			
3/8	1/2	3.6	5.3	6.1 (153)	8.2 (208)	6.3 (160)
1/2	1/2	3.3	5.3			
1/2	1	6.3	9.2			
3/4	1	7.7	11	6.6 (167)	8.9 (227)	6.3 (160)
1	1	8.0	12			
1	1-1/2	23	34			
1-1/4	1-1/2	30	32	7.6 (193)	11.5 (291)	6.6 (166)
1-1/2	1-1/2	30	31			
1-1/2	2-1/2	68	70			
2	2-1/2	70	70	8.8 (222)	13.4(339)	7.1 (180)
2-1/2	2-1/2	70	71			

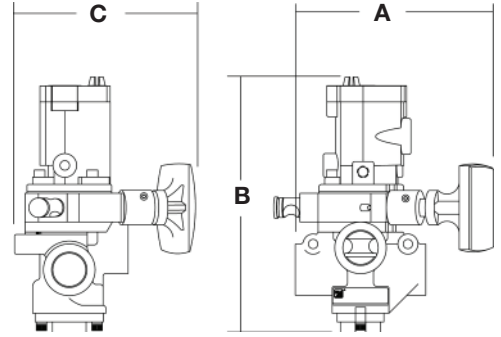

**LOCKOUT  
and DPB VALVES**

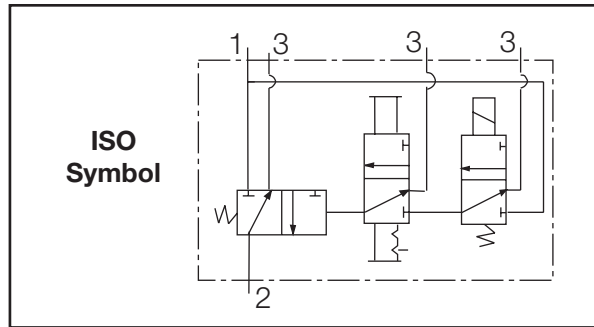

**ORDERING INFORMATION**

Select the port sizes in the sample model number below to specify the valve you want.

**V460 - A - 2 N4 W**

**VOLTAGE REQUIREMENT**

- 110/50Hz, 110-120/60Hz (AC)..... Leave Blank
- 12/50-60Hz (AC) ..... A
- 24/50-60Hz (AC) ..... B
- 48/50-60Hz (AC) ..... C
- 220/50, 220-240/60Hz (AC) ..... D
- 12v (DC) ..... E
- 24v (DC) ..... F
- 48v (DC) ..... G
- 120v (DC) ..... H

**INLET/OUTLET PORTS**

- 1/4 NPTF..... 2
- 3/8 NPTF..... 3
- 1/2 NPTF..... 4
- 3/4 NPTF..... 6
- 1 NPTF..... 8
- 1-1/4 NPTF ..... 10
- 1-1/2 NPTF ..... 12
- 2 NPTF..... 16
- 2-1/2 NPTF ..... 20

**PORT TYPE**

- NPTF Threads ..... Leave Blank
- BSP threads ..... W

**EXHAUST PORT SIZE:**

- 1/2" exhaust port.....N4  
for 1/4, 3/8, 1/2 inlet / outlet ports
- 1" exhaust port.....N8  
for 1/2, 3/4, 1 inlet / outlet ports
- 1-1/2" exhaust port ..... N12  
for 1, 1-1/4, 1-1/2 inlet / outlet ports
- 2-1/2" exhaust port .....N20  
for 1-1/2, 2, 2-1/2 inlet / outlet ports

# VANGUARD Remote Air Pilot 3/2 Valves with V470 Models

## Delayed-Pressure-Buildup Function Port Sizes: 1/4 to 1

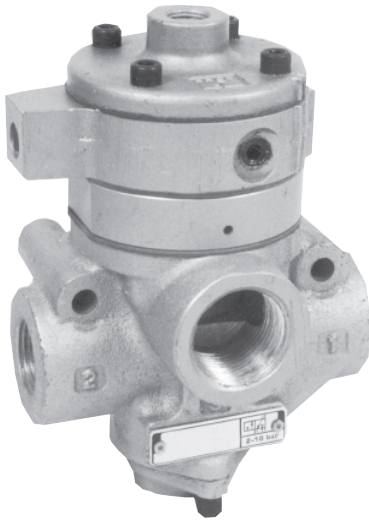

Model Shown: V470-2N4

- ◆ Delayed pressure buildup (DPB); rate of pressure buildup adjustable.
- ◆ 3-Way poppet valve. Available in two body sizes and five port sizes.
- ◆ Uses remote pilot control.
- ◆ Threaded exhaust port to accommodate a silencer or a line for remote exhausting.
- ◆ NPTF port threads; optional BSPP threads.

### SPECIFICATIONS

**Ambient/Media Temperature:**

40° to 175°F (4° to 80°C).

**Fluid Media:** Compressed air.

**Inlet Pressure:** 15 to 150 psig (1 to 10 bar).

### VALVE OPERATION

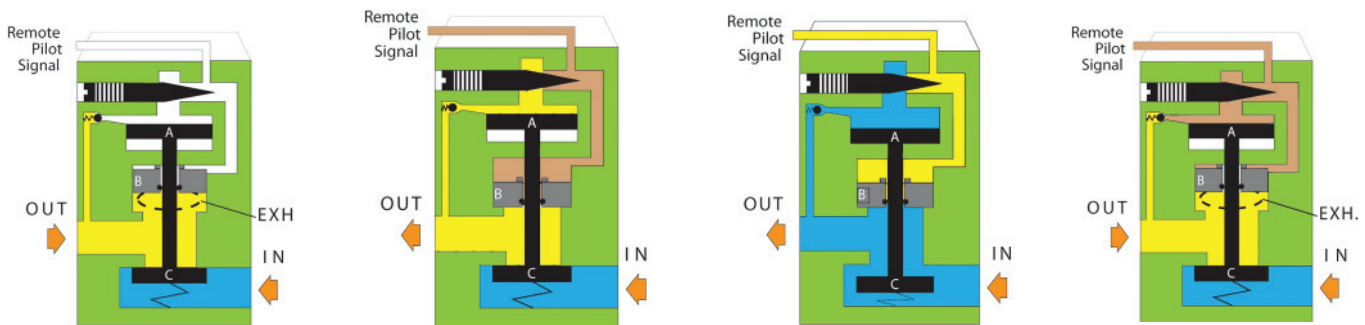

**No pilot signal.** Inlet air is blocked by poppet C. Piston B slides on the valve stem and is pushed upward if there is any downstream pressure. This opens the exhaust and vents the downstream line.

**Pilot signal applied.** Pilot air forces piston B downward to close exhaust port. Pilot air also flows past the metering pin, and slowly pressurizes the outlet line. Pressure is also building up on piston A.

When the pressure on piston A reaches 50% of inlet pressure, the piston is forced downward, opening inlet poppet C. Full inlet pressure now flows freely to the outlet port.

**Pilot signal removed.** Air above pistons A and B is exhausted through the exhaust port of the remote pilot valve. Air above poppet C forces sliding piston B up so that the main exhaust port is opened and pressurized air is exhausted.

**DIMENSIONS** inches (mm)

Port Sizes		Average $c_v$		A	B	C
In-Out	Exh	1 to 2	2 to 3			
1/4	1/2	2.5	3.1			
3/8	1/2	3.6	5.3	4.2 (107)	5.3 (136)	3.2 (79)
1/2	1/2	3.3	5.3			
1/2	1	6.3	9.2			
3/4	1	7.7	11	4.7 (118)	6.1 (155)	3.6 (92)
1	1	8.0	12			

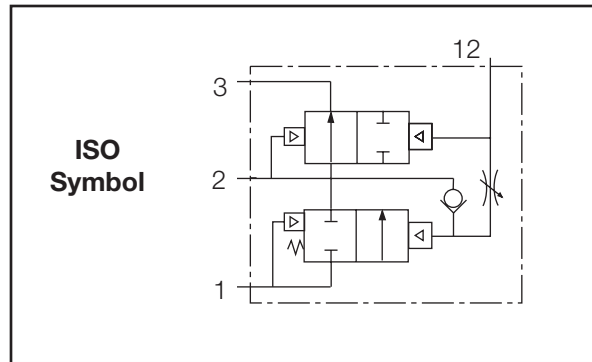
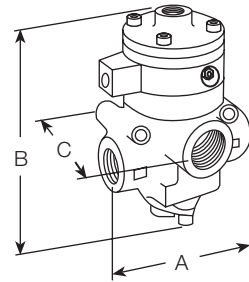

**ORDERING INFORMATION**

Select the port sizes in the sample model number below to specify the valve you want.

**V470 - 2 N4 W**

**INLET/OUTLET PORTS**

- 1/4 NPTF..... 2
- 3/8 NPTF..... 3
- 1/2 NPTF..... 4
- 3/4 NPTF..... 6
- 1 NPTF..... 8

**PORT TYPE**

- NPTF Threads ..... Leave Blank
- BSPP threads ..... W

**EXHAUST PORT SIZE:**

- 1/2 exhaust port ..... N4  
1/4, 3/8, 1/2 inlet / outlet ports
- 1 exhaust port ..... N8  
1/2, 3/4, 1 inlet / outlet ports

# VANGUARD Solenoid Pilot 3/2 Valves with Delayed-Pressure-Buildup Function

# V475 Models Port Sizes: 1/4 to 1

Model Shown: V475-4N4



- ◆ Delayed pressure buildup (DPB); rate of pressure buildup adjustable.
- ◆ 3-Way poppet valve. Available in two body sizes and five port sizes.
- ◆ Solenoid pilot allows remote control.
- ◆ Solenoids CSA approved.
- ◆ Threaded exhaust port to accommodate a silencer or a line for remote exhausting.
- ◆ NPTF port threads; optional BSPP threads.

## SPECIFICATIONS

### Ambient/Media Temperature:

40° to 175°F (4° to 80°C).

**Fluid Media:** Compressed air.

**Inlet Pressure:** 15 to 150 psig (1 to 10 bar).

**Solenoid Voltages:** 110 volts 50/60 Hz standard.  
Optional available voltages shown on following page.

## VALVE OPERATION

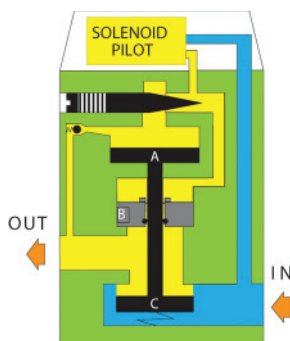

**Solenoid not energized.** Inlet air is blocked by poppet C. Piston B slides on the valve stem and is pushed upward if there is any downstream pressure. This opens the exhaust and vents the downstream line.

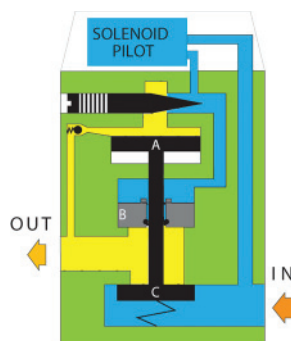

**Solenoid energized.** Pilot air forces piston B downward to close exhaust port. Pilot air also flows past the metering pin, opens the ball check, and slowly pressurizes the outlet line. Pressure is also building up on piston A.

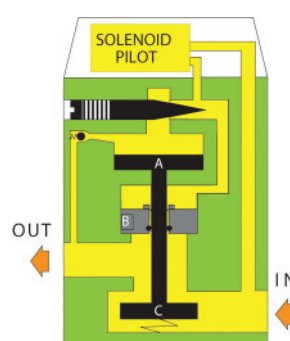

When the pressure on piston A reaches 50% of inlet pressure, the piston is forced downward, opening inlet poppet C. Full inlet pressure now flows freely to the outlet port.

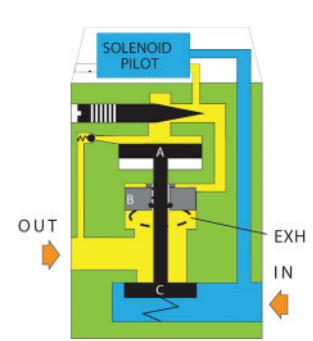

**Solenoid de-energized.** Air above pistons A and B is exhausted through the exhaust port of the pilot valve. Air above poppet C forces sliding piston B up so that the main exhaust port is opened and pressurized air is exhausted.

**DIMENSIONS inches (mm)**

Port Sizes		Average C <sub>v</sub>		A	B	C
In-Out	Exh	1 to 2	2 to 3			
1/4	1/2	2.5	3.1			
3/8	1/2	3.6	5.3	4.2 (107)	8.8 (224)	3.2 (79)
1/2	1/2	3.3	5.3			
1/2	1	6.3	9.2			
3/4	1	7.7	11	4.7 (118)	9.6 (243)	3.6 (92)
1	1	8.0	12			

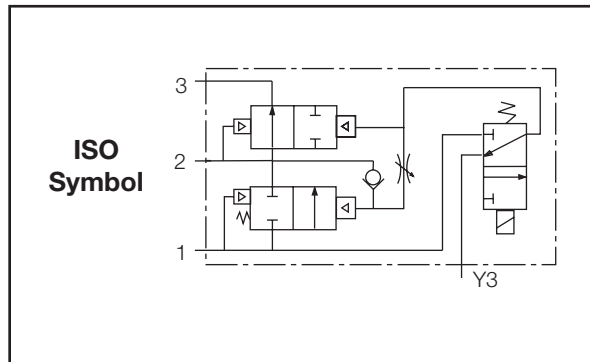
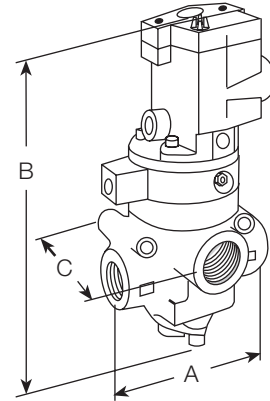

**ORDERING INFORMATION**

Select the port sizes in the sample model number below to specify the valve you want.

**V475 - A - 2 N4 W**

**VOLTAGE REQUIREMENT**

- 110/50Hz, 110-120/60Hz (AC)..... Leave Blank
- 12/50-60Hz (AC) ..... -A
- 24/50-60Hz (AC) ..... -B
- 48/50-60Hz (AC) ..... -C
- 220/50, 220-240/60Hz (AC) ..... -D
- 12v (DC) ..... -E
- 24v (DC) ..... -F
- 48v (DC) ..... -G
- 120v (DC) ..... -H

**INLET/OUTLET PORTS**

- 1/4 NPTF.....2
- 3/8 NPTF.....3
- 1/2 NPTF.....4
- 3/4 NPTF.....6
- 1 NPTF.....8

**PORT TYPE**

- NPTF Threads ..... Leave Blank
- BSPP threads ..... W

**EXHAUST PORT SIZE:**

- 1/2" exhaust port.....N4  
for 1/4, 3/8, 1/2 inlet / outlet ports
- 1" exhaust port.....N8  
for 1/2, 3/4, 1 inlet / outlet ports

# VANGUARD 2/2 Valves with Delayed-Pressure-Buildup Function V495 Models Port Sizes: 1/4 to 1-1/2

Model Shown: V495-2



- ◆ Delayed pressure buildup (DPB); rate of pressure buildup adjustable.
- ◆ 2-Way poppet valve. Available in three body sizes and seven port sizes.
- ◆ Use in conjunction with a lockout valve to provide an exhaust port as well as the lockout function.
- ◆ NPTF port threads; optional BSPP threads.

## VALVE OPERATION

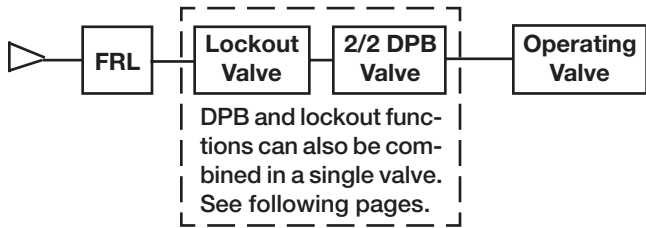

The lockout valve in the sketch above provides an exhaust port for exhausting downstream air when pressure is removed from the inlet of the 2/2 DPB valve.

## SPECIFICATIONS

**Ambient/Media Temperature:**

40° to 175°F (4° to 80°C).

**Fluid Media:** Compressed air.

**Inlet Pressure:** 30 to 150 psig (2 to 10 bar).

When air pressure is first applied to the inlet, air flow to the piston is restricted by the adjusting needle. Downstream air pressure gradually builds up at a rate determined by the setting of the adjusting needle.

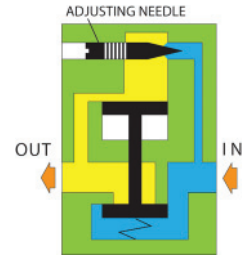

When downstream air pressure reaches the range of 40% to 60% of inlet pressure, the valve element shifts to the full open position and there is full air flow to the downstream components. This condition continues as long as there is air pressure at the inlet.

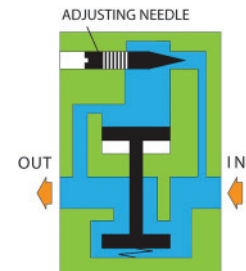

When inlet pressure is removed, the exhausting downstream air pressure keeps the inlet poppet open until the downstream pressure drops by approximately 90 percent. The remaining pressure is exhausted via the delay orifice. An upstream exhaust port (as in a separate lockout valve) is needed for proper operation.

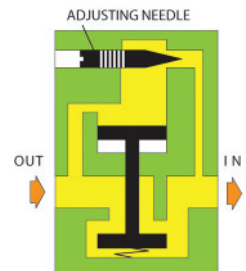



**DIMENSIONS** inches (mm)

Port Size	Average	A	B	C
	$C_v$			
1/4	2.3			
3/8	3.8	4.3 (108)	3.9 (99)	3.1 (79)
1/24.0				
1/2	7.7			
3/4	9.0	4.7 (119)	4.6 (116)	3.1 (79)
1 9.0				
1	24			
1-1/4	29	5.7 (146)	7.6 (193)	6.0 (153)
1-1/2	29			

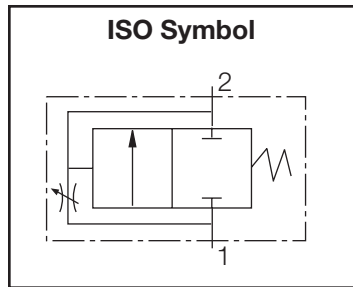
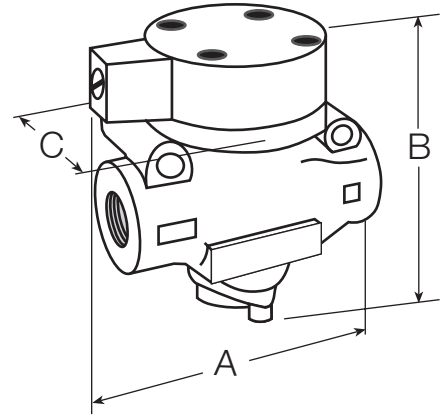

**ORDERING INFORMATION**

Select the port size in the sample model number below to specify the valve you want.

**V495 - 2 W**

**INLET/OUTLET PORTS**

- 1/4 NPTF ( $C_v = 2.3$ ).....V495-2
- 3/8 NPTF ( $C_v = 3.8$ ).....V495-3
- 1/2 NPTF ( $C_v = 4.0$ ).....V495-4
- 1/2 NPTF ( $C_v = 7.7$ )..... V495M-4
- 3/4 NPTF ( $C_v = 9.0$ ).....V495-6
- 1 NPTF ( $C_v = 9.0$ ).....V495-8
- 1 NPTF ( $C_v = 24$ )..... V495M-8
- 1-1/4 NPTF ( $C_v = 29$ ) .....V495-10
- 1-1/2 NPTF ( $C_v = 29$ ) .....V495-12

**PORT TYPE**

- NPTF Threads ..... Leave Blank
- BSPP threads ..... W

# Manual Control Consolidated Lockout and DPB Valves

# V45M Models Port Sizes: 3/8, 1/2, 3/4

Model Shown: V45M-6N6



## SPECIFICATIONS

**Ambient/Media Temperature:**

40° to 175°F (4° to 80°C).

**Fluid Media:** Compressed air.

**Inlet Pressure:** 30 to 150 psig (2 to 10 bar).



Valve Padlocked in Closed Position

- ◆ 3-Way spool lockout valve with added delayed pressure buildup function.
- ◆ Large operating handle is blue so it will be easily seen in the workplace.
- ◆ Manual lockout control; valve can be padlocked only in the closed position.
- ◆ Adjustable rate of delayed pressure buildup.
- ◆ Spool moves smoothly even after a long period on standby.
- ◆ Threaded exhaust port to accommodate a silencer or a line for remote exhausting.
- ◆ NPTF port threads; optional BSPP threads.

## VALVE OPERATION

**Valve closed.** With the blue handle pushed inward, air pressure at the inlet is blocked. Pressurized air remaining downstream is exhausted through the exhaust port.

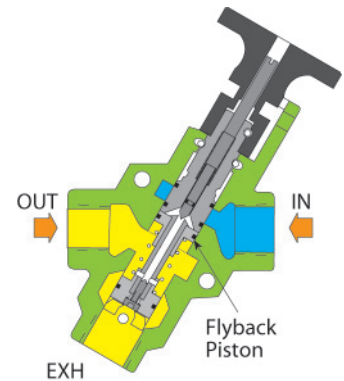

**Valve activated.** With the blue handle pulled outward, inlet air passes through the metered orifice (size set by adjusting screw) and begins to pressurize the outlet. High pressure inlet air on the top of the flyback piston prevents the spring behind it from sliding the piston along the spool. The position of the piston keeps the outlet blocked from the main flow of inlet air.

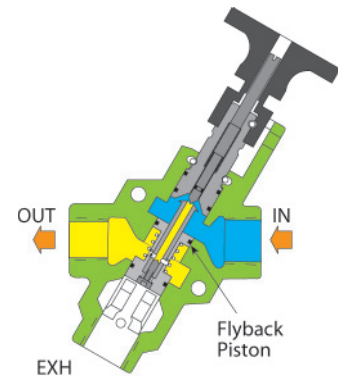

**Valve open.** Air through the metering orifice gradually increases the pressure on the spring side of the flyback piston. At about 25 psi less than inlet pressure the force on the piston is enough to slide it along the main spool. Inlet air then flows freely to the outlet.

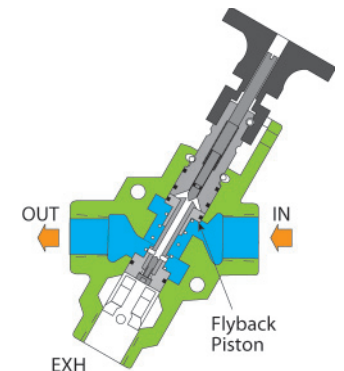

**DIMENSIONS** inches (mm)

Port Sizes		Average $c_v$		A	B	C
In-Out	Exh	1 to 2	2 to 3			
3/8	3/4	6.0	8.0			
1/2	3/4	7.1	8.3	6.4 (163)	8.8 (224)	2.0 (51)
3/4	3/4	8.6	9.5			

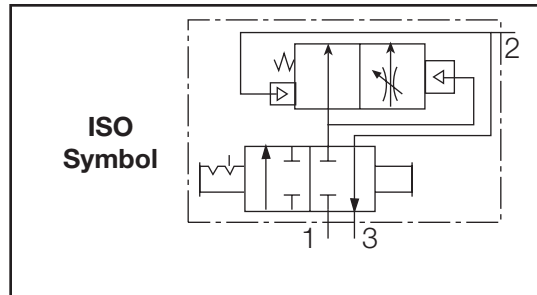
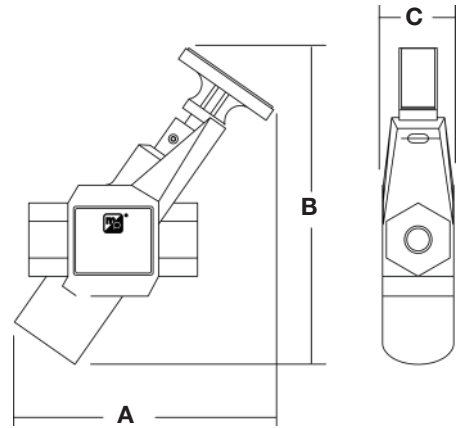

**ORDERING INFORMATION**

Select the port size in the sample model number below to specify the valve you want.

**V45M - 3 N6 W**

**INLET/OUTLET PORTS**

- 3/8 NPTF..... 3
- 1/2 NPTF..... 4
- 3/4 NPTF..... 6

**PORT TYPE**

- NPTF Threads ..... Leave Blank
- BSP threads ..... W

# Manual Control Consolidated Lockout and DPB Valves

# V380 Models Port Sizes: 3/8, 1/2, 3/4



Model Shown: V380-6

Patent No.: U.S. 6,893,002 B2

## SPECIFICATIONS

### Ambient/Media Temperature:

40° to 175°F (4° to 79°C).

**Body:** Die-cast zinc.

**Color:** Black body, yellow lockout sleeve.

**Fluid Media:** Compressed air.

**Elastomers:** Nitrile.

**Inlet Pressure:** 200 psig (13.8 bar) maximum.

**Ports:** Tapped inlet and outlet; untapped exhaust.

**Slide:** Acetal.

## VALVE OPERATION

**Slide Fully Extended:** Inlet pressure blocked; downstream air exhausted to atmosphere.

**Slide Inserted to Detent:** Inlet air allowed to build up downstream pressure gradually through a 0.050-inch orifice.

**Detent Button Pressed and Slide Fully Inserted:** Full pressure applied to downstream line.

- ◆ Modular or inline mounting.
- ◆ Provides positive lockout of supply air and exhausting of downstream air.
- ◆ Provides delayed pressure buildup for safe starts.
- ◆ 3-Port valve.
- ◆ Can be padlocked only in the closed position.
- ◆ NPTF port threads; optional SAE or BSPP threads.

## FLOW CHARTS

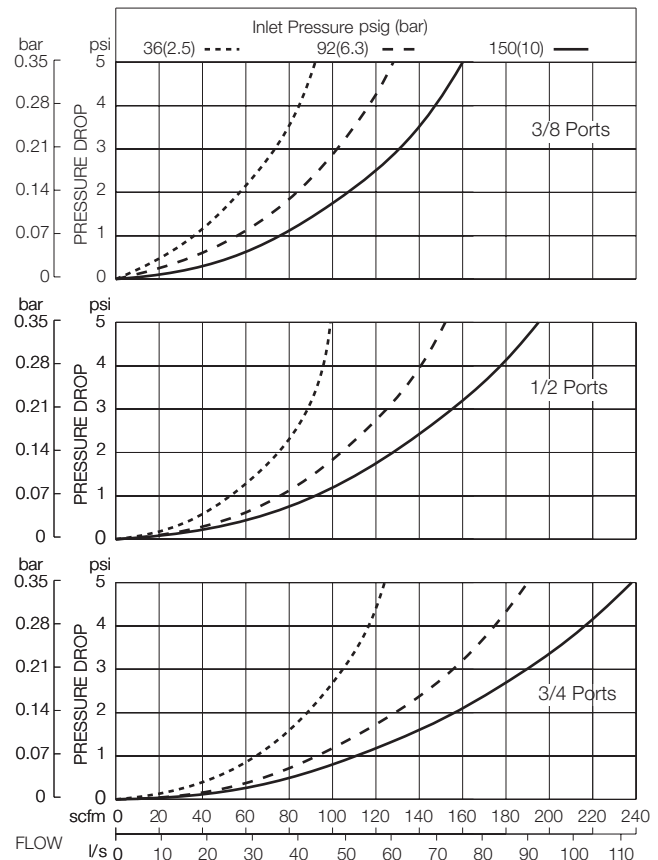

**DIMENSIONS** inches (mm)

Port Size	Average C <sub>v</sub>	A	B †	C	D
3/8	5.8				
1/2	7.0	2.3 (58)	2.6 (66)	0.9 (23)	2.9 (74)
3/4	8.6				

Dimension with valve closed; with valve open, 2.3 (58).

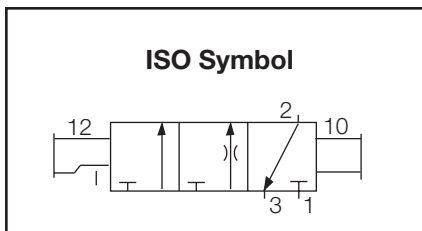
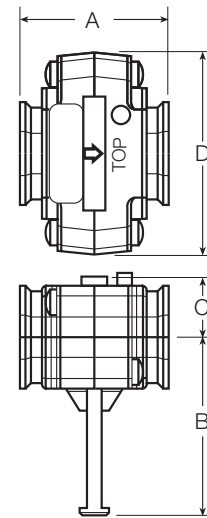

**ORDERING INFORMATION**

Select the port size in the sample model number below to specify the valve you want.

**V380 - 3 W**

**INLET/OUTLET PORTS**

- 3/8 NPTF..... 3
- 1/2 NPTF..... 4
- 3/4 NPTF..... 6
- 3/4-16 UNF SAE ..... S8
- 7/8-14 UNF SAE ..... S10

**PORT TYPE**

- NPTF Threads ..... Leave Blank
- BSP threads ..... W

# VANGUARD Remote Air Pilot 3/2 Valves with Lockout and DPB Functions

# V480 Models Port Sizes: 1/4 to 1

Model Shown: V480-8N8



- ◆ Manual lockout control; can be padlocked in the closed position.
- ◆ Delayed pressure buildup (DPB); rate of pressure buildup adjustable.
- ◆ 3-Way poppet valve. Available in two body sizes and five port sizes.
- ◆ Uses remote pilot control.
- ◆ Threaded exhaust port to accommodate a silencer or a line for remote exhausting.
- ◆ NPTF port threads; optional BSPP threads.

## SPECIFICATIONS

### Ambient/Media Temperature:

40° to 175°F (4° to 80°C).

**Fluid Media:** Compressed air.

**Inlet Pressure:** 15 to 150 psig (1 to 10 bar).

## VALVE OPERATION

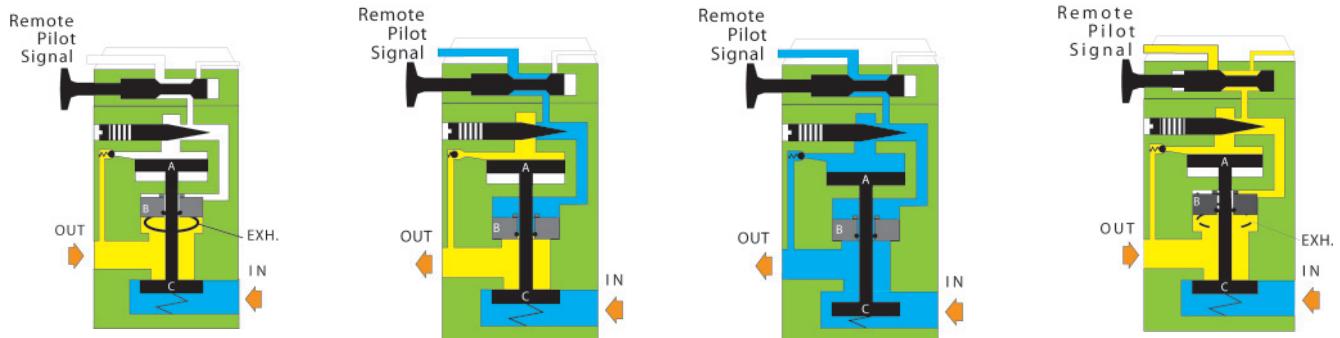

**Lockout open and no pilot signal.** Inlet air is blocked by inlet poppet C. Any downstream pressure forces sliding piston B upward. This opens the exhaust port and vents the downstream air.

**Lockout open and pilot signal applied.** Pilot air forces piston A downward to close exhaust port. Pilot air also flows past the metering pin, opens the ball check, and slowly pressurizes the outlet line. Pressure is also building up on piston A.

When the pressure on piston A reaches 50% of inlet pressure, the piston is forced downward, opening inlet poppet C. Inlet air now flows freely to the outlet port.

**Lockout closed.** At any time the lockout handle can be pushed inward, closing off the flow of pilot air. Pilot air above pistons A and B is then vented through the exhaust port. Piston A moves upward closing inlet poppet C. Sliding piston B moves upward opening the exhaust port and venting the downstream line.

**DIMENSIONS** inches (mm)

Port Sizes		Average $c_v$		A	B	C
In-Out	Exh	1 to 2	2 to 3			
1/4	1/2	2.5	3.1			
3/8	1/2	3.6	5.3	6.1 (153)	6.3 (161)	6.3 (161)
1/2	1/2	3.3	5.3			
1/2	1	6.3	9.2			
3/4	1	7.7	11	6.6 (167)	7.1 (180)	6.3 (161)
1	1	8.0	12			

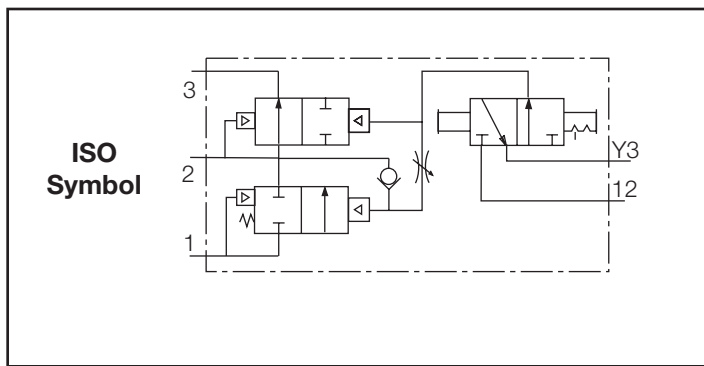
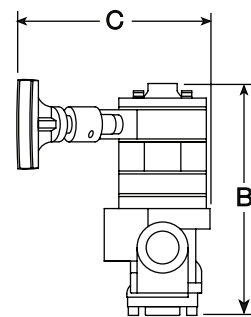
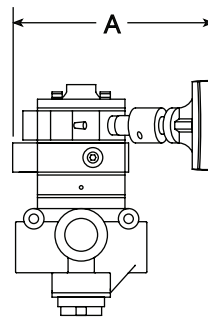

**ORDERING INFORMATION**

Select the port sizes in the sample model number below to specify the valve you want.

**V480 - 2 N4 W**

**INLET/OUTLETPORTS**

- 1/4 NPTF..... 2
- 3/8 NPTF..... 3
- 1/2 NPTF..... 4
- 3/4 NPTF..... 6
- 1 NPTF..... 8

**PORT TYPE**

- NPTF Threads ..... Leave Blank
- BSPP threads ..... W

**EXHAUST PORT SIZE:**

- 1/2 exhaust port ..... N4  
for 1/4, 3/8, 1/2 inlet / outlet ports.
- 1 exhaust port ..... N8  
for 1/2, 3/4, 1 inlet / outlet ports.

# VANGUARD Solenoid Pilot 3/2 Valves with Lockout and DPB Functions

# V485 Models Port Sizes: 1/4 to 1

Model Shown: V485-4N4



- ◆ Manual lockout control; can be padlocked in the closed position.
- ◆ Delayed pressure buildup (DPB); rate of pressure buildup adjustable.
- ◆ 3-Way poppet valve. Available in two body sizes and five port sizes.
- ◆ Uses solenoid pilot control.
- ◆ Solenoids CSA approved.
- ◆ Threaded exhaust port to accommodate a silencer or a line for remote exhausting.
- ◆ NPTF port threads; optional BSPP threads.

## SPECIFICATIONS

### Ambient/Media Temperature:

40° to 175°F (4° to 80°C).

**Fluid Media:** Compressed air.

**Inlet Pressure:** 15 to 150 psig (1 to 10 bar).

**Solenoid Voltages:** 110 volts 50/60 Hz standard.

Optional available voltages shown on following page.

## VALVE OPERATION

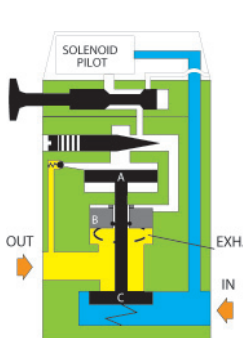

**Lockout open and pilot not energized.** Inlet air is blocked by inlet poppet C. Any downstream pressure forces sliding piston B upward. This opens the exhaust port and vents the downstream air.

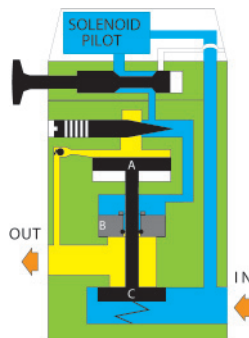

**Lockout open and pilot energized.** Pilot air forces piston B downward to close exhaust port. Pilot air also flows past piston A upward. This opens the metering pin, opens the ball check, and slowly pressurizes the outlet line. Pressure is also building up on piston A.

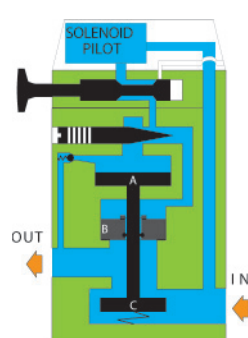

When the pressure on piston A reaches 50% of inlet pressure, the piston is forced downward, opening inlet poppet C. Inlet air now flows freely to the outlet port.

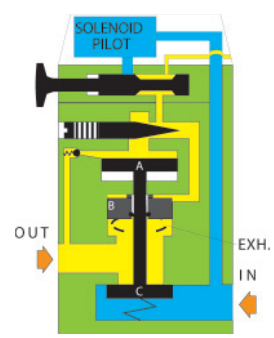

**Lockout closed.** At any time the lockout handle can be pushed inward, closing off the flow of pilot air. Pilot air above pistons A and B is then vented through the exhaust port. Piston A moves upward closing inlet poppet C. Sliding piston B moves upward opening the exhaust port and venting the downstream line.



**DIMENSIONS** inches (mm)

Port Sizes		Average $c_v$		A	B	C
In-Out	Exh	1 to 2	2 to 3			
1/4	1/2	2.5	3.1			
3/8	1/2	3.6	5.3	6.1 (153)	9.8 (249)	6.3 (161)
1/2	1/2	3.3	5.3			
1/2	1	6.3	9.2			
3/4	1	7.7	11	6.6 (167)	10.6 (268)	6.3 (161)
1	1	8.0	12			

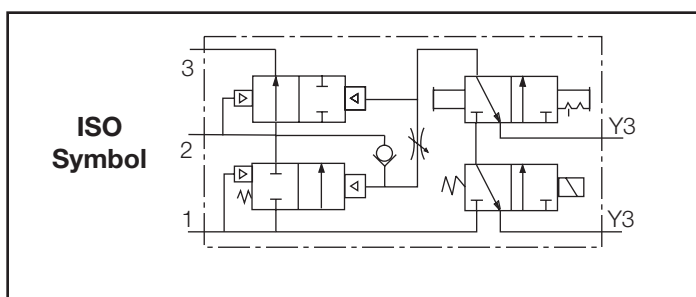
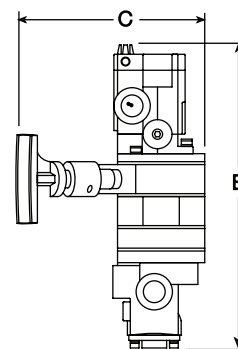
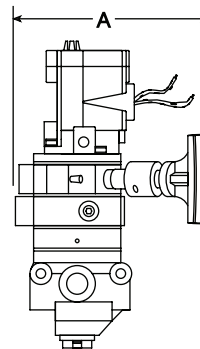

**ORDERING INFORMATION**

Select the port sizes in the sample model number below to specify the valve you want.

**V485 - A - 2 N4 W**

**VOLTAGE REQUIREMENT**

- 110/50Hz, 110-120/60Hz (AC)..... Leave Blank
- 12/50-60Hz (AC) ..... -A
- 24/50-60Hz (AC) ..... -B
- 48/50-60Hz (AC) ..... -C
- 220/50, 220-240/60Hz (AC) ..... -D
- 12v (DC) ..... -E
- 24v (DC) ..... -F
- 48v (DC) ..... -G
- 120v (DC) ..... -H

**INLET/OUTLET PORTS**

- 1/4 NPTF.....2
- 3/8 NPTF.....3
- 1/2 NPTF.....4
- 3/4 NPTF.....6
- 1 NPTF.....8

**PORT TYPE**

- NPTF Threads ..... Leave Blank
- BSPP threads ..... W

**EXHAUST PORT SIZE:**

- 1/2" exhaust port.....N4  
for 1/4, 3/8, 1/2 inlet / outlet ports.
- 1" exhaust port.....N8  
for 1/2, 3/4, 1 inlet / outlet ports

# AUXILIARY EQUIPMENT

Auxiliary valves are those used in pneumatic circuits to make the major components of the circuit work with greater versatility and efficiency. An example of the use of auxiliary valves is shown in the simple pneumatic circuit below.

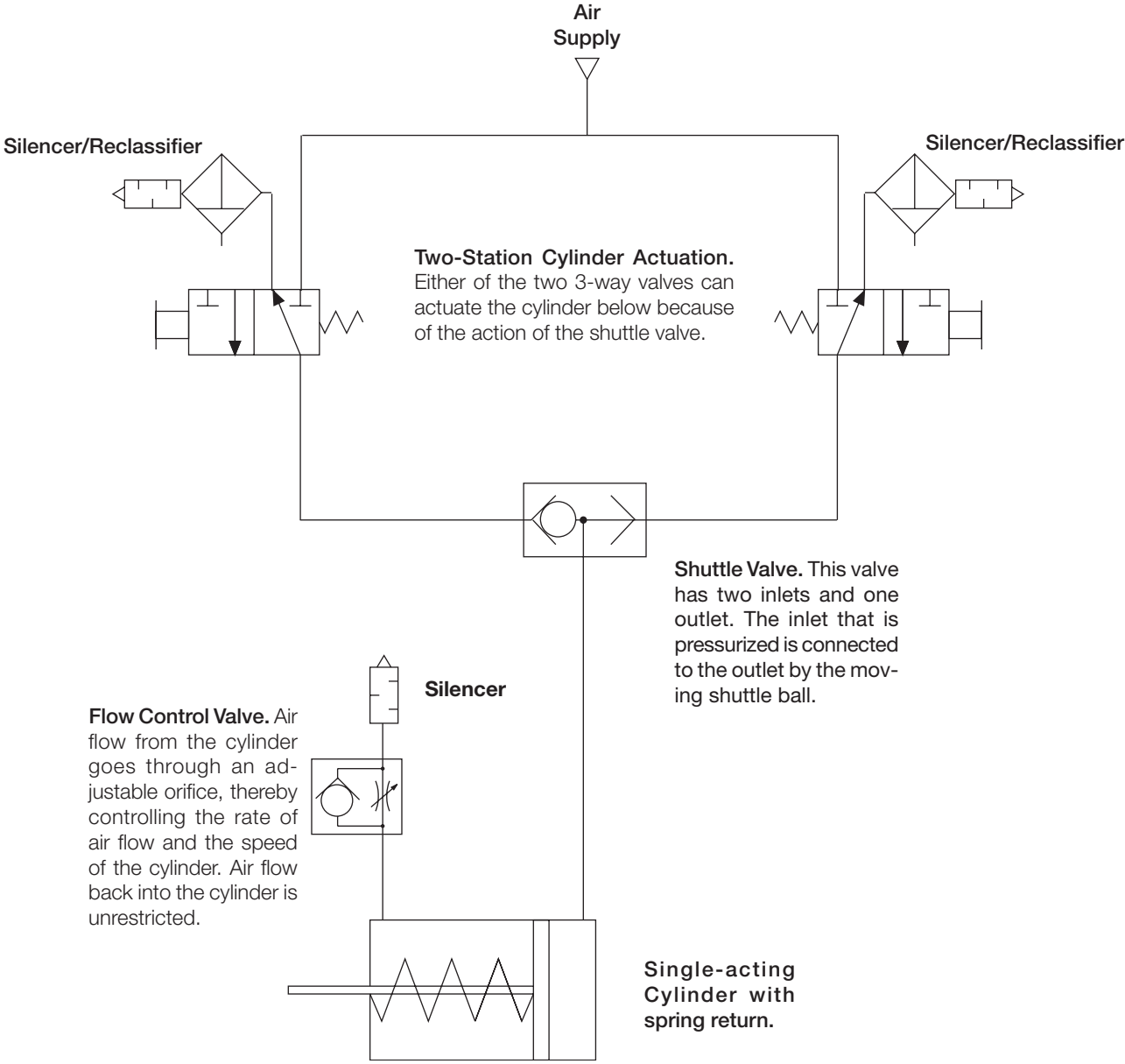



## FLOW CONTROL VALVES

Flow control valves have an adjustable orifice which restricts the flow of air in one direction through the valve. Free, unrestricted flow is allowed in the opposite direction. The restricted flow can be used at the outlet of a cylinder, for example, (see diagram on the facing page) to control the speed with which the cylinder's piston can move. Air returning to the cylinder is unrestricted. In such an application a flow control valve is sometimes called a speed control valve. For versatility in installation flow control valves are available for straight-through flow (V55 models) or for right-angle flow (V50 models).



## SHUTTLE VALVES

Shuttle valves have two inlet ports, but only one outlet port. The inlet port with the higher pressure is automatically connected to the outlet port. This allows an output signal to be initiated from two different locations. See circuit on the facing page.

SV20 shuttle valves are available with either 1/8 or 1/4 ports.

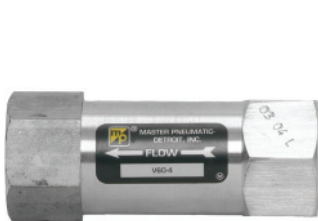

## CHECK VALVES

Check valves are flow actuated. They are used to allow air flow in one direction only, and to prevent flow in the opposite direction. V60 check valves are available with ports from 1/8 to 1.

# Shuttle Valves

## SV20 Models Port Size: 1/8, 1/4

Model Shown: SV20-2



- ◆ Valve has two inlets and one outlet. Valve is pressure actuated so that the inlet with the higher pressure is connected to the outlet.
- ◆ Nitrile or Teflon seals. Teflon seals are resistant to xylene and mek (*methyl ethylketone*).
- ◆ NPTF port threads; optional BSPP threads.

### SPECIFICATIONS

**Ambient/Media Temperature:**

40° to 175°F (4° to 79°C).

**Body:** Aluminum.

**Fluid Media:** Compressed air.

**Inlet Pressure:**

5 to 150 psig (0.3 to 10 bar) maximum.

**Seals:** Nitrile or Teflon.

## DIMENSIONS inches (mm)

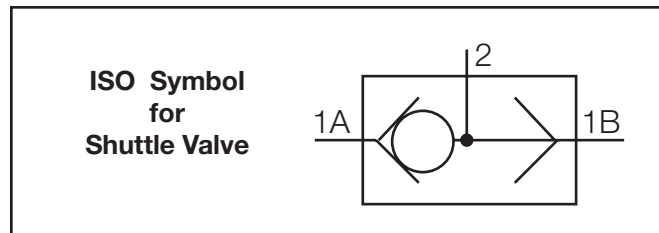
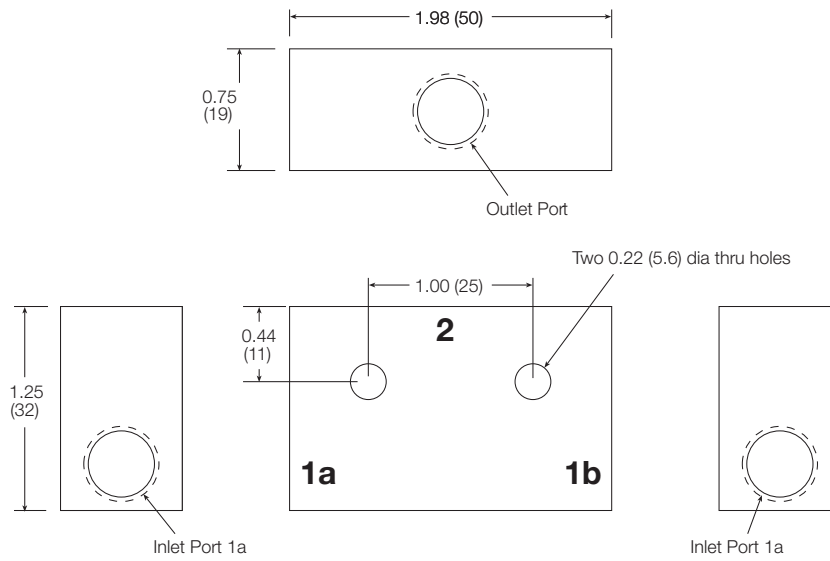

## ORDERING INFORMATION

Select the port sizes in the sample model number below to specify the valve you want.

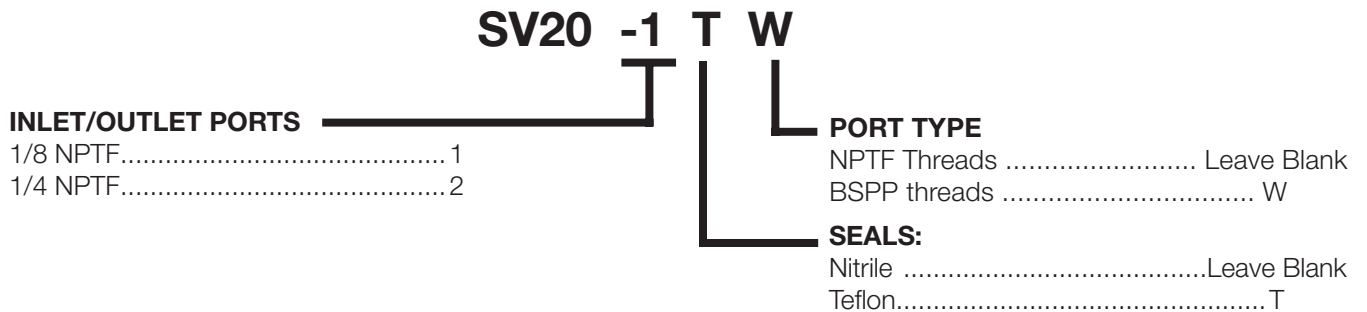

# Right-Angle Flow Control Valves

## V50 Models Port Size: 1/8 to 1/2 and Tube Fittings

Model Shown: V50-4



- ◆ Screws directly into a cylinder port.
- ◆ Inlet port swivels for optimum placement.
- ◆ Models available with either knurled-knob adjustment or screwdriver-slot adjustment.
- ◆ Four body sizes.
- ◆ **NPTF** port threads; optional **BSPP** threads. Also push-on tube fittings.

### SPECIFICATIONS

**Ambient/Media Temperature:**

40° to 175°F (4° to 79°C).

**Flow Adjustment:** Knurled knob or screwdriver slot.

**Fluid Media:** Compressed air.

**Inlet Pressure:**

5 to 150 psig (0.3 to 10 bar) maximum.

TYPICAL PERFORMANCE CURVE

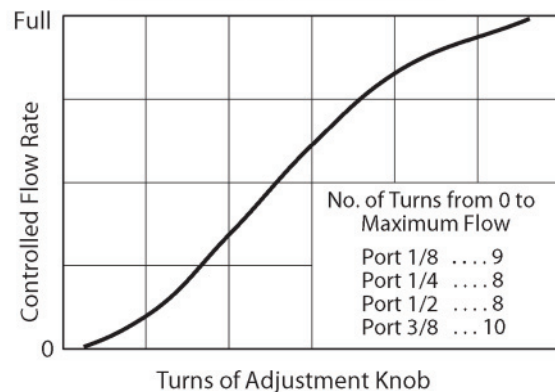

## DIMENSIONS inches (mm)

Port or Tube OD Size	Average $C_v$ (Full Flow)	Type of Adjustment	A	B	C
1/8	0.3	Slot	1.0 (25)	1.4 (36)	0.63 (16)
		Knob	1.0 (25)	1.9 (48)	0.63 (16)
1/4	0.6	Slot	1.3 (33)	1.6 (41)	0.79 (20)
		Knob	1.0 (25)	2.2 (56)	0.63 (16)
3/8	1.9	Slot	1.5 (38)	2.2 (56)	0.94 (24)
		Knob	1.5 (38)	3.0 (77)	0.94 (24)
1/2	2.8	Slot	1.9 (47)	2.7 (68)	1.2 (30)
		Knob	1.9 (47)	3.7 (93)	1.2 (30)

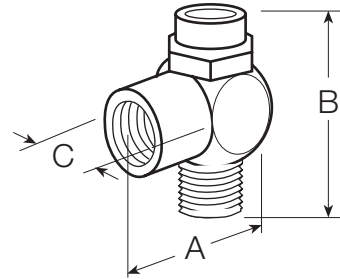

Flow adjustment by screw-driver slot or knurled knob (dotted line).

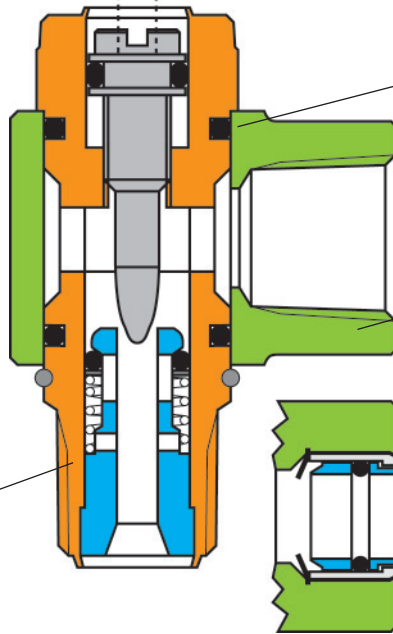

O-ring seals on adjusting stem provide friction to keep stem in its set position.

Inlet is a swivel port which rotates 360° for optimum placement.

Threads are coated with pipe sealant. Screw directly into cylinder port.

Removable tubing release ring.

### ORDERING INFORMATION

Order by the model number given below.

For **BSPP** port threads add **W** to the end of the model number.

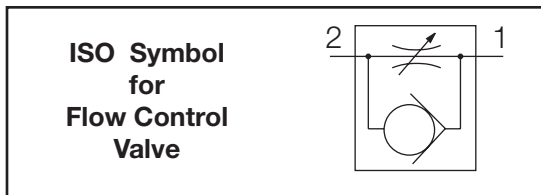

Port or Tube OD Size	Average $C_v$ (Full Flow)	Type of Adjustment	Model Numbers	
			Threaded Inlet	Tube Fitting
1/8	0.3	Slot	V50S-1	V50S-02
		Knob	V50-1	V50-02
1/4	0.6	Slot	V50S-2	V50S-04
		Knob	V50-2	V50-04
3/8	1.9	Slot	V50S-3	V50S-06
		Knob	V50-3	V50-06
1/2	2.8	Slot	V50S-4	—
		Knob	V50-4	—

# Inline Flow Control Valves

## V55 Models Port Size: 1/4 to 1-1/4



Model Shown: V55-6

- ◆ Straight-through design provides high air flow into a cylinder.
- ◆ Flow out of a cylinder can be precisely controlled. Adjustable flow can range from near zero to full flow.
- ◆ Adjustment control can be locked in position to prevent a change due to vibration.
- ◆ Three body sizes.
- ◆ NPTF port threads; optional BSPP threads.

### SPECIFICATIONS

**Ambient/Media Temperature:**

40° to 175°F (4° to 79°C).

**Body:** Aluminum with brass adjusting stem.

**Fluid Media:** Compressed air.

**Inlet Pressure:**

5 to 150 psig (0.3 to 10 bar) maximum.

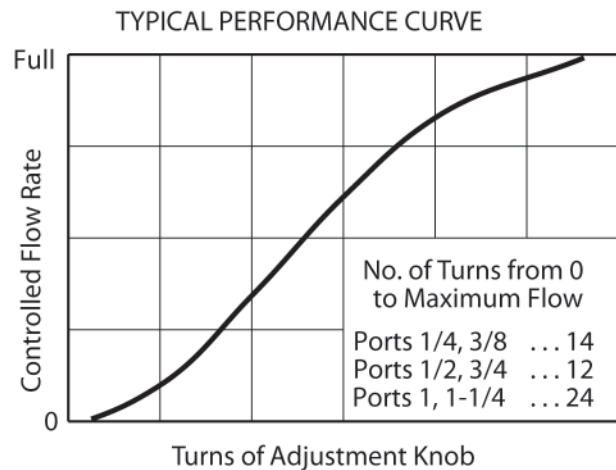



**DIMENSIONS** inches (mm)

Port Size	Average $C_v$ (Full Flow)	A	B	C
1/4	2.3	2.8	1.3	2.5
3/8	2.6	(70)	(32)	(64)
1/2	7.5	3.8	1.6	3.1
3/4	8.3	(95)	(40)	(78)
1	17	5.0	2.5	4.4
1-1/4	22	(127)	(64)	(111)

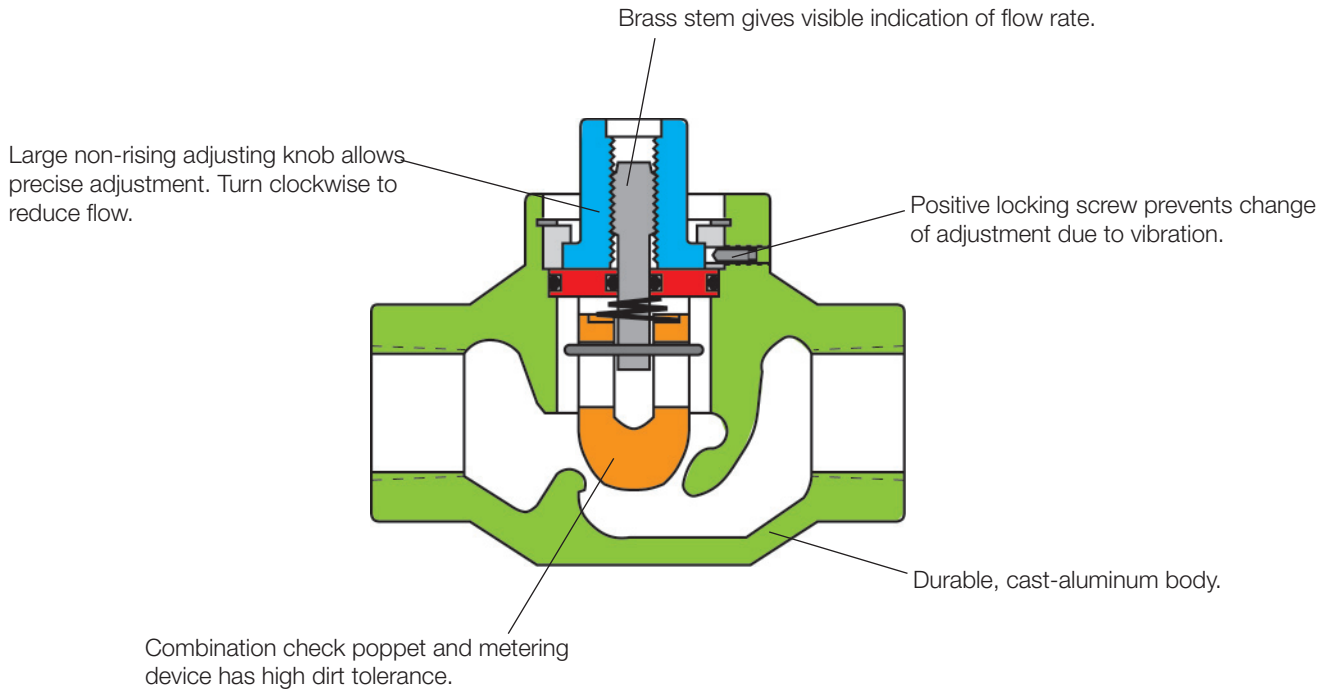
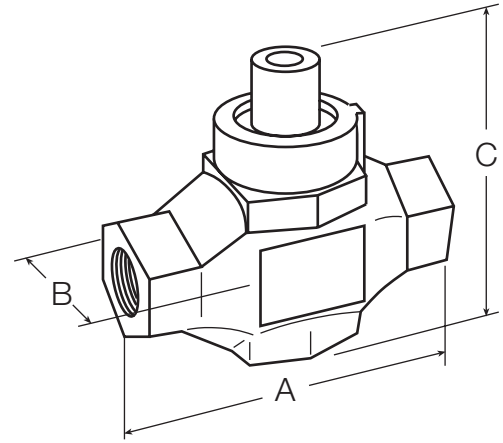

**AUXILIARY EQUIPMENT**

**ORDERING INFORMATION**

Order by the model number given below.  
For BSPP port threads add W to the end of the model number.

Port Size	Average $C_v$ (Full Flow)	Model Number
1/4	2.3	V55-2
3/8	2.6	V55-3
1/2	7.5	V55-4
3/4	8.3	V55-6
1	17	V55-8
1-1/4	22	V55-10

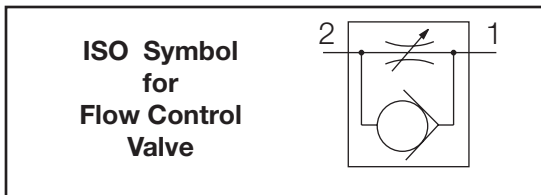

# Check Valves

## V60 Models Port Size: 1/8 to 1

Model Shown: V60-4



- ◆ Flow-actuated so that they allow full air flow in one direction, but are fully closed to air flow in the opposite direction.
- ◆ Self-cleaning poppet design tolerates dirty air.
- ◆ NPTF port threads; optional BSPP threads.

Model Shown: V60-8



### SPECIFICATIONS

**Ambient/Media Temperature:**

40° to 175°F (4° to 79°C).

**Fluid Media:** Compressed air.

**Inlet Pressure:**

5 to 150 psig (0.3 to 10 bar) maximum.

**Cracking Pressure:** Less than 1.5 psi (0.1 bar).

DIMENSIONS inches (mm)

Valve Style	Port Size	Average $C_v$	A	B	C	Weight lb (kg)
X	1/8	0.5	2.71	.2	1.0	0.5
	1/4	0.5	(69)	(30)	(25)	(0.23)
Y	1/4	2.9	2.8 (71)	1.6 (40)	1.4 (35)	0.5 (0.23)
	3/8	3.7	2.8 (71)	1.6 (40)	1.4 (35)	
	1/2	3.9	3.7 (94)	1.6 (40)	1.4 (35)	
Z	3/4	8.6	8.6	4.8	1.8	3.2 0.9
	1	8.3	(122)	(46)	(81)	(0.41)

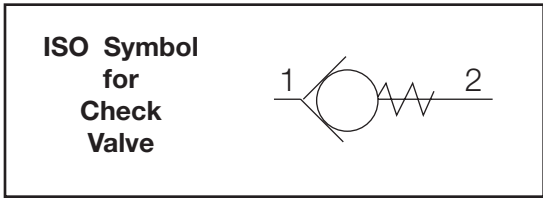
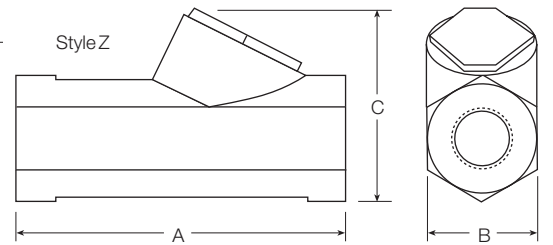
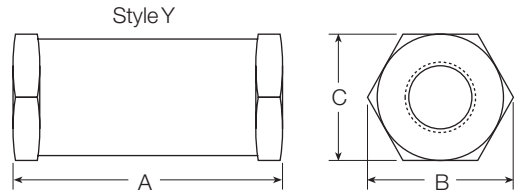
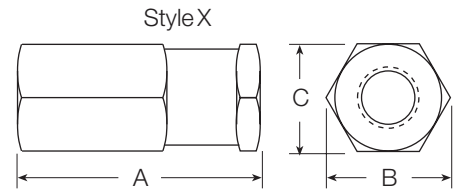

**AUXILIARY EQUIPMENT**

**ORDERING INFORMATION**

Order by the model number given in the chart below.  
 For **BSPP** port threads add W to the end of the model number.

Valve Style	Port Size	Average $C_v$	Model Number
X	1/8	0.5	V60-1
	1/4	0.5	V60-2
Y	1/4	2.9	V60M-2
	3/8	3.7	V60-3
	1/2	3.9	V60-4
		5.2	V60M-4
Z	3/4	8.6	V60-6
	1	8.3	V60-8
	1	17	V60M-8

# GENERAL PURPOSE FILTERS

## FILTER FUNCTION

General purpose compressed air filters remove water and particulate material from the air stream to protect downstream equipment from contamination. As air enters the filter, internal baffles create a swirling motion to the air so that entrained dirt and liquids are thrown against the sides of the filter bowl and then fall to the sump area at the bottom of the bowl.

Additional baffling keeps the air in the sump area relatively quiet; this ensures that the removed material is not returned to the air flow going to the filter element. The filter element will then collect smaller particles.

The most frequently used element in Master Pneumatic general purpose filters is rated at 5  $\mu\text{m}$ , so that nearly all

particles larger than 5  $\mu\text{m}$  (*half the diameter of a human hair*) will be collected in the filter element.

## FILTER SELECTION

General purpose filter elements are available with 5- $\mu\text{m}$  and 40- $\mu\text{m}$  ratings; some units can also be provided with 20- $\mu\text{m}$ -rated elements. The most efficient filter element is one selected by taking into consideration the dirtiness of the ambient air and the needed cleanliness of the air after filtration.

Some high-capacity filters have 40- $\mu\text{m}$  elements which are satisfactory for general piping. At point of use, and with smaller filters, the standard 5- $\mu\text{m}$  element is most commonly used and recommended. See coalescing filters for finer filtration.

## GUIDE to GENERAL PURPOSE FILTERS

Filter Series	Modular Construction	Port Sizes										Pages
		1/8	1/4	3/8	1/2	3/4	1	1-1/4	1-1/2	2		
<b>SENTRY</b>												
FD10 models †	yes	X	X									48-49
<b>MINIATURE</b>												
FD50 models	no	X	X									50-51
F50S stainless steel models	no		X									52-53
<b>GUARDSMAN</b>												
FD60 models	yes		X	X	X							54-55
<b>GUARDSMAN II</b>												
BFD70 models	yes		X	X	X							56-57
<b>Full-Size VANGUARD</b>												
FD100 models	yes		X	X	X	X						58-59
<b>Full-Size SERIES 380</b>												
FD380 models	yes			X	X	X						60-61
<b>High-Capacity VANGUARD</b>												
FD100, BFD100 models	no					X	X	X	X	X		62-65
BFD200 models	no					X	X	X	X			66-69

† Also available with quick-connect tube fittings up to 10 mm.

## FILTER MAINTENANCE

Filters must be attended to on a regular basis in order to rid them of water and other contaminants. The use of an automatic drain is highly recommended because it greatly reduces the need for frequent individual attention. This is especially important if access to the filter is difficult, because difficult access makes it much more likely that regular maintenance will be overlooked. If a filter is equipped with a manual drain, accumulated water must be removed regularly so that it does not clog the filter.

Pressure drop across filter elements increases as they continue to remove dirt from the air. They should be inspected on a regular basis, and replaced to restore full efficiency.

Under average conditions filter elements should be replaced each year.

## CARE OF PLASTIC BOWLS

Plastic bowls are made of high-strength polycarbonate, a very tough transparent material. Bowls are intended for use with compressed air, but can be adversely affected if contaminants such as alcohol or liquified petroleum gas are in the intake air. Some compressor oils, solvent fumes, and other substances can attack the bowl and lead to failure.

When a bowl is cleaned (by wiping inside and outside with a clean dry cloth) it should be inspected for cracks or scarring on the surface. If either condition occurs it is an indication that the ambient air contains harmful substances, and the bowl should be replaced, preferably with

a metal bowl.

Just a few of the substances that can harm polycarbonate bowls are: acetone, ammonia, benzene, brake fluids, carbon disulfide, carbon tetrachloride, ethyl acetate, ethylene glycol, Freon, lacquer thinner, nitrocellulose lacquer, sodium hydroxide, toluene, turpentine, and many others.

Small bowls (i.e., Sentry and Miniature bowls) do not need bowl guards. However, metal shatterguards are supplied with larger bowls and must always be used.

Never use polycarbonate bowls at temperatures above 125°F (52°C) or pressures above 150 psig (10 bar). For conditions exceeding these limits use metal bowls.

## BOWL DRAINS

Manual drains are the simplest bowl drains, but they require frequent attention to rid the bowl of accumulated water and dirt particles. If a filter is located where it is difficult to access, it might not be drained as often as it should be. For this reason, and to save a lot of maintenance manpower, automatic drains (see next page) are standard equipment and provide a cost-effective way to maximize filter performance and reduce maintenance.

Tube-Away kits (see **ACCESSORIES**) supply tubing for **VANGUARD** filters with automatic drains to carry water and dirt to a suitable drainage outlet.

**HYDRO-JECTOR** external drains (see next page) for **SERIES 380** and **VANGUARD** filters are for use wherever severe condensate problems exist. They operate automatically whenever liquid in the bowl raises the float activating the drain.

The **WARRIOR** drain (see **ACCESSORIES**) is electronically controlled, and allows filter draining to occur at specific intervals and for specific lengths of time.

### IMPORTANT NOTE

Before inspecting or servicing a filter (or any other pneumatic component) be sure that the pneumatic pressure to the component is shut off and exhausted, and cannot be inadvertently turned on.

## INTERNAL AUTOMATIC DRAIN

Manual draining is often inconvenient, and overlooked. Manual drains require frequent attention to rid the bowl of accumulated water and dirt particles. If a filter is located where it is difficult to access, it might not be drained as often as it should be. Automatic drains are standard on Master Pneumatic filters and we strongly recommend their use to improve filter effectiveness, lengthen service life, and reduce maintenance needs.

The Master Pneumatic automatic drain operates when liquids have accumulated in the filter bowl and a pressure drop of 2 psi or more occurs (e.g., when a valve or other device is actuated). The pressure drop triggers the automatic drain to expel accumulated liquid. The drain activates whenever the air supply is shut down and exhausted. An adjusting knob at the bottom of the filter can be set for optimum performance with very high or low flows of air.

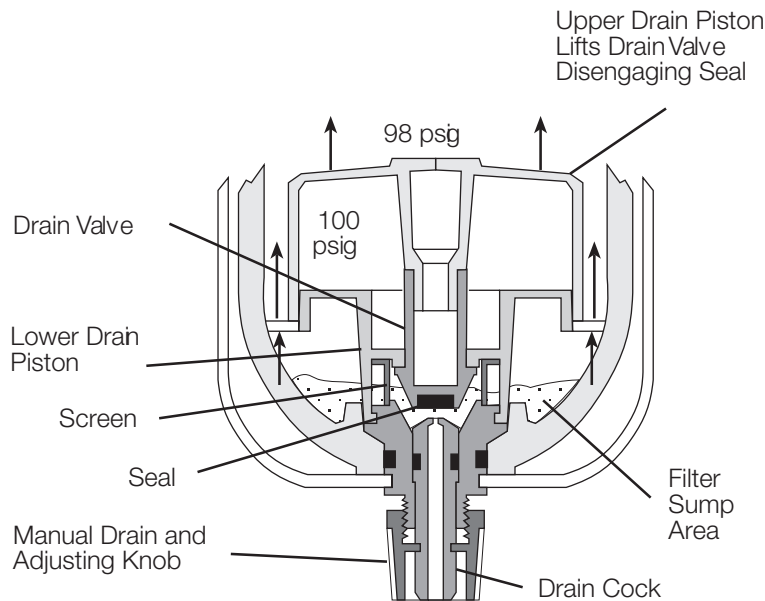

**Vanguard Internal Automatic Bowl Drain**

## HYDRO-JECTOR EXTERNAL DRAINS

**HYDRO-JECTOR** drains are for use with the **SERIES 380** and **VANGUARD** filters wherever severe condensate problems exist. They can also be used to drain water separators, drain legs, and compressor receiver tanks. They operate with continuous, intermittent, or no air flow, and drain only when liquids are present.

Discharge rate is 300 gallons (1135 liters) per hour at 100 psig (6.9 bar). Flushing action is instantaneous with no air loss. There is a manual override on the drain valve for clean-out and emer-

gency use. **HYDRO-JECTOR** drains are available with 1/8 or 1/4 nipples. The 1/4 size is used with **SERIES 380** and **VANGUARD** filters.

The **HYDRO-JECTOR** is not recommended where heavy oil or foam is present, as can be the case in separators or large after-coolers.

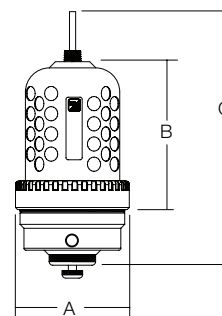

**Model Shown:** E100-2

Port Size	Unit Number Plastic Bowl *	Maximum Dimensions inches (mm)			Weight lb (kg)	
		A	B	C		
1/8	E100-1	3.5 (89)	4.2 (106)	8.3 (211)	3.5 (89)	2.6 (1.2)
1/4 †	E100-2	3.5 (89)	4.2 (106)	8.3 (211)	3.5 (89)	2.6 (1.2)

\* To order with a metal bowl precede the model number with a B, e.g., BE100-1.

† Used with LDC filter bowl option for **SERIES 380** and **VANGUARD** filters.

## A COST-EFFECTIVE SOLUTION TO THE REMOVAL OF WATER FROM A COMPRESSED AIR SYSTEM

Compressing ambient air to 100 psig creates air temperatures as high as 360°F (182°C) in the compressor cylinders. Typically, at this high temperature and with an air compressor rated at 450 scfm (210 l/s), the amount of water vapor generated will convert to 3.5 gallons (13 liters) of water for each hour of operation.

The hot air will be 100% saturated with water vapor, i.e., at its dew point. Even the smallest reduction in temperature will result in a “rain storm” within the compressed air system, and liquid water will accumulate. This water must be removed before it finds its way downstream where it can do considerable damage.

**VANGUARD** or **SERIES 380** heavy-duty filters paired with **HYDRO-JECTOR** drains provide a low-cost, and ef-

fective means for draining water from the system before it can do harm. Smaller plants, those with 100 to 500 scfm compressors, will find this an especially economical way to cope with the water problem.

**FILTER/HYDRO-JECTOR Installation:** The **VANGUARD** and **SERIES 380** filters must be ordered with the option designated “**LDC**”. This option removes the drain cock, and replaces it with a 1/4” threaded adapter. This will then receive the **HYDRO-JECTOR** drain which has a rubber spacer that goes between the filter and the drain.

See the sample compressor circuit below to see how the filter and **HYDRO-JECTOR** drains are used.

### TYPICAL COMPRESSOR CIRCUIT EMPLOYING HYDRO-JECTOR DRAINS

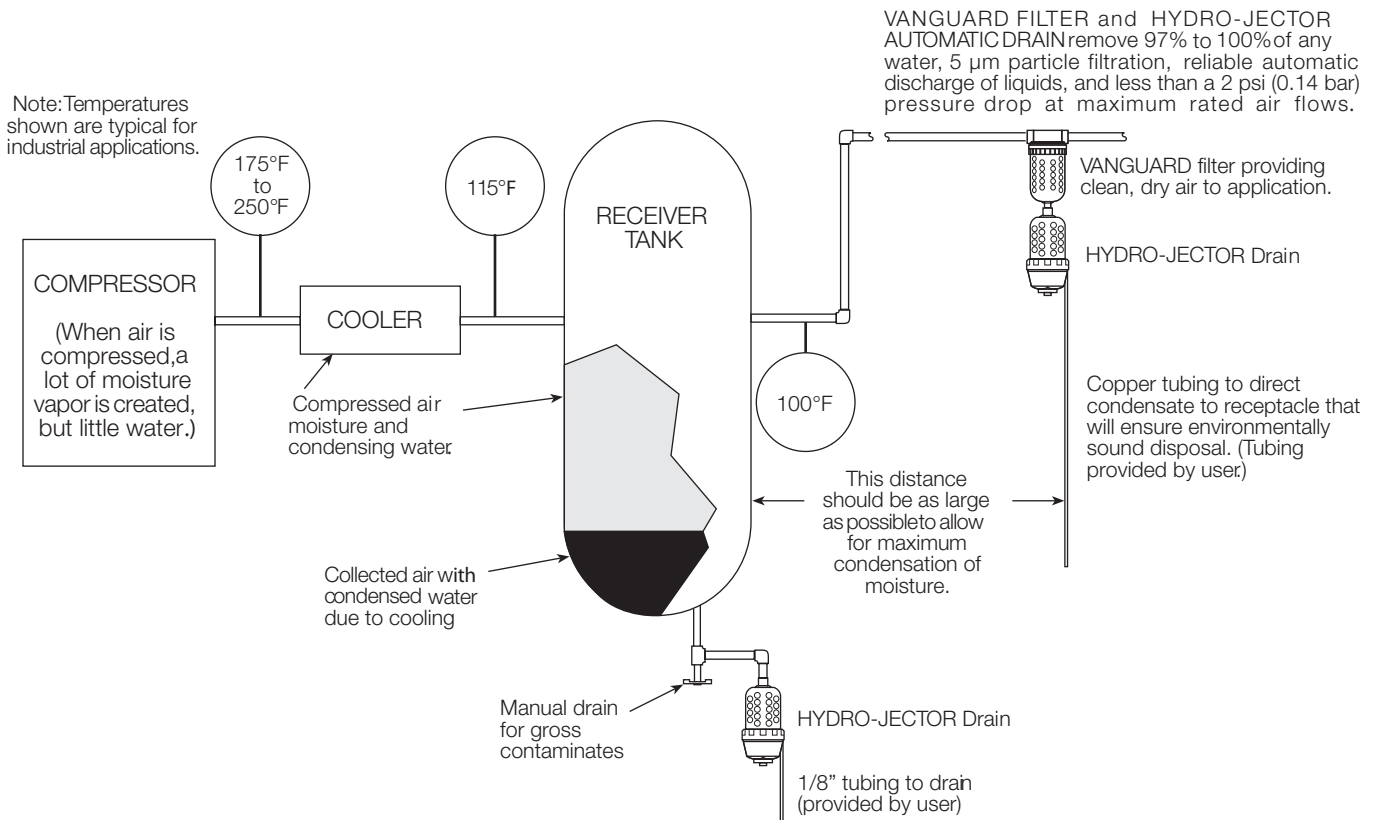

# SENTRY Modular General Purpose Filters

# FD10 Models Port Sizes: 1/8, 1/4; Tube Fittings



Model Shown: F10-2

- ◆ Modular assembly and mounting.
- ◆ Threaded ports or quick-connect fittings for tubing up to 10 mm in diameter.
- ◆ 5- $\mu$ m-rated polyethylene filter element; optional sintered bronze elements.
- ◆ High-strength polycarbonate plastic filter bowl; optional metal bowl.
- ◆ Internal automatic drain; optional manual drain.
- ◆ NPTF port threads; optional BSPP threads.

## SPECIFICATIONS

### Ambient/Media Temperature:

40° to 125°F (4° to 52°C).

### Body:

Acetal.

**Bowl:** 2-Ounce (60-ml) capacity polycarbonate plastic; optional aluminum bowl.

### Bowl Drain:

Internal automatic drain; optional manual drain.

**Filter Element:** 5- $\mu$ m-rated polyethylene; optional 5- $\mu$ m, 20- $\mu$ m, or 40- $\mu$ m sintered bronze.

**Fluid Media:** Compressed air.

### Inlet Pressure:

15 psig (1 bar) minimum with automatic drain.  
150 psig (10 bar) maximum.

**Seals:** Nitrile.

## FLOW CHART

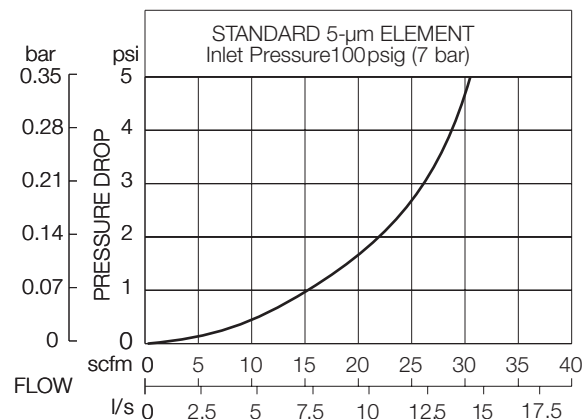



## DIMENSIONS inches (mm)

Ports	A	B †	C	Depth	Weight lb (kg)
No Port	1.7 (43)	3.6 (92)	0.5 (13)	1.8 (45)	0.27 (0.12)
1/8, 1/4	3.0 (76)	3.6 (92)	0.5 (13)	1.8 (45)	0.49 (0.22)
<b>Models below have quick-connect fittings for tubing.</b>					
1/4	3.4 (86)	3.6 (92)	0.5 (13)	1.8 (45)	0.47 (0.21)
3/8	3.9 (99)	3.6 (92)	0.5 (13)	1.8 (45)	0.47 (0.21)
4 mm	3.4 (86)	3.6 (92)	0.5 (13)	1.8 (45)	0.47 (0.21)
6 mm	3.4 (86)	3.6 (92)	0.5 (13)	1.8 (45)	0.47 (0.21)
8 mm	3.1 (79)	3.6 (92)	0.5 (13)	1.8 (45)	0.47 (0.21)
10 mm	3.9 (99)	3.6 (92)	0.5 (13)	1.8 (45)	0.47 (0.21)

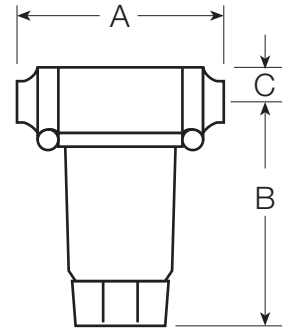

† Dimension for plastic bowl; metal bowl is 4.3 (109).

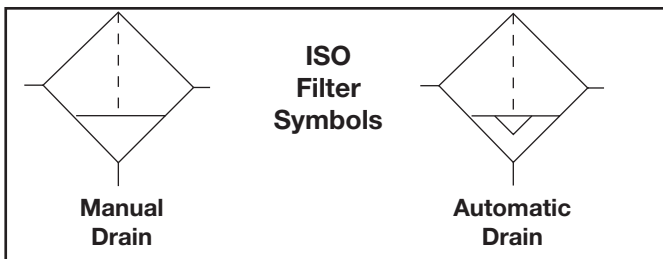

## REPLACEMENT FILTER ELEMENT KITS

Element Type	Kit Number
5-µm polyethylene (Std element).....	KA130-27PE5
5-µm bronze .....	KA130-27E5
20-µm bronze .....	KA130-27E4
40-µm bronze .....	KA130-27E3

## ORDERING INFORMATION

Change the letters in the sample model number below to specify the filter you want.

### B FD 10 P - 2 X Y W

#### BOWL TYPE

Plastic bowl..... Leave blank  
Metal bowl.....B

#### BOWL DRAIN

Internal automatic drain ..... FD  
Manual drain..... F

#### MOUNTING HOLE LOCATION

Bottom mount (Standard) ..... Leave Blank  
Top mount ..... P

#### INLET PORT SIZE

No Inlet and Outlet ports..... Leave Blank

#### Threaded:

1/8 NPTF .....-1  
1/4 NPTF .....-2

#### Fittings for Tubing:

1/4 .....-04  
3/8 .....-06  
4 mm .....-M4  
6 mm .....-M6  
8 mm .....-M8  
10 mm .....-M10

#### PORT TYPE

As specified in **INLET PORT**.... Leave Blank  
BSPP threads on both ports ..... W

#### OPTIONS

None ..... Leave Blank

#### Sintered bronze filter element:

5-µm rating ..... E5  
20-µm rating ..... E4  
40-µm rating ..... E3

#### OUTLET PORT SIZE

Same as inlet port ..... Leave Blank

#### Threaded:

1/8 NPTF ..... 1  
1/4 NPTF ..... 2

#### Fittings for Tubing:

1/4 ..... 04  
3/8 ..... 06  
4 mm ..... M4  
6 mm ..... M6  
8 mm ..... M8  
10 mm ..... M10

# MINIATURE General Purpose Filters

# FD50 Models Port Sizes: 1/8, 1/4



Model Shown: F50-1

- ◆ Inline mounting.
- ◆ 5- $\mu$ m-rated polyethylene filter element; optional sintered bronze elements.
- ◆ High-strength polycarbonate plastic filter bowl; optional metal bowl.
- ◆ Internal automatic drain; optional manual drain.
- ◆ NPTF port threads; optional BSPP threads.

## SPECIFICATIONS

### Ambient/Media Temperature:

Plastic bowl: 40° to 125°F (4° to 52°C).

Metal bowl: 40° to 150°F (4° to 66°C).

**Body:** Aluminum.

**Bowl:** 2-Ounce (60-ml) capacity polycarbonate plastic; optional aluminum bowl.

### Bowl Drain:

Internal automatic drain; optional manual drain.

**Filter Element:** 5- $\mu$ m-rated polyethylene; optional 5- $\mu$ m, 20- $\mu$ m, or 40- $\mu$ m sintered bronze.

**Fluid Media:** Compressed air.

### Inlet Pressure:

15 psig (1 bar) minimum with automatic drain.

Plastic bowl: 150 psig (10 bar) maximum.

Metal bowl: 200 psig (14 bar) maximum.

**Seals:** Nitrile.

## FLOW CHART

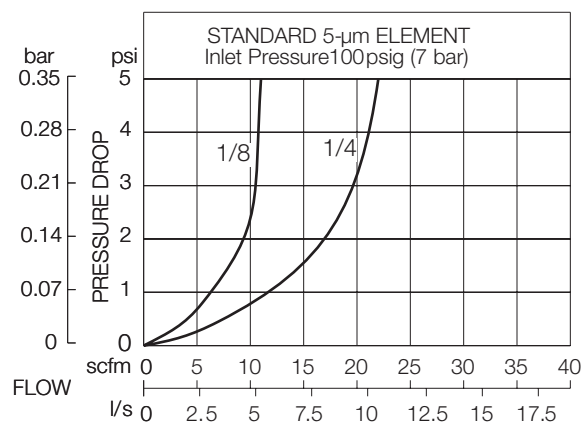

**DIMENSIONS** inches (mm)

Bowl	Ports	A	B	C	Depth	Weight
						lb (kg)
Plastic	1/8, 1/4	1.6 (41)	3.6 (92)	0.4 (9.5)	1.6 (41)	0.33 (0.15)
Metal	1/8, 1/4	1.6 (41)	4.3 (109)	0.4 (9.5)	1.6 (41)	0.35 (0.16)

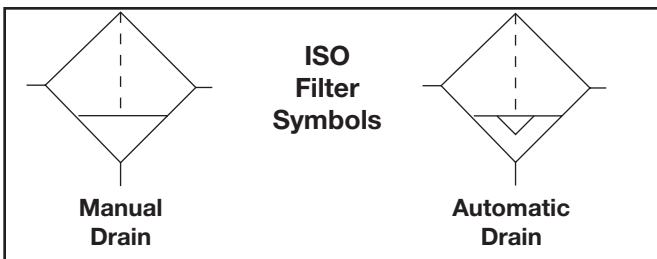
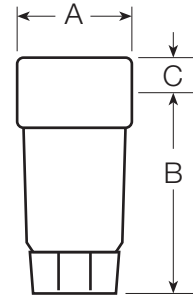

**REPLACEMENT FILTER ELEMENT KITS**

Element Type	Kit Number
5-µm polyethylene (Std element).....	KA130-27PE5
5-µm bronze .....	KA130-27E5
20-µm bronze .....	KA130-27E4
40-µm bronze .....	KA130-27E3

**ORDERING INFORMATION**

Change the letters in the sample model number below to specify the filter you want.

**B FD 50 - 2 Y W**

**BOWL TYPE**

Plastic bowl ..... Leave blank  
Metal bowl..... B

**BOWL DRAIN**

Internal automatic drain ..... FD  
Manual drain..... F

**PORT SIZE**

1/8 NPTF..... 1  
1/4 NPTF..... 2

**PORT TYPE**

NPTF Threads ..... Leave Blank  
BSPP threads ..... W

**OPTIONS:** *(More than one option can be chosen)*

None ..... Leave Blank

**Sintered bronze filter element:**

5-µm rating ..... E5  
20-µm rating ..... E4  
40-µm rating ..... E3

Tapped modified head to ..... T  
to allow 50-01 bracket assy.

# MINIATURE Stainless Steel General Purpose Filters

# F50S Models Port Size: 1/4

Model Shown: BF50S-2V



- ◆ Meets **NACE** specifications.
- ◆ High-strength stainless steel filter bowl. Stainless steel construction provides unique corrosion resistance.
- ◆ Viton elastomers throughout.
- ◆ Inline mounting.
- ◆ 5- $\mu$ m-rated polyethylene filter element; optional sintered bronze elements.
- ◆ Manual drain.
- ◆ **NPTF** port threads; optional **BSPP** threads.

## SPECIFICATIONS

**Ambient/Media Temperature:**

40° to 150°F (4° to 66°C).

**Body:** Stainless steel.

**Bowl:** 2-Ounce (60-ml) capacity stainless steel.

**Bowl Drain:** Manual.

**Filter Element:** 5- $\mu$ m-rated polyethylene; optional 5- $\mu$ m, 20- $\mu$ m, or 40- $\mu$ m sintered bronze.

**Fluid Media:** Compressed air.

**Inlet Pressure:** 0 to 200 psig (14 bar) maximum.

**Seals:** Viton

## FLOW CHART

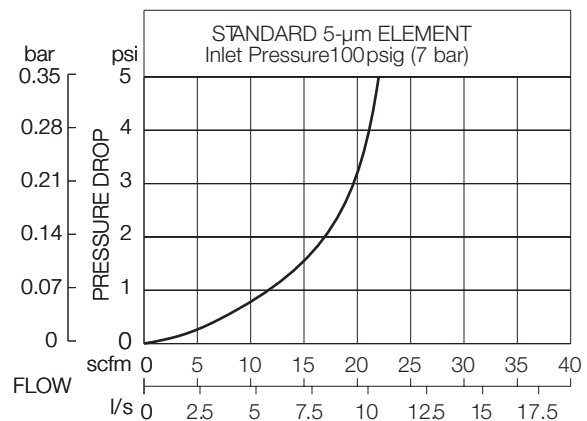

**DIMENSIONS** inches (mm)

Bowl	Ports	A	B	C	Depth	Weight
						lb (kg)
Plastic	1/4	1.6 (41)	3.6 (92)	0.4 (9.5)	1.6 (41)	0.33 (0.15)
Metal	1/4	1.6 (41)	4.3 (109)	0.4 (9.5)	1.6 (41)	0.35 (0.16)

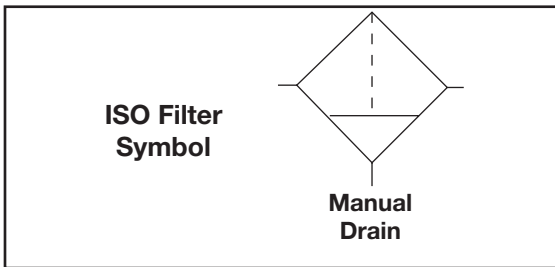
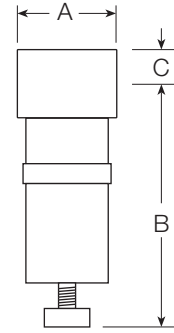

**REPLACEMENT FILTER ELEMENT KITS**

Element Type	Kit Number
5-µm polyethylene (Std element).....	KA130-27PE5
5-µm bronze .....	KA130-27E5
20-µm bronze .....	KA130-27E4
40-µm bronze .....	KA130-27E3

**ORDERING INFORMATION**

Change the letters in the sample model number below to specify the filter you want.

**B F 50S - 2 Y V W**

**BOWL TYPE**

Plastic bowl ..... Leave blank  
 Metal bowl..... B

**PORT TYPE**

NPTF Threads ..... Leave Blank  
 BSPP threads ..... W

**OPTIONS:** (*More than one option can be chosen*)

None.....Leave Blank

**Sintered bronze filter element:**

5-µm rating ..... E5  
 20-µm rating ..... E4  
 40-µm rating ..... E3  
 Tapped modified head to ..... T  
 to allow 50-01 bracket assy.

# GUARDSMAN Modular General Purpose Filters

# FD60 Models Port Sizes: 1/4, 3/8, 1/2



Model Shown: F60-2

- ◆ Modular or inline mounting.
- ◆ 5- $\mu$ m-rated polyethylene filter element; optional sintered bronze elements.
- ◆ High-strength polycarbonate plastic filter bowl with zinc shatterguard; optional zinc bowl.
- ◆ Internal automatic drain; optional manual drain.
- ◆ **NPTF** port threads; optional **SAE** or **BSPP** threads.

## SPECIFICATIONS

### Ambient/Media Temperature:

**Plastic Bowl:** 40° to 125°F (4° to 52°C).

**Metal Bowl:** 40° to 175°F (4° to 79°C).

**Body:** Zinc.

**Bowl:** 4-Ounce (120-ml) capacity polycarbonate plastic with zinc shatterguard; optional zinc bowl.

### Bowl Drain:

Internal automatic drain; optional manual drain.

**Filter Element:** 5- $\mu$ m-rated polyethylene; optional 5- $\mu$ m, 20- $\mu$ m, or 40- $\mu$ m sintered bronze.

**Fluid Media:** Compressed air.

### Inlet Pressure:

15 psig (1 bar) minimum with automatic drain.

**Plastic bowl:** 150 psig (10 bar) maximum.

**Metal bowl:** 200 psig (14 bar) maximum.

**Seals:** Nitrile.

## FLOW CHART

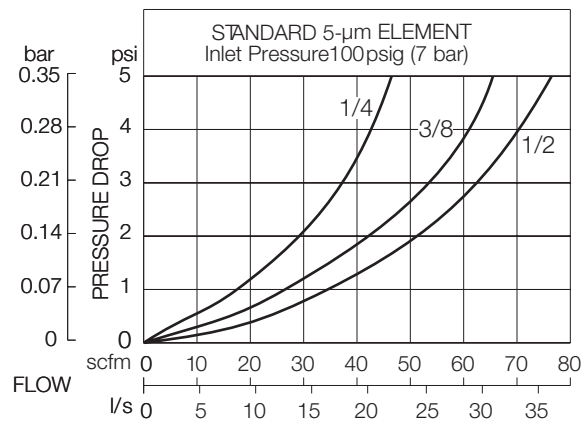

**DIMENSIONS** inches (mm)

Bowl	Ports	A	B	C	Depth	Weight lb (kg)
Plastic	1/4 – 1/2	2.7 (67)	4.8 (122)	0.6 (16)	2.4 (60)	1.13 (0.51)
Metal	1/4 – 1/2	2.7 (67)	4.9 (123)	0.6 (16)	2.4 (60)	1.50 (0.68)

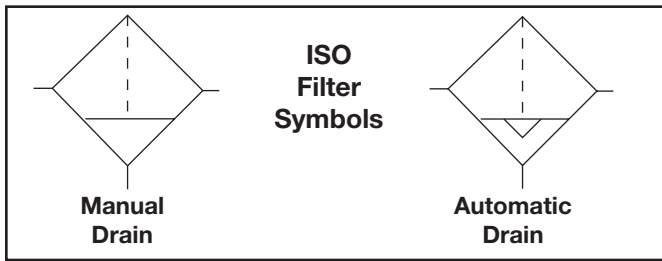
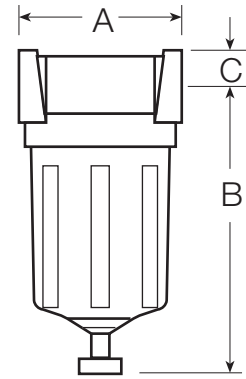

**REPLACEMENT FILTER ELEMENT KITS**

Element Type	Kit Number
5-µm polyethylene (Std element)	KA60F-03
5-µm bronze	KA60F-03E5
20-µm bronze	KA60F-03E4
40-µm bronze	KA60F-03E3

**ORDERING INFORMATION**

Change the letters in the sample model number below to specify the filter you want.

**B FD 60 - 2 Y W**

**BOWL TYPE**

Plastic bowl ..... Leave blank  
Metal bowl ..... B

**BOWL DRAIN**

Internal automatic drain ..... FD  
Manual drain ..... F

**PORT SIZE**

1/4 NPTF ..... 2  
3/8 NPTF ..... 3  
1/2 NPTF ..... 4  
9/16-18 UNF SAE ..... S6

**PORT TYPE**

NPTF Threads ..... Leave Blank  
BSPP threads ..... W

**OPTIONS**

None ..... Leave Blank

**Sintered bronze filter element:**

5-µm rating ..... E5  
20-µm rating ..... E4  
40-µm rating ..... E3

**General Purpose FILTERS**

# GUARDSMAN II Modular General Purpose Filters

# BFD70 Models Port Sizes: 1/4, 3/8, 1/2



Model Shown: BFD740-4

- ◆ Modular or inline mounting.
- ◆ 5- $\mu$ m-rated polyethylene filter element; optional sintered bronze elements.
- ◆ Metal bowl with clear nylon sight glass. Bowl can be rotated for easy readability.
- ◆ Optional extended bowl for greater sump capacity.
- ◆ Internal automatic drain; optional manual drain.
- ◆ NPTF port threads; optional SAE or BSPP threads.

## SPECIFICATIONS

### Ambient/Media Temperature:

40° to 175°F (4° to 79°C).

### Body:

Zinc.

**Bowl:** 6-Ounce (180-ml) capacity aluminum with clear nylon sight glass. Bowl can be rotated for easy readability. Optional 10-ounce (300-ml) extended aluminum bowl for greater sump capacity.

### Bowl Drain:

Internal automatic drain; optional manual drain.

### Bowl Ring:

Nylon.

**Filter Element:** 5- $\mu$ m-rated polyethylene; optional 5- $\mu$ m or 40- $\mu$ m sintered bronze.

**Fluid Media:** Compressed air.

### Inlet Pressure:

Minimum: 15 psig (1 bar) with automatic drain.

Maximum: 200 psig (14 bar)

**Seals:** Nitrile.

## FLOW CHART

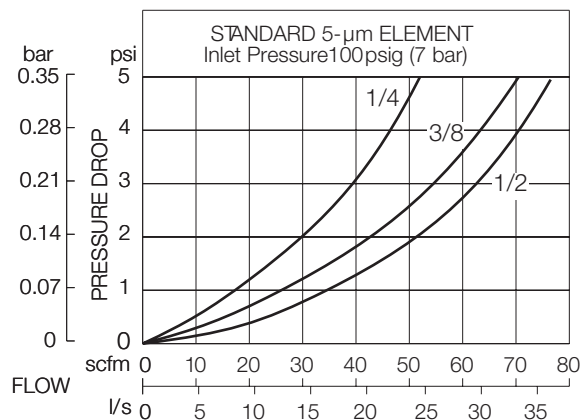



**DIMENSIONS** inches (mm)

Bowl	A	B	C	Depth	Weight lb (kg)
Standard	2.7 (67)	5.9 (151)	0.6 (16)	2.4 (60)	1.25 (0.57)
Extended	2.7 (67)	8.9 (227)	0.6 (16)	2.4 (60)	1.50 (0.68)

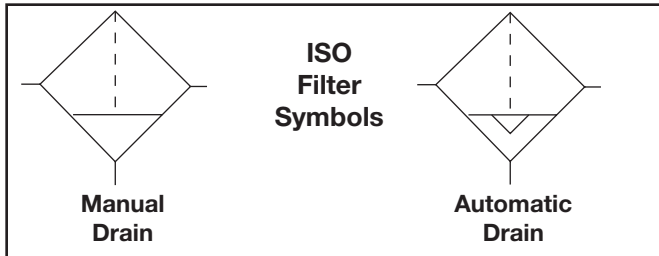
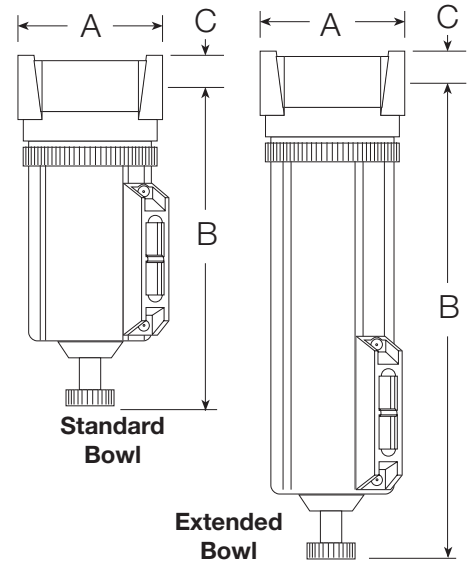

**REPLACEMENT FILTER ELEMENT KITS**

Element Type	Kit Number
5- $\mu$ m polyethylene (Std element)	A60F-03PE5
5- $\mu$ m bronze	KA60F-03E5
40- $\mu$ m bronze	KA60F-03E3

**ORDERING INFORMATION**

Change the letters in the sample model number below to specify the filter you want.

**B FD 70 - 2 Y W**

**BOWL DRAIN**

- Internal automatic drain ..... FD
- Manual drain..... F

**BOWL SIZE**

- Standard 6-ounce bowl ..... 70
- Extended 10-ounce bowl ..... 70H

**PORT SIZE**

- 1/4 NPTF..... 2
- 3/8 NPTF..... 3
- 1/2 NPTF..... 4
- 9/16-18 UNF SAE ..... S6

**PORT TYPE**

- NPTF Threads ..... Leave Blank
- BSPF threads ..... W

**OPTIONS**

- None ..... Leave Blank

**Sintered bronze filter element:**

- 5- $\mu$ m rating ..... E5
- 20- $\mu$ m rating ..... E4
- 40- $\mu$ m rating ..... E3

# Full-Size VANGUARD Modular General Purpose Filters

# FD100 Models Port Sizes: 1/4 to 3/4



Model Shown: FC100-2

- ◆ Modular or inline mounting.
- ◆ 5- $\mu\text{m}$ -rated polyethylene filter element; optional sintered bronze elements.
- ◆ High-strength polycarbonate plastic filter bowl with steel shatterguard; optional metal bowl with clear nylon sight glass.
- ◆ Internal automatic drain; optional manual drain or external Hydro-Jector drain.
- ◆ NPTF port threads; optional SAE or BSPP threads.

## SPECIFICATIONS

### Ambient/Media Temperature:

Plastic bowl: 40° to 125°F (4° to 52°C).  
Metal bowl: 40° to 175°F (4° to 79°C).

**Body:** Zinc.

**Bowl:** 8-Ounce (240-ml) capacity polycarbonate plastic with steel shatterguard; optional zinc bowl with clear nylon sight glass.

**Bowl Drain:** Internal automatic drain; optional manual drain or external Hydro-Jector drain.

**Bowl Ring:** Aluminum.

**Filter Element:** 5- $\mu\text{m}$ -rated polyethylene; optional 5- $\mu\text{m}$ , 20- $\mu\text{m}$ , or 40- $\mu\text{m}$  sintered bronze.

**Fluid Media:** Compressed air.

### Inlet Pressure:

15 psig (1 bar) minimum with automatic drain.  
Plastic Bowl: 150 psig (10 bar) maximum.  
Metal Bowl: 200 psig (14 bar) maximum.

**Seals:** Nitrile.

## FLOW CHART

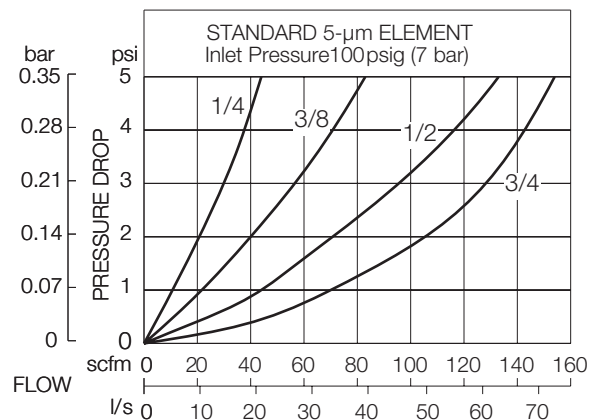

## DIMENSIONS inches (mm)

Bowl	Ports	A	B †	C	Depth	Weight † lb (kg)
Plastic	1/4 – 3/4	3.5 (89)	5.8 (146)	0.6 (16)	3.5 (89)	1.93 (0.88)
Metal	1/4 – 3/4	3.5 (89)	6.4 (163)	0.6 (16)	3.5 (89)	2.90 (1.32)

† With Hydro-Jector external drain, dimension B is increased by 8.0 inches (203 mm), and weight is increased by 2.56 pounds (1.18 kg).

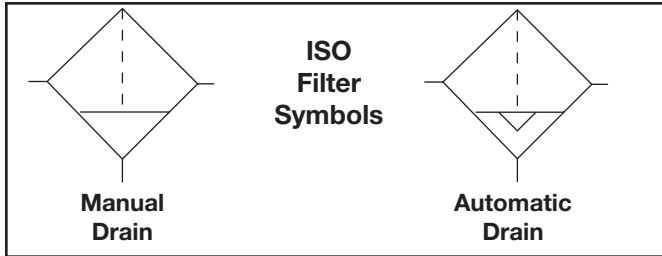
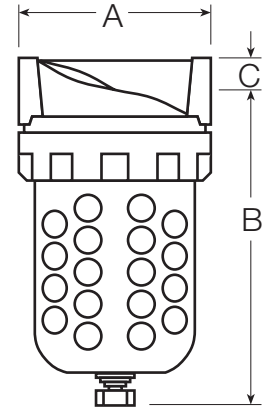

## REPLACEMENT FILTER ELEMENT KITS

Element Type	Kit Number
5-µm polyethylene (Std element).....	KA103-3PE
5-µm bronze.....	KA103-03E5
20-µm bronze.....	KA103-03E4
40-µm bronze.....	KA103-03E3

## ORDERING INFORMATION

Change the letters in the sample model number below to specify the filter you want.

**B FD 100 - 2 Y W**

### BOWL TYPE

Plastic bowl..... Leave blank  
Metal bowl..... B

### BOWL DRAIN

Internal automatic drain..... FD  
Manual drain..... F  
External Hydro-Jector drain..... FE

### DIFFERENTIAL PRESSURE GAUGE

No gauge..... 100  
Large gauge..... 101L  
Small gauge..... 101  
Reed Switch Large Gauge..... 101E  
normally open.  
Reed Switch Large Gauge..... 101E2  
normally closed.

### PORT TYPE

NPTF Threads..... Leave Blank  
BSPP threads..... W

### OPTIONS: (More than one option can be chosen)

None..... Leave Blank  
Sintered bronze filter element  
5-µm rating..... E5  
20-µm rating..... E4  
40-µm rating..... E3  
Delete bowl drain..... LDC  
(1/4 NPT female port instead)

### PORT SIZE

1/4 NPTF..... 2  
3/8 NPTF..... 3  
1/2 NPTF..... 4  
3/4 NPTF..... 6X\*  
9/16-18 UNF SAE..... S6  
3/4-16 UNF SAE..... S8  
7/8-14 UNF SAE..... S10

\* Note: "6x", 3/4" NPTF has smaller bowl capacity than "6", 3/4" NPTF

## DIFFERENTIAL PRESSURE GAUGES



Small Slide Gauge  
K103-151



Large Dual Face Gauge  
106-35



Large Dual Face Gauge  
with Reed Switch  
106-35E (Normally Open)  
106-35EC (Normally Closed)

# Full-Size SERIES 380 Modular General Purpose Filters

# FD380 Models Port Sizes: 3/8, 1/2, 3/4

### Available Color Caps



Model Shown: FD380-6

- ◆ Modular or inline mounting.
- ◆ 5- $\mu$ m-rated polyethylene filter element; optional 40- $\mu$ m element.
- ◆ Polycarbonate plastic bowl with steel shatter-guard; optional metal bowl with sight glass.
- ◆ Internal automatic drain; optional manual drain, Hydro-Jector drain, or Warrior electronic drain.
- ◆ NPTF port threads; optional SAE or BSPP threads.

### SPECIFICATIONS

#### Ambient/Media Temperature:

Plastic bowl: 40° to 125°F (4° to 52°C).  
Metal bowl: 40° to 175°F (4° to 79°C).

**Body:** Die-cast zinc.

**Bowl:** 9-Ounce (270-ml) capacity polycarbonate plastic with steel shatterguard; optional aluminum bowl with clear nylon sight glass.

**Bowl Drain:** Internal automatic drain; by removing the adjustment knob, a 3/16" (5mm) flexible tube can be connected to the drain. Optional manual drain, Hydro-Jector drain, or Warrior electronic drain.

**Bowl Ring:** Nylon.

**Cap Color:** Accent grey. Yellow, red, and blue optional.

**Differential Pressure Gauge:** Optional.

**Filter Element:** 5- $\mu$ m-rated polyethylene; optional 40- $\mu$ m element.

**Fluid Media:** Compressed air.

#### Inlet Pressure:

15 psig (1 bar) minimum with automatic drain.  
Plastic bowl: 150 psig (10 bar).  
Metal bowl: 200 psig (14 bar).

**Seals:** Nitrile

### FLOW CHARTS (5- $\mu$ m element)

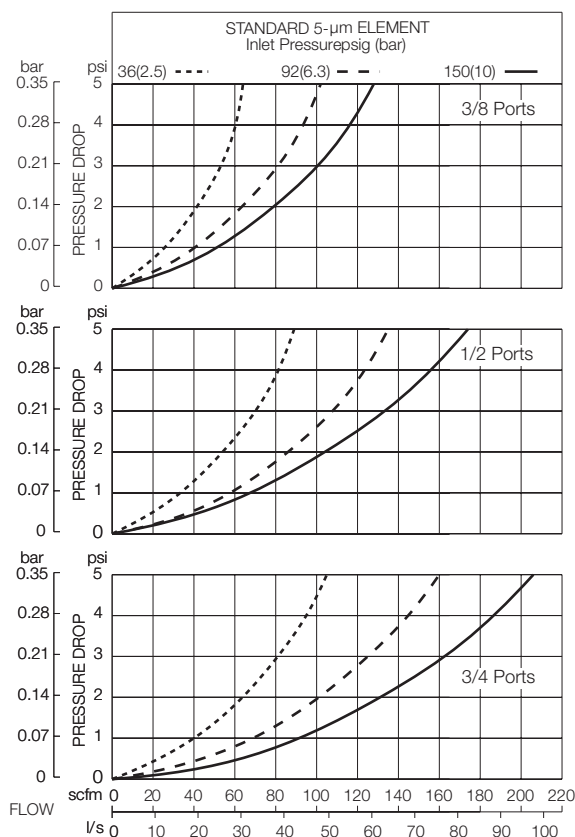

### DIMENSIONS inches (mm)

Bowl	A	B †	C	Depth	Weight lb (kg)
Plastic	3.5 (88)	7.7 (195)	1.1 (28)	2.9 (73)	2.13 (0.97)
Metal	3.5 (88)	7.6 (193)	1.1 (28)	3.1 (79)	2.13 (0.97)

† Bowl removal clearance: add 3.1 (79).

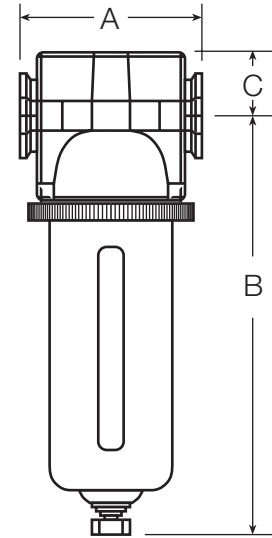

### REPLACEMENT FILTER ELEMENT KITS

Element Rating	Kit Number
5-µm Polyethyelene (Std element)	A115-106PE5
40-µm Polyethyelene	A115-106PE3
5-µm Bronze	A115-106E5
20-µm Bronze	A115-106E4

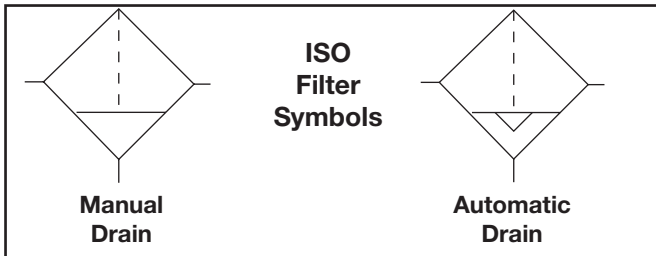

### ORDERING INFORMATION

Change the letters in the sample model number below to specify the filter you want.

**B FD 380 - 3 Y W**

#### BOWL TYPE

Plastic with guard ..... Leave Blank  
Metal with sight glass ..... B

#### BOWL DRAIN

Internal automatic drain ..... FD  
Manual drain ..... F  
External Hydro-Jector drain; ..... FE  
only with metal bowl  
Warrior electronic drain; ..... F2A  
only with metal bowl

#### DIFFERENTIAL PRESSURE GAUGE

No gauge ..... 380  
Large gauge ..... 380L  
Small gauge ..... 380S  
Reed Switch Large Gauge .... 380E  
normally open.  
Reed Switch Large Gauge .... 380E2  
normally closed.

#### DIFFERENTIAL PRESSURE GAUGES

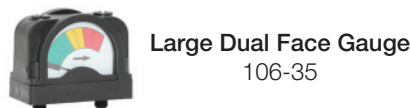

#### PORT TYPE

NPTF Threads ..... Leave Blank  
BSPP threads ..... W

#### OPTIONS: (More than one option can be chosen)

None ..... Leave Blank

#### Cap color: Grey is standard.

MP yellow ..... C1  
Red ..... C2  
Mid blue ..... C3  
40-µm rated filter element ..... E3  
Sintered bronze filter element  
5-µm rating ..... E5  
20-µm rating ..... E4

#### PORT SIZE

3/8 NPTF ..... 3  
1/2 NPTF ..... 4  
3/4 NPTF ..... 6  
3/4-16 UNF SAE ..... S8  
7/8-14 UNF SAE ..... S10

# High-Capacity VANGUARD General Purpose Filters

# FD100 Models Port Sizes: 3/4, 1



Model Shown: FD100-8

- ◆ Inline mounting.
- ◆ 5- $\mu$ m-rated polyethylene filter element; optional sintered bronze elements.
- ◆ High-strength polycarbonate plastic filter bowl with steel shatterguard; optional metal bowl with clear nylon sight glass.
- ◆ Internal automatic drain; optional manual drain or external Hydro-Jector drain.
- ◆ NPTF port threads; optional SAE or BSPP threads.

## SPECIFICATIONS

### Ambient/Media Temperature:

Plastic Bowl: 40° to 125°F (4° to 52°C).

Metal Bowl: 40° to 175°F (4° to 79°C).

**Bowl:** Aluminum.

**Bowl:** 16-Ounce (480-ml) capacity polycarbonate plastic with steel shatterguard; optional aluminum bowl with clear nylon sight glass.

**Bowl Drain:** Internal automatic drain; optional manual drain or external Hydro-Jector drain.

**Bowl Ring:** Aluminum.

**Filter Element:** 5- $\mu$ m-rated polyethylene; optional 5- $\mu$ m, 20- $\mu$ m, or 40- $\mu$ m sintered bronze.

**Fluid Media:** Compressed air.

### Inlet Pressure:

15 psig (1 bar) minimum with automatic drain.

Plastic Bowl: 150 psig (10 bar) maximum.

Metal Bowl: 200 psig (14 bar) maximum.

**Seals:** Nitrile.

## FLOW CHART

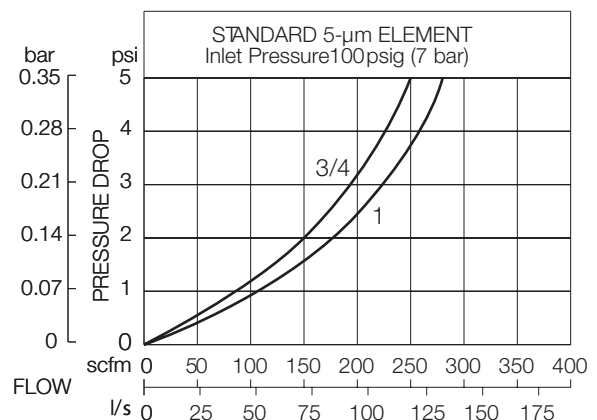

## DIMENSIONS inches (mm)

Bowl	Ports	A	B †	C	Depth	Weight † lb (kg)
Plastic	3/4, 1	4.5 (114)	8.0 (203)	0.8 (21)	4.2 (106)	2.44 (1.11)
Metal	3/4, 1	4.5 (114)	8.3 (210)	0.8 (21)	4.2 (106)	3.25 (1.48)

† With Hydro-Jector external drain, dimension B is increased by 8.0 inches (203 mm), and weight is increased by 2.56 pounds (1.18 kg).

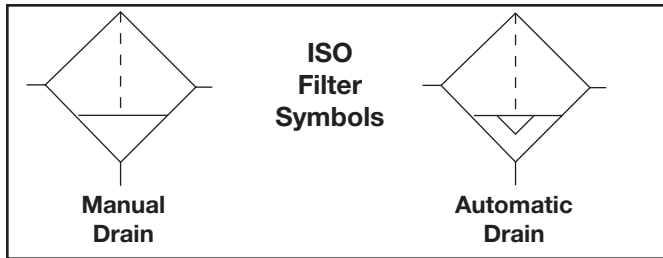
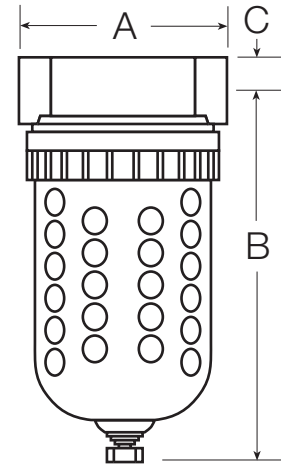

## REPLACEMENT FILTER ELEMENT KITS

Element Type	Kit Number
5-µm polyethylene (Std element)	KA109-3PE
5-µm bronze	KA109-03E5
20-µm bronze	KA109-03E4
40-µm bronze	KA109-03E3

## ORDERING INFORMATION

Change the letters in the sample model number below to specify the filter you want.

**B FD 100 - 6 Y W**

**BOWL TYPE**

Plastic bowl ..... Leave blank  
Metal bowl ..... B

**BOWL DRAIN**

Internal automatic drain ..... FD  
Manual drain ..... F  
External Hydro-Jector drain; ..... FE  
only with metal bowl

**DIFFERENTIAL PRESSURE GAUGE**

No gauge ..... 100  
Large gauge ..... 101  
Small gauge ..... 101S  
Reed Switch Large Gauge .... 101E  
normally open.  
Reed Switch Large Gauge .... 101E2  
normally closed.

**PORT TYPE**

NPTF Threads ..... Leave Blank  
BSP threads ..... W

**OPTIONS:** (*More than one option can be chosen*)

None ..... Leave Blank  
Sintered bronze filter element  
5-µm rating ..... E5  
20-µm rating ..... E4  
40-µm rating ..... E3  
Delete bowl drain; 1/4 NPT .... LDC  
female port instead

**PORT SIZE**

3/4 NPTF ..... 6\*  
1 NPTF ..... 8  
1-1/16-12 UNF SAE ..... S12  
1-5/16-12 UNF SAE ..... S16

## DIFFERENTIAL PRESSURE GAUGES



**Small Slide Gauge**  
K103-151



**Large Dual Face Gauge**  
106-35



**Large Dual Face Gauge with Reed Switch**  
106-35E (*Normally Open*)  
106-35EC (*Normally Closed*)

\* **Note:** "6", 3/4" NPTF has larger bowl capacity than "6x", 3/4" NPTF

# High-Capacity VANGUARD General Purpose Filters

# BFD100 Models Port Sizes: 1-1/4, 1-1/2, & 2



Model Shown: BFD100-10



## SPECIFICATIONS

**Ambient/Media Temperature:**

40° to 175°F (4° to 79°C).

**Body:** Aluminum.

**Bowl:** 123-Ounce (3700-ml) capacity aluminum bowl.

**Bowl Drain:** Internal automatic drain; optional manual drain or external Hydro-Jector drain.

**Filter Element:** 40- $\mu$ m-rated sintered bronze; optional 5- $\mu$ m sintered bronze.

**Fluid Media:** Compressed air.

**Inlet Pressure:**

15 psig (1 bar) minimum with automatic drain.  
200 psig (14 bar) maximum.

**Seals:** Nitrile.

- ◆ Inline mounting.
- ◆ 40- $\mu$ m-rated sintered bronze filter element; optional 5- $\mu$ m sintered bronze element.
- ◆ Aluminum bowl.
- ◆ Internal automatic drain; optional manual drain or external Hydro-Jector drain.
- ◆ **NPTF** port threads; optional **SAE** or **BSPP** threads.

## FLOW CHARTS

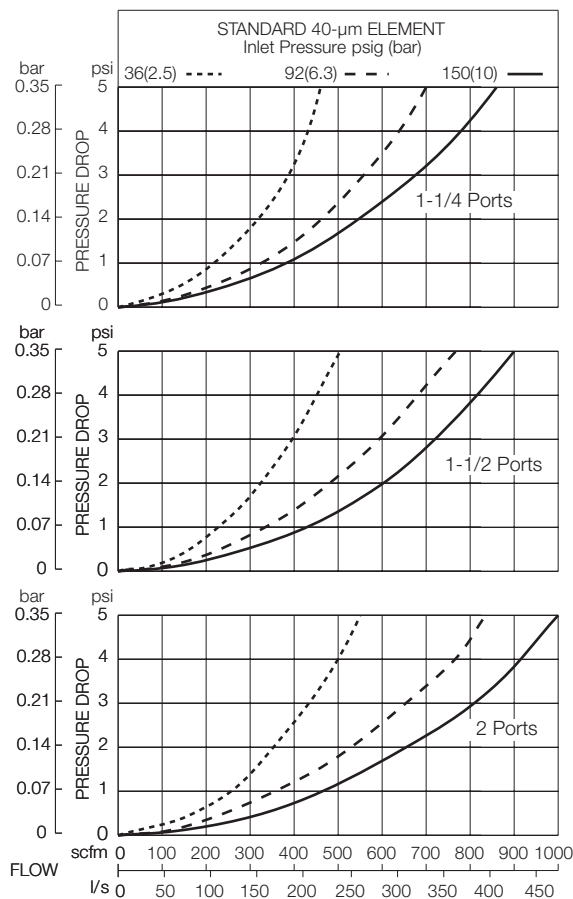



**DIMENSIONS** inches (mm)

A	B †	C	Depth	Weight † lb (kg)
8.0 (203)	13.3 (337)	1.8 (45)	7.3 (186)	14.3 (6.59)

† With Hydro-Jector external drain, dimension B is increased by 8.0 inches (203 mm), and weight is increased by 2.56 pounds (1.18 kg).

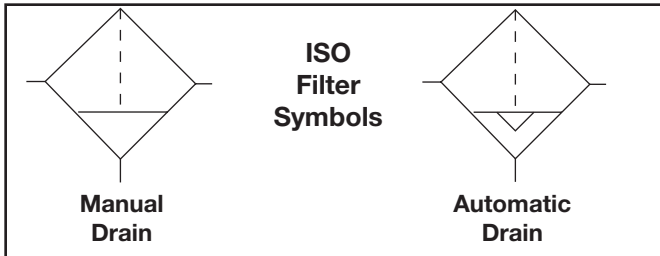
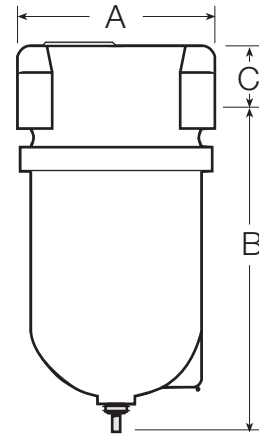

**REPLACEMENT FILTER ELEMENT KITS**

Element Type	Kit Number
40-µm bronze (Std element)	K106-33
5-µm bronze	K106-33E5

**ORDERING INFORMATION**

Change the letters in the sample model number below to specify the filter you want.

**B FD 100 - 10 Y W**

**BOWL DRAIN**

- Internal automatic drain ..... FD
- Manual drain..... F
- External Hydro-Jector drain ..... FE

**DIFFERENTIAL PRESSURE GAUGE**

- No gauge ..... 100
- Large gauge ..... 101
- Small gauge ..... 101S
- Reed Switch Large Gauge .... 101E normally open.
- Reed Switch Large Gauge .... 101E2 normally closed.

**DIFFERENTIAL PRESSURE GAUGES**



**Small Slide Gauge**  
K103-151



**Large Dual Face Gauge**  
106-35



**Large Dual Face Gauge with Reed Switch**  
106-35E (Normally Open)  
106-35EC (Normally Closed)

**PORT TYPE**

- NPTF Threads ..... Leave Blank
- BSPP threads ..... W

**OPTIONS:** (More than one option can be chosen)

- None ..... Leave Blank
- Sintered bronze filter element
- 5-µm rating ..... E5
- Delete bowl drain; 1/4 NPT .... LDC female port instead

**PORT SIZE**

- 1-1/4 NPTF ..... 10
- 1-1/2 NPTF ..... 12
- 2 NPTF ..... 16
- 1-5/8-12 UNF SAE ..... S20
- 1-7/8-12 UNF SAE ..... S24

# High-Capacity VANGUARD General Purpose Filters

# BFD200 Models Port Sizes: 3/4, 1



**Model Shown:** BFD200-6

- ◆ Inline mounting.
- ◆ 40- $\mu$ m-rated sintered bronze filter element; optional 5- $\mu$ m-rated sintered bronze element.
- ◆ Aluminum bowl with clear nylon sight glass.
- ◆ Optional differential pressure gauge.
- ◆ Internal automatic drain; optional manual drain or external Hydro-Jector drain.
- ◆ **NPTF** port threads; optional **SAE** or **BSPP** threads.

## SPECIFICATIONS

**Ambient/Media Temperature:**

40° to 175°F (4° to 79°C).

**Body:** Aluminum.

**Bowl:** 35-Ounce (1 liter) aluminum bowl with clear nylon sight glass.

**Bowl Drain:** Internal automatic drain; optional manual drain or external Hydro-Jector drain.

**Bowl Ring:** Aluminum.

**Differential Pressure Gauge:** Optional.

**Filter Element:** 40- $\mu$ m-rated sintered bronze; optional 5- $\mu$ m sintered bronze.

**Fluid Media:** Compressed air.

**Inlet Pressure:**

15 psig (1 bar) minimum with automatic drain.

200 psig (14 bar) maximum.

**Seals:** Nitrile.

## FLOW CHART

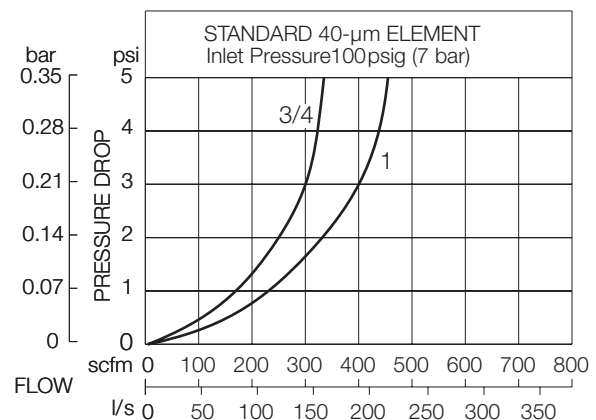

**DIMENSIONS** inches (mm)

A	B †	C	Depth	Weight † lb (kg)
4.5 (114)	10.3 (263)	1.0 (25)	4.2 (106)	4.25 (193)

† With Hydro-Jector external drain, dimension B is increased by 8.0 inches (203 mm), and weight is increased by 2.56 pounds (1.18 kg).

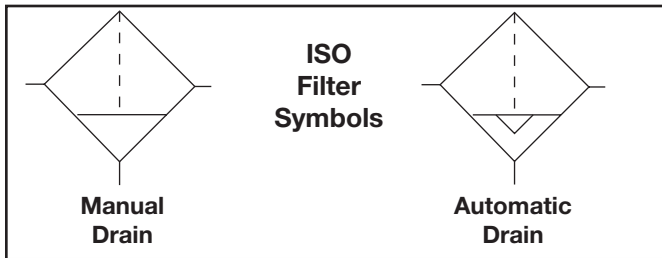
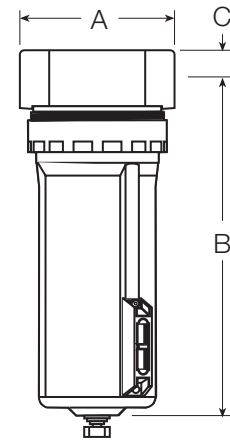

**REPLACEMENT FILTER ELEMENT KITS**

Element Type	Kit Number
40-µm bronze (Std element)	A114-106E3
5-µm bronze	A114-106E5

**ORDERING INFORMATION**

Change the letters in the sample model number below to specify the filter you want.

**B FD 200 - 6 Y W**

**BOWL DRAIN**

- Internal automatic drain ..... FD
- Manual drain..... F
- External Hydro-Jector drain ..... FE

**DIFFERENTIAL PRESSURE GAUGE**

- No gauge ..... 200
- Large gauge ..... 201
- Small Gauge ..... 201S
- Reed Switch Large Gauge .... 201E normally open.
- Reed Switch Large Gauge .... 201E2 normally closed.

**DIFFERENTIAL PRESSURE GAUGES**



Small Slide Gauge  
K103-151



Large Dual Face Gauge  
106-35



Large Dual Face Gauge  
with Reed Switch  
106-35E (Normally Open)  
106-35EC (Normally Closed)

**PORT TYPE**

- NPTF Threads ..... Leave Blank
- BSPB threads ..... W

**OPTIONS:** (More than one option can be chosen)

- None ..... Leave Blank
- Sintered bronze filter element ... E5  
5-µm rating
- Delete bowl drain; 1/4 NPT .... LDC  
female port instead

**PORT SIZE**

- 3/4 NPTF..... 6
- 1 NPTF..... 8
- 1-1/16-12 UNF SAE ..... S12
- 1-5/16-12 UNF SAE ..... S16

General Purpose  
FILTERS

# High-Capacity VANGUARD General Purpose Filters

# BFD200 Models Port Sizes: 1-1/4, 1-1/2



Model Shown: BFD200-10

- ◆ Inline mounting.
- ◆ 40- $\mu$ m-rated sintered bronze filter element; optional 5- $\mu$ m-rated sintered bronze element.
- ◆ Aluminum bowl with clear nylon sight glass.
- ◆ Optional differential pressure gauge.
- ◆ Internal automatic drain; optional manual drain or external Hydro-Jector drain.
- ◆ NPTF port threads; optional SAE or BSPP threads.

## SPECIFICATIONS

### Ambient/Media Temperature:

40° to 175°F (4° to 79°C).

**Body:** Aluminum.

**Bowl:** 35-Ounce (1 liter) aluminum bowl with clear nylon sight glass.

**Bowl Drain:** Internal automatic drain; optional manual drain or external Hydro-Jector drain.

**Bowl Ring:** Aluminum.

**Differential Pressure Gauge:** Optional.

**Filter Element:** 40- $\mu$ m-rated sintered bronze; optional 5- $\mu$ m sintered bronze.

**Fluid Media:** Compressed air.

### Inlet Pressure:

15 psig (1 bar) minimum with automatic drain.

200 psig (14 bar) maximum.

**Seals:** Nitrile.

## FLOW CHARTS

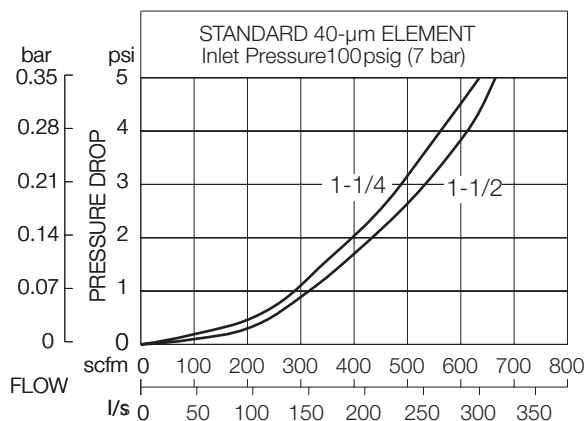
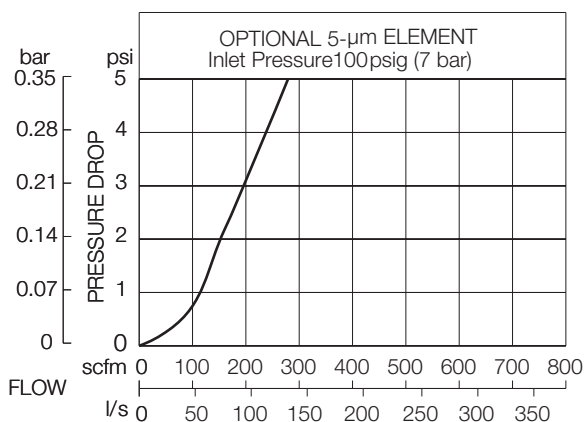

**DIMENSIONS** inches (mm)

A	B †	C	Depth	Weight † lb (kg)
5.5 (140)	10.7 (271)	1.4 (36)	4.2 (106)	4.50 (2.04)

† With Hydro-Jector external drain, dimension B is increased by 8.0 inches (203 mm), and weight is increased by 2.56 pounds (1.18 kg).

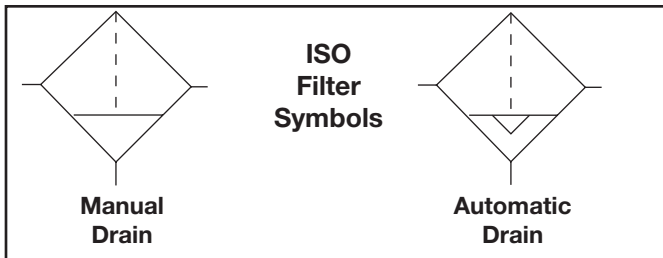
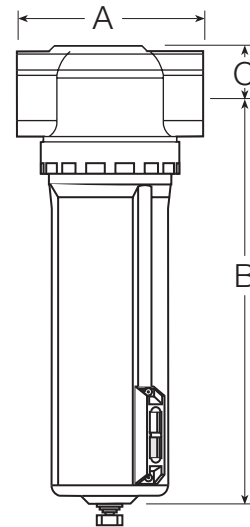

**REPLACEMENT FILTER ELEMENT KITS**

Element Type	Kit Number
40-µm bronze (Std element)	A114-106E3
5-µm bronze	A114-106E5

**ORDERING INFORMATION**

Change the letters in the sample model number below to specify the filter you want.

**B FD 200 - 10 Y W**

**BOWL DRAIN**

- Internal automatic drain ..... FD
- Manual drain..... F
- External Hydro-Jector drain ..... FE

**DIFFERENTIAL PRESSURE GAUGE**

- No gauge ..... 200
- Large gauge ..... 201
- Small gauge ..... 201S
- Reed Switch Large Gauge .... 201E normally open.
- Reed Switch Large Gauge .... 201E2 normally closed.

**DIFFERENTIAL PRESSURE GAUGES**



**Small Slide Gauge**  
K103-151



**Large Dual Face Gauge**  
106-35



**Large Dual Face Gauge with Reed Switch**  
106-35E (Normally Open)  
106-35EC (Normally Closed)

**PORT TYPE**

- NPTF Threads ..... Leave Blank
- BSPB threads ..... W

**OPTIONS:** (More than one option can be chosen)

- None ..... Leave Blank
- Sintered bronze filter element**
- 5-µm rating..... E5
- Delete bowl drain; 1/4 NPT ..... LDC female port instead

**PORT SIZE**

- 1-1/4 NPTF ..... 10
- 1-1/2 NPTF ..... 12
- 1-5/8-12 UNF SAE ..... S20
- 1-7/8-12 UNF SAE ..... S24

# COALESCING FILTERS

A 0.3- $\mu\text{m}$ -rated coalescing filter element is standard in all coalescing units. They remove 99.99% of oil and solid contaminants larger than 0.3  $\mu\text{m}$ . An optional 0.01- $\mu\text{m}$ -rated element provides extremely fine filtration, but at some reduction in air flow. However, in **GUARDSMAN**, **GUARDSMAN II**, **SERIES 380**, and **VANGUARD** filters there are available extended bowls with higher capacity coalescing elements for significantly increased air flows.

Coalescing filters have epoxy-resin-coated, borosilicate, glass-fiber elements. Liquids and solids are removed from the air stream by several different actions, namely:



**IMPACTION:** Particles larger than 1  $\mu\text{m}$  collide with and adhere to the fibers of the element.

**INTERCEPTION:** Particles 0.3  $\mu\text{m}$  to 2  $\mu\text{m}$  in size are molecularly attracted to the fibers of the element, and this causes them to adhere.

**DIFFUSION:** Particles 0.001  $\mu\text{m}$  to 0.3  $\mu\text{m}$  in size move by random Brownian motion, thereby contacting and adhering to the fibers of the element.

**DRAINING:** Tiny droplets of oil coalesce (merge) until they form drops large enough to fall off the filter element and into the bowl sump. The automatic drain then expels them.

The filter element will continue to coalesce liquids until solid contaminants accumulated in the filter element cause the pressure drop across the element to become excessive. At this point the filter element must be changed. A built-in differential pressure gauge (see next page) will indicate when the point is reached that requires the element to be changed.

## GUIDE to COALESCING FILTERS

Filter Series	Modular Construction	Port Sizes								Pages	
		1/8	1/4	3/8	1/2	3/4	1	1-1/4	1-1/2		2
<b>SENTRY</b>											
FCD10 models †	yes	X	X								72-73
<b>MINIATURE</b>											
FCD50 models	no	X	X								74-75
<b>GUARDSMAN</b>											
FCD60 models	yes		X	X	X						76-77
<b>GUARDSMAN II</b>											
BFCD70 models	yes		X	X	X						78-79
<b>Full-Size VANGUARD</b>											
FCD101 models	yes		X	X	X	X					80-81
<b>Full-Size SERIES 380</b>											
FCD380 models	yes			X	X	X					82-83
<b>High-Capacity VANGUARD</b>											
FCD101 models	no					X	X	X	X	X	84-89
BFCD201 models	no					X	X	X	X		90-93

† Also available with quick-connect tube fittings up to 10 mm.

## DIFFERENTIAL PRESSURE GAUGES

**GUARDSMAN, SERIES 380**, and **VANGUARD** coalescing filters include a differential pressure gauge which measures the pressure drop across the coalescing filter element. This monitors the condition of the coalescing element, and such a gauge should always be used with coalescing filters. When the pressure drop increases into the range of 7 to 10 psi (0.5 to 0.7 bar) the gauge indicates that the element must be changed. The types of gauges are shown below.



The Full-Size **VANGUARD** and **SERIES 380** filters use the small **K103-151** gauge kit. **GUARDSMAN** units use the **A60F-28** gauge kit. Both are slide-type gauges, and are color coded to show the condition of the coalescing element.

**Green** — Clean (Up to 7 psi)  
**Red** — Change (7 to 10 psi)



**High-Capacity VANGUARD** filters employ the large **106-35** gauge as shown above. It is a dual face gauge color coded to show the condition of the coalescing element. Optionally available for other units.

**Green** — Clean (Up to 6 psi)  
**Yellow** — Change (6 to 9 psi)  
**Red** — Dirty (Over 9 psi)



The large gauge is also available with a reed switch: normally open (**106-35E**) or normally closed (**106-35EC**). See options for specific filters under Ordering Information. Gauge face readings are unchanged.

**Green** — Clean (Up to 6 psi)  
**Yellow** — Change (6 to 9 psi)  
**Red** — Dirty (Over 9 psi)

### IMPORTANT NOTE

A general purpose filter must be installed ahead of a coalescing filter to ensure good performance and to extend the life of the coalescing element.

## INTERNAL AUTOMATIC BOWL DRAIN

Automatic drains are standard on Master Pneumatic coalescing filters and we strongly recommend their use to improve filter effectiveness, lengthen service life, and reduce maintenance needs.

The Master Pneumatic automatic drains operate when liquids have accumulated in the filter bowl and a pressure drop of 2 psi or more occurs (e.g., when a valve or other device is actuated). The pressure drop triggers the automatic drain to expel accumulated liquid.

The drain is also activated whenever the air supply is shut down and exhausted. Although the unit is set at the factory an adjusting knob at the bottom of the filter can be manually set for optimum performance with very high or low flows of air.

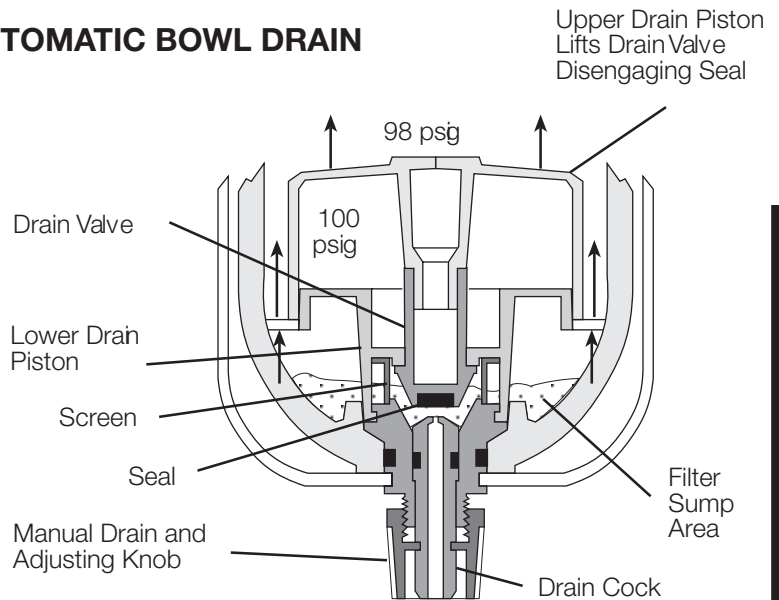

Vanguard Internal Automatic Bowl Drain

# SENTRY Modular Coalescing Filters

# FCD10 Models Port Sizes: 1/8, 1/4; Tube Fittings



Model Shown: FCD10-2

## SPECIFICATIONS

### Ambient/Media Temperature:

40° to 125°F (4° to 52°C).

### Body:

Acetal.  
Bowl: 2-Ounce (60-ml) capacity polycarbonate plastic; optional aluminum bowl.

### Bowl Drain:

Internal automatic drain; optional manual drain.

**Filter Element:** 0.3- $\mu$ m-rated borosilicate-glass-fiber coalescing element; optional 0.01- $\mu$ m-rated element.

**Fluid Media:** Compressed air.

### Inlet Pressure:

15 psig (1 bar) minimum with automatic drain.  
150 psig (10 bar) maximum.

**Seals:** Nitrile.

**APPLICATION NOTE:** A general purpose filter must be installed ahead of a coalescing filter to ensure good performance and to extend the life of the coalescing element.

- ◆ Modular assembly and mounting.
- ◆ Threaded ports or quick-connect fittings for tubing up to 10 mm in diameter.
- ◆ 0.3- $\mu$ m-rated coalescing filter element; optional 0.01- $\mu$ m-rated element.
- ◆ High-strength polycarbonate plastic filter bowl; optional aluminum bowl.
- ◆ Internal automatic drain; optional manual drain.
- ◆ NPTF port threads; optional BSPP threads.

## FLOW CHARTS

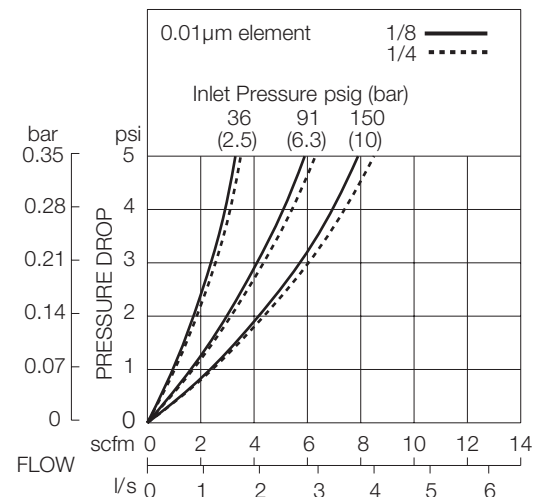
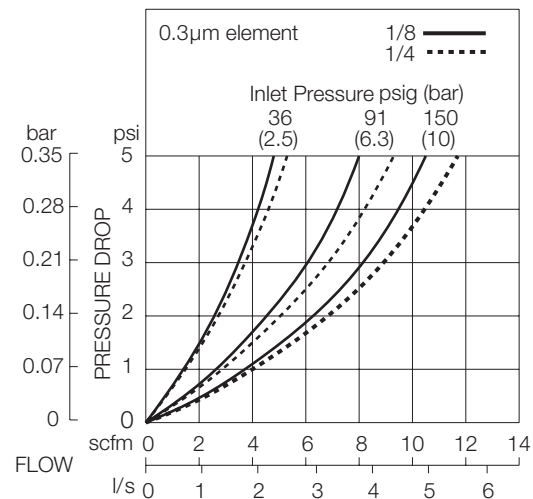



## DIMENSIONS inches (mm)

Ports	A	B †	C	Depth	Weight lb (kg)
No Port	1.7 (43)	3.6 (92)	0.5 (13)	1.8 (45)	0.27 (0.12)
1/8, 1/4	3.0 (76)	3.6 (92)	0.5 (13)	1.8 (45)	0.49 (0.22)
<b>Models below have quick-connect fittings for tubing.</b>					
1/4	3.4 (86)	3.6 (92)	0.5 (13)	1.8 (45)	0.47 (0.21)
3/8	3.9 (99)	3.6 (92)	0.5 (13)	1.8 (45)	0.47 (0.21)
4 mm	3.4 (86)	3.6 (92)	0.5 (13)	1.8 (45)	0.47 (0.21)
6 mm	3.4 (86)	3.6 (92)	0.5 (13)	1.8 (45)	0.47 (0.21)
8 mm	3.1 (79)	3.6 (92)	0.5 (13)	1.8 (45)	0.47 (0.21)
10 mm	3.9 (99)	3.6 (92)	0.5 (13)	1.8 (45)	0.47 (0.21)

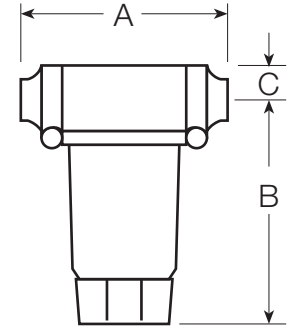

† Dimension for plastic bowl; metal bowl is 4.3 (109).

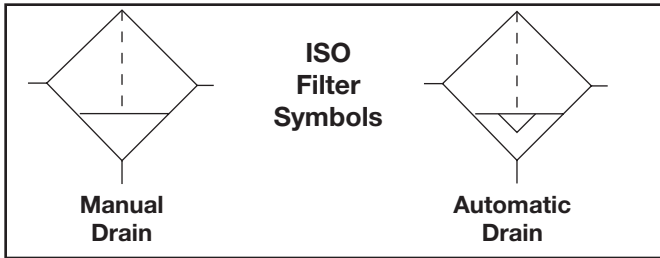

## REPLACEMENT FILTER ELEMENT KITS

Element Rating	Kit Number
0.3 µm (Std element).....	KA10F-09
0.01 µm For models with E8 option.....	KA10F-09E8

## ORDERING INFORMATION

Change the letters in the sample model number below to specify the filter you want.

**B FCD 10 P - 2 X Y W**

### BOWL TYPE

Plastic bowl..... Leave blank  
Metal bowl..... B

### BOWL DRAIN

Internal automatic drain ..... FCD  
Manual drain..... FC

### MOUNTING HOLE LOCATION

Bottom mount (Standard) ..... Leave Blank  
Top mount ..... P

### INLET PORT SIZE

No inlet and outlet ports.. . Leave blank

#### Threaded:

1/8 NPTF ..... 1  
1/4 NPTF ..... 2

#### Fittings for Tubing:

1/4 ..... 04  
3/8 ..... 06  
4 mm ..... M4  
6 mm ..... M6  
8 mm ..... M8  
10 mm ..... M10

### PORT TYPE

As specified in **INLET PORT**... Leave Blank  
BSP threads on both ports..... W

### OPTIONS:

None..... Leave Blank  
0.01-µm-rated coalescing ..... E8 element

### OUTLET PORT SIZE

Same as inlet port ..... Leave Blank

#### Threaded:

1/8 NPTF ..... 1  
1/4 NPTF ..... 2

#### Fittings for Tubing:

1/4 ..... 04  
3/8 ..... 06  
4 mm ..... M4  
6 mm ..... M6  
8 mm ..... M8  
10 mm ..... M10

**Coalescing  
FILTERS**

# MINIATURE Coalescing Filters

# FCD50 Models Port Sizes: 1/8, 1/4



Model Shown: FC50-2

## SPECIFICATIONS

### Ambient/Media Temperature:

Plastic bowl: 40° to 125°F (4° to 52°C).  
Metal bowl: 40° to 150°F (4° to 66°C).

**Body:** Aluminum.

**Bowl:** 2-Ounce (60-ml) capacity polycarbonate plastic; optional aluminum bowl.

### Bowl Drain:

Internal automatic drain; optional manual drain.

**Filter Element:** 0.3- $\mu$ m-rated borosilicate-glass-fiber coalescing element; optional 0.01- $\mu$ m-rated element.

**Fluid Media:** Compressed air.

### Inlet Pressure:

15 psig (1 bar) minimum with automatic drain.  
Plastic bowl: 150 psig (10 bar) maximum.  
Metal bowl: 200 psig (14 bar) maximum.

**Seals:** Nitrile.

**APPLICATION NOTE:** A general purpose filter must be installed ahead of a coalescing filter to ensure good performance and to extend the life of the coalescing element.

- ◆ Inline mounting.
- ◆ 0.3- $\mu$ m-rated coalescing filter element; optional 0.01- $\mu$ m-rated element.
- ◆ High-strength polycarbonate plastic filter bowl; optional metal bowl.
- ◆ Internal automatic drain; optional manual drain.
- ◆ NPTF port threads; optional BSPP threads.

## FLOW CHARTS

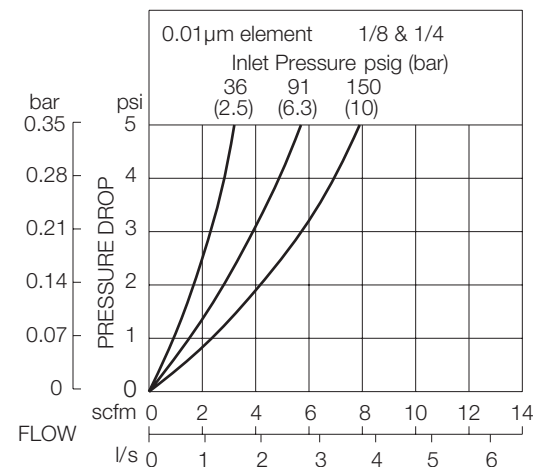
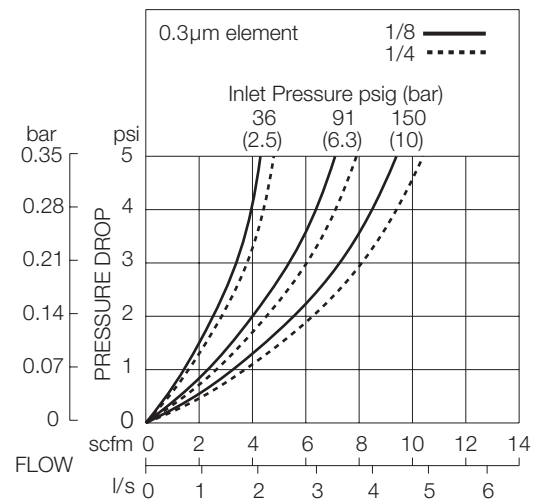

## DIMENSIONS inches (mm)

Bowl	Ports	A	B	C	Depth	Weight lb (kg)
Plastic	1/8, 1/4	1.6 (41)	3.6 (92)	0.4 (9.5)	1.6 (41)	0.33 (0.15)
Metal	1/8, 1/4	1.6 (41)	4.3 (109)	0.4 (9.5)	1.6 (41)	0.35 (0.16)

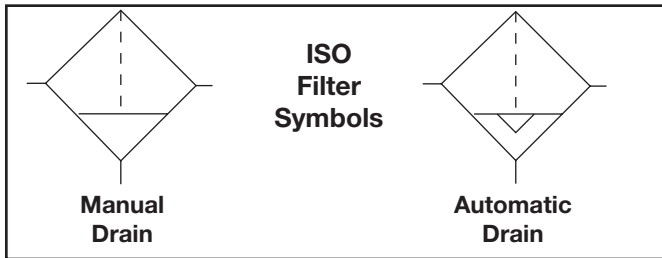
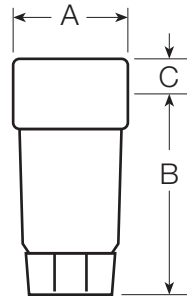

## REPLACEMENT FILTER ELEMENT KITS

Element Rating	Kit Number
0.3 $\mu\text{m}$ (Std element).....	A10F-16
0.01 $\mu\text{m}$ For models with E8 option.....	A10F-16E8

## ORDERING INFORMATION

Change the letters in the sample model number below to specify the filter you want.

**B FCD 50 - 2 Y W**

**BOWL TYPE**

Plastic bowl..... Leave blank  
Metal bowl..... B

**BOWL DRAIN**

Internal automatic drain ..... FCD  
Manual drain..... FC

**PORT TYPE**

NPTF Threads ..... Leave Blank  
BSPP threads ..... W

**OPTIONS:** (*More than one option can be chosen*)

None..... Leave Blank  
0.01- $\mu\text{m}$ -rated coalescing ..... E8  
element  
Tapped modified head to ..... T  
to allow 50-01 bracket assy.

**PORT SIZE**

1/8 NPTF..... 1  
1/4 NPTF..... 2

# GUARDSMAN Modular Coalescing Filters

# FCD60 Models Port Sizes: 1/4, 3/8, 1/2



Model Shown: FCD60-4

## SPECIFICATIONS

### Ambient/Media Temperature:

Plastic Bowl: 40° to 125°F (4° to 52°C).  
Metal Bowl: 40° to 175°F (4° to 79°C).

**Body:** Zinc.

**Bowl:** 4-Ounce (120-ml) capacity polycarbonate plastic with zinc shatterguard; optional zinc bowl.

### Bowl Drain:

Internal automatic drain; optional manual drain.

**Differential Pressure Gauge:** A60F-28.

**Filter Element:** 0.3- $\mu$ m-rated borosilicate-glass-fiber coalescing element; optional 0.01- $\mu$ m-rated element (reduces flow by 20%).

**Fluid Media:** Compressed air.

### Inlet Pressure:

15 psig (1 bar) minimum with automatic drain.  
Plastic bowl: 150 psig (10 bar) maximum.  
Metal bowl: 200 psig (14 bar) maximum.

**Seals:** Nitrile.

- ◆ Modular or inline mounting.
- ◆ 0.3- $\mu$ m-rated coalescing filter element; optional 0.01- $\mu$ m-rated element.
- ◆ High-strength polycarbonate plastic filter bowl with zinc shatterguard; optional zinc bowl.
- ◆ Differential pressure gauge to indicate when filter element needs changing.
- ◆ Internal automatic drain; optional manual drain.
- ◆ **NPTF** port threads; optional **SAE** or **BSP** threads.

## FLOW CHARTS

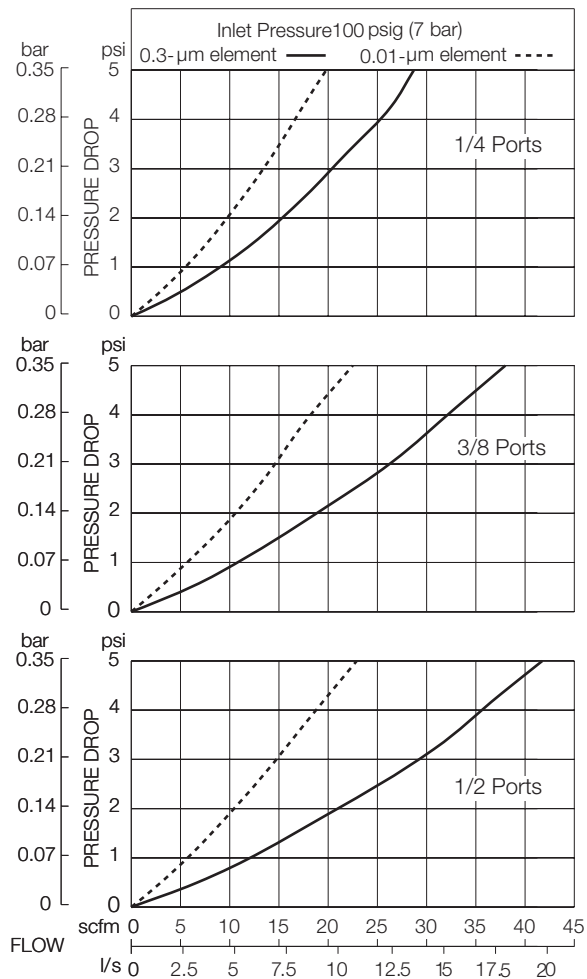

**APPLICATION NOTE:** A general purpose filter must be installed ahead of a coalescing filter to ensure good performance and to extend the life of the coalescing element.

**DIMENSIONS** inches (mm)

Bowl	Ports	A	B	C	Depth	Weight lb (kg)
Plastic	1/4 – 1/2	2.7 (67)	4.8 (122)	1.8 (46)	2.4 (60)	1.13 (0.51)
Metal	1/4 – 1/2	2.7 (67)	4.8 (122)	1.8 (46)	2.4 (60)	1.65 (0.75)

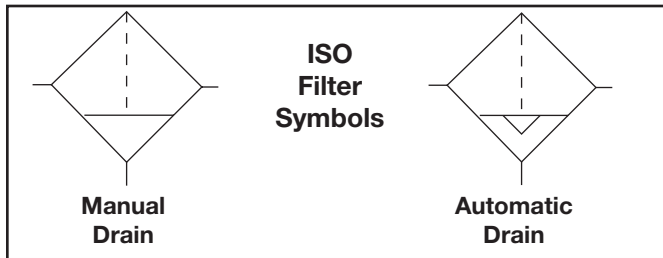
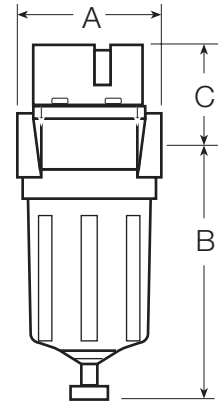

**REPLACEMENT FILTER ELEMENT KITS**

Element Rating	Kit Number
0.3 µm (Std element).....	60F-23
0.01 µm For models with E8 option.....	60F-23E8

**ORDERING INFORMATION**

Change the letters in the sample model number below to specify the filter you want.

**B FCD 60 - 2 Y W**

**BOWL TYPE**

Plastic bowl ..... Leave blank  
Metal bowl..... B

**BOWL DRAIN**

Internal automatic drain ..... FCD  
Manual drain..... FC

**PORT SIZE**

1/4 NPTF..... 2  
3/8 NPTF..... 3  
1/2 NPTF..... 4  
9/16-18 UNF SAE ..... S6

**PORT TYPE**

NPTF Threads ..... Leave Blank  
BSPP threads ..... W

**OPTIONS:**

None..... Leave Blank  
0.01-µm-rated element..... E8

# GUARDSMAN II Modular Coalescing Filters

# BFCD70 Models Port Sizes: 1/4, 3/8, 1/2



Model Shown: BFCD70-4

## SPECIFICATIONS

**Ambient/Media Temperature:**

40° to 175°F (4° to 79°C).

**Body:** Zinc.

**Bowl:** 6-Ounce (180-ml) capacity aluminum with clear nylon sight glass. Bowl can be rotated for easy readability. Optional 10-ounce (300-ml) extended aluminum bowl has higher capacity filter element for increased air flow.

**Bowl Drain:**

Internal automatic drain; optional manual drain.

**Bowl Ring:** Nylon.

**Differential Pressure Gauge:** A60F-28.

**Filter Element:** 0.3- $\mu$ m-rated borosilicate-glass-fiber coalescing element. Optional 0.01- $\mu$ m-rated element (reduces flow by 20%).

**Fluid Media:** Compressed air.

**Inlet Pressure:**

Minimum: 15 psig (1 bar) with automatic drain.

Maximum: 200 psig (14 bar).

**Seals:** Nitrile.

- ◆ Modular or inline mounting.
- ◆ 0.3- $\mu$ m-rated coalescing filter element; optional 0.01- $\mu$ m-rated element.
- ◆ Aluminum bowl with clear nylon sight glass. Bowl can be rotated for easy readability.
- ◆ Optional extended bowl with higher flow filter element.
- ◆ Differential pressure gauge to indicate when filter element needs changing.
- ◆ Internal automatic drain; optional manual drain.
- ◆ **NPTF** port threads; optional **SAE** or **BSP** threads.

## FLOW CHARTS

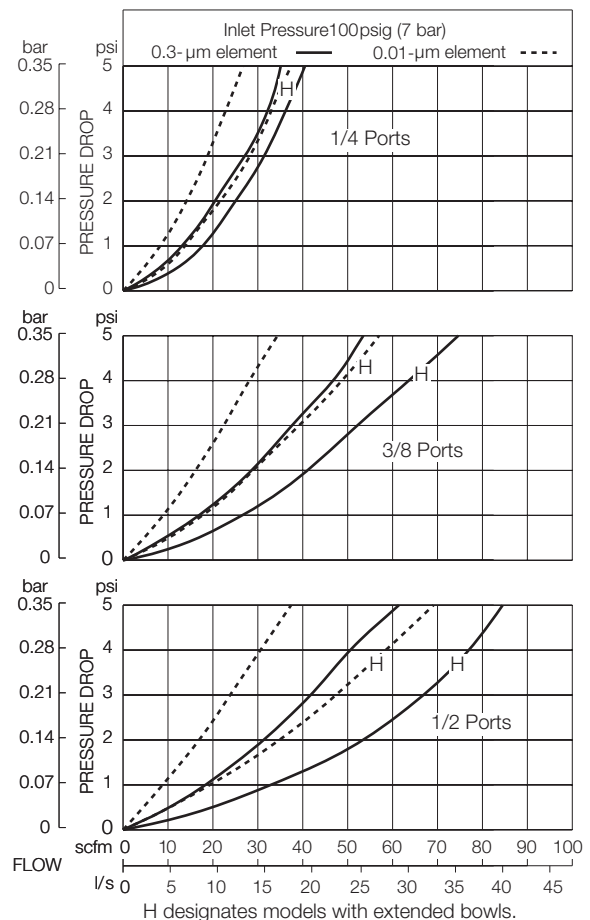

**APPLICATION NOTE:** A general purpose filter must be installed ahead of a coalescing filter to ensure good performance and to extend the life of the coalescing element.

**DIMENSIONS** inches (cm)

Bowl	A	B	C	Depth	Weight lb (kg)
Standard	2.7 (67)	5.9 (151)	1.8 (45)	2.4 (60)	1.75 (0.80)
Extended	2.7 (67)	8.9 (227)	1.8 (45)	2.4 (60)	2.00 (0.91)

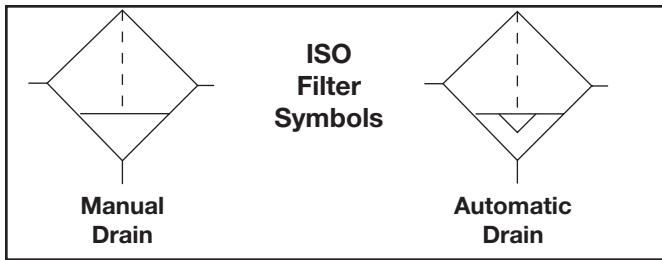
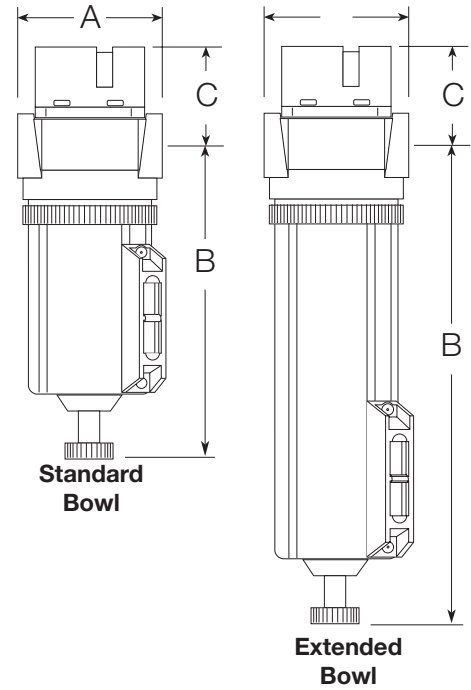

**REPLACEMENT FILTER ELEMENT KITS**

Element Type	Kit Number
0.3 μm Standard bowl (Std element).....	A60F-29
0.3 μm Extended bowl (Std element) .....	A60F-32
0.01 μm Standard bowl .....	A60F-29E8
0.01 μm Extended bowl.....	A60F-32E8

**ORDERING INFORMATION**

Change the letters in the sample model number below to specify the filter you want.

**B FCD 70 - 2 Y W**

**BOWL DRAIN**

Internal automatic drain ..... FCD  
Manual drain..... FC

**BOWL SIZE**

Standard 6-ounce bowl ..... 70  
Extended 10-ounce bowl ..... 70H  
with higher flow filter element

**PORT TYPE**

NPTF Threads ..... Leave Blank  
BSPP threads ..... W

**OPTIONS**

None ..... Leave Blank  
0.01-μm-rated element..... E8

**PORT SIZE**

1/4 NPTF..... 2  
3/8 NPTF..... 3  
1/2 NPTF..... 4  
9/16-18 UNF SAE ..... S6

# Full-Size VANGUARD Modular Coalescing Filters

# FC101 Models Port Sizes: 1/4, 3/8, 1/2



Model Shown: FC101-2

## SPECIFICATIONS

### Ambient/Media Temperature:

Plastic bowl: 40° to 125°F (4° to 52°C).  
Metal bowl: 40° to 175°F (4° to 79°C).

### Body:

**Bowl:** 8-Ounce (240-ml) capacity polycarbonate plastic with steel shatterguard; optional zinc bowl with clear nylon sight glass. Optional 20-ounce (600-ml) extended polycarbonate or zinc bowl has higher flow filter element.

**Bowl Drain:** Manual. Optional internal automatic drain only on extended aluminum bowl.

**Bowl Ring:** Aluminum.

**Differential Pressure Gauge:** Small K103-151.

**Filter Element:** 0.3- $\mu$ m-rated borosilicate-glass-fiber coalescing element; optional 0.01- $\mu$ m-rated element.

**Fluid Media:** Compressed air.

### Inlet Pressure:

15 psig (1 bar) minimum with automatic drain.  
Plastic Bowl: 150 psig (10 bar) maximum.  
Metal Bowl: 200 psig (14 bar) maximum.

**Seals:** Nitrile.

- ◆ Modular or inline mounting.
- ◆ 0.3- $\mu$ m-rated coalescing filter element; optional 0.01- $\mu$ m element.
- ◆ Differential pressure gauge.
- ◆ High-strength polycarbonate plastic filter bowl with steel shatterguard; optional metal bowl with clear nylon sight glass.
- ◆ Optional extended bowl with higher flow filter element.
- ◆ Manual filter drain; optional internal automatic drain with extended bowl.
- ◆ NPTF port threads; optional SAE or BSPP threads.

**APPLICATION NOTE:** A general purpose filter must be installed ahead of a coalescing filter to ensure good performance and to extend the life of the coalescing element.

## FLOW CHARTS

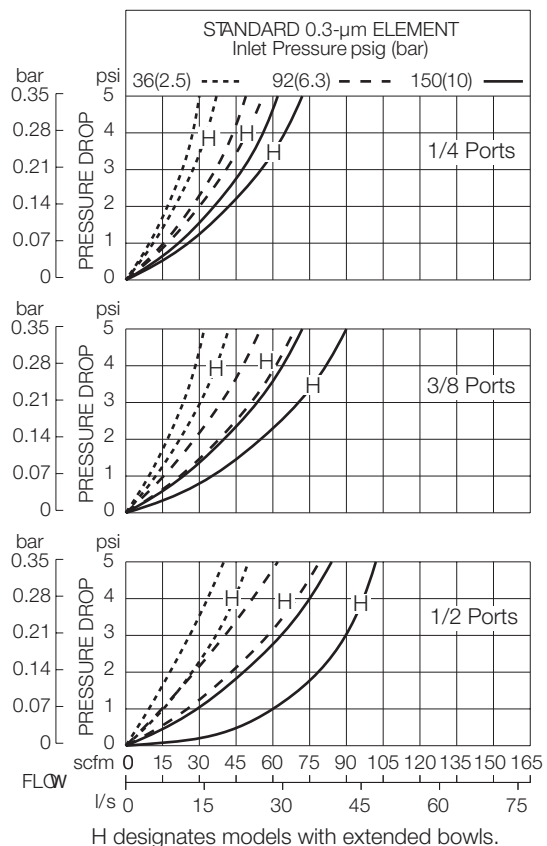



**DIMENSIONS** inches (mm)

Bowl	A	B	C	Depth	Weight lb (kg)
Standard	3.5 (89)	5.8 (146)	1.8 (45)	3.5 (89)	2.13 (0.95)
Extended	3.5 (89)	10.3 (260)	1.8 (45)	3.5 (89)	3.25 (1.54)

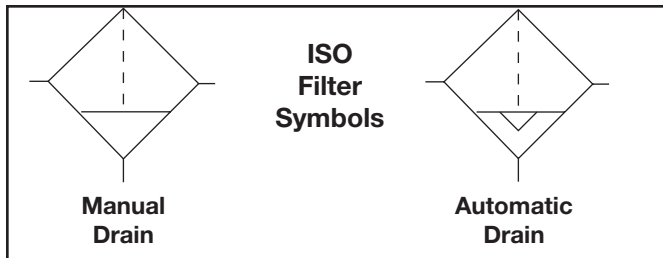
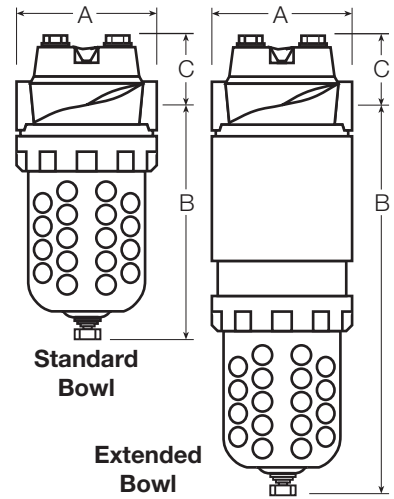

**REPLACEMENT FILTER ELEMENT KITS**

Element Type	Kit Number
0.3 µm Standard bowl (Std element).....	A103-160
0.3 µm Extended bowl .....	A103-160L
Models with E8 option:	
0.01 µm Standard bowl .....	A103-160E8
0.01 µm Extended bowl .....	A103-160LE8

**B** **FC** **101 - 2** **Y** **W**

**BOWL TYPE**  
 Plastic bowl ..... Leave blank  
 Metal bowl..... B

**BOWL DRAIN**  
 Manual drain..... FC  
 Internal automatic drain ..... FCD  
 (extended bowl only)

**BOWL SIZE & DIFFERENTIAL PRESSURE GAUGE**  
 Standard bowl & small gauge ..... 101  
 Standard bowl & large gauge..... 101L  
 Standard bowl & large gauge ..... 101E  
 with reed switch normally open  
 Standard bowl & large gauge ..... 101E2  
 with reed switch normally closed  
 Extended bowl & small gauge..... 101H  
 Extended bowl & large gauge ..... 101HL  
 Extended bowl & large gauge ..... 101HE  
 with reed switch normally open  
 Extended bowl & large gauge ..... 101E2  
 with reed switch normally closed

**PORT SIZE**  
 1/4 NPTF..... 2  
 3/8 NPTF..... 3  
 1/2 NPTF..... 4  
 9/16-18 UNF SAE ..... S6  
 3/4-16 UNF SAE ..... S8  
 7/8-14 UNF SAE ..... S10

**PORT TYPE**

NPTF Threads ..... Leave Blank  
 BSPP threads ..... W

**OPTIONS:** (More than one option can be chosen)

None..... Leave Blank  
 0.01-µm-rated element..... E8  
 Delete bowl drain; 1/4 NPT ..... LDC  
 female port instead  
 Delete differential pressure ..... NG

**DIFFERENTIAL PRESSURE GAUGES**



**Small Slide Gauge**  
K103-151



**Large Dual Face Gauge**  
106-35



**Large Dual Face Gauge with Reed Switch**  
 106-35E (Normally Open)  
 106-35EC (Normally Closed)

# Full-Size SERIES 380 Modular Coalescing Filters

# FCD380 Models Port Sizes: 3/8, 1/2, 3/4



Model Shown: FCD380S-4

## SPECIFICATIONS

### Ambient/Media Temperature:

Plastic bowl: 40° to 125°F (4° to 52°C).  
Metal bowl: 40° to 175°F (4° to 79°C).

**Body:** Die-cast zinc.

**Bowl:** 9-Ounce (270-ml) capacity polycarbonate plastic with steel shatterguard; optional aluminum bowl with clear nylon sight glass. Optional 15-ounce (450-ml) extended aluminum bowl with a clear nylon sight glass and higher flow filter element.

**Bowl Drain:** Internal automatic drain; optional manual drain or Warrior electronic drain.

**Bowl Ring:** Nylon.

**Cap Color:** Accent grey. Yellow, red, and blue optional.

**Differential Pressure Gauge:** Small K103-151.

**Filter Element:** 0.3- $\mu$ m-rated borosilicate-glass-fiber; optional 0.01- $\mu$ m-rated element (reduces flow by 20%).

**Fluid Media:** Compressed air.

### Inlet Pressure:

15 psig (1 bar) minimum with automatic drain.  
Plastic bowl: 150 psig (10 bar).  
Metal bowl: 200 psig (14 bar).

**Seals:** Nitrile.

- ◆ Modular or inline mounting.
- ◆ 0.3- $\mu$ m-rated coalescing filter element; optional 0.01- $\mu$ m-rated element.
- ◆ Polycarbonate plastic bowl with steel shatter-guard; optional metal bowl with sight glass.
- ◆ Optional extended metal bowl with higher capacity filter element included.
- ◆ Differential pressure gauge to indicate when filter element needs changing.
- ◆ Internal automatic bowl drain; optional manual drain or Warrior electronic drain.
- ◆ NPTF port threads; optional SAE or BSPP threads.

**APPLICATION NOTE:** A general purpose filter must be installed ahead of a coalescing filter to ensure good performance and to extend the life of the coalescing element.

## FLOW CHARTS

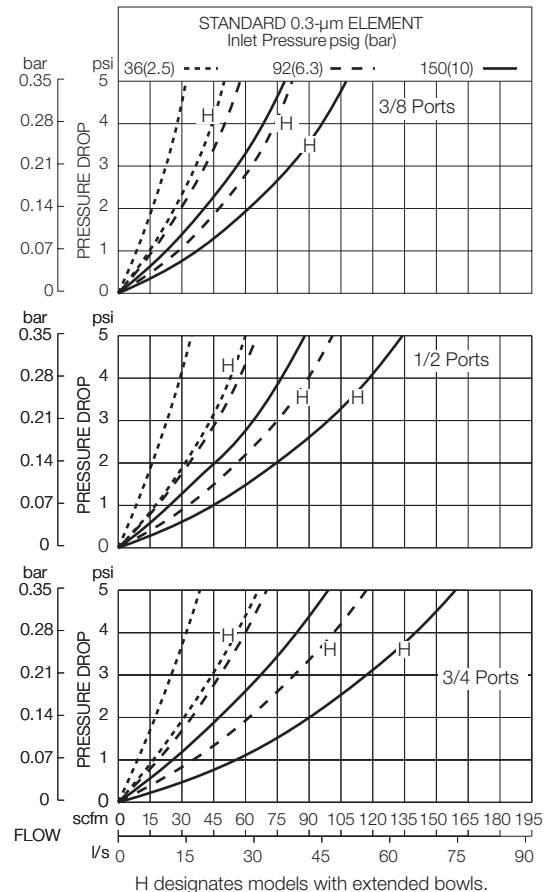

## DIMENSIONS inches (mm)

Bowl	A	B †	C	Depth	Weight lb (kg)
Polycarbonate	3.5 (88)	7.7 (195)	2.2 (55)	2.9 (73)	2.13 (0.97)
9-Ounce Metal	3.5 (88)	7.6 (193)	2.2 (55)	3.1 (79)	2.13 (0.97)
Extended Metal	3.5 (88)	11.2 (284)	2.2 (55)	3.1 (79)	2.31 (1.05)

† Bowl removal clearance: add 3.1 (79) for 9-ounce bowl; 6.1 (155) for extended bowl.

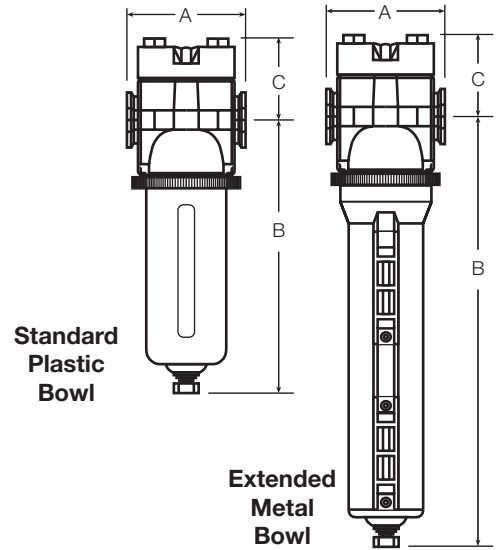
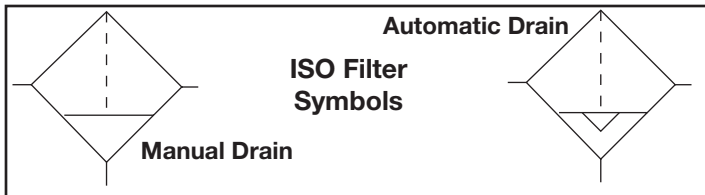
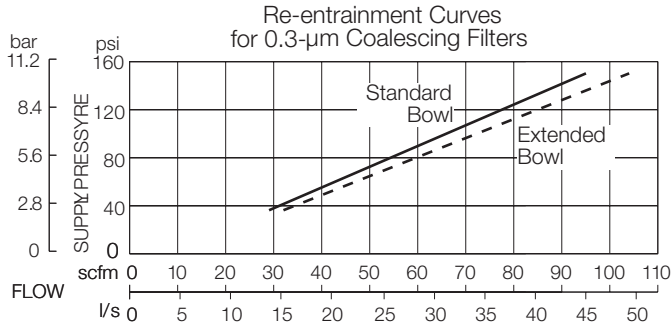

## REPLACEMENT FILTER ELEMENT KITS

Element Type	Kit Number
0.3 µm Standard bowl	A115-117
0.3 µm Extended bowl	A115-118
0.01 µm Standard bowl	A115-117E8
0.01 µm Extended bowl	A115-118E8

## ORDERING INFORMATION

Change the letters in the sample model number below to specify the filter you want.

### B FCD 380 S - 3 Y W

#### BOWL TYPE

Plastic with guard ..... Leave Blank  
Metal with sight glass ..... B

#### BOWL DRAIN

Internal automatic drain ..... FCD  
Manual drain ..... FC  
Warrior electronic drain; ..... FC2A  
only with metal bowl

#### BOWL SIZE

Standard 9-ounce ..... 380  
Extended 15-ounce high-flow .. 380H  
(metal bowl only)

#### DIFFERENTIAL PRESSURE GAUGE:

Delete gauge ..... Leave Blank  
Small gauge ..... S  
Large gauge ..... L  
Large gauge with reed switch ..... E  
normally open  
Reed switch large gauge ..... E2  
normally closed

#### PORT SIZE

3/8 NPTF ..... 3  
1/2 NPTF ..... 4  
3/4 NPTF ..... 6  
3/4-16 UNF SAE ..... S8  
7/8-14 UNF SAE ..... S10

#### PORT TYPE

NPTF Threads ..... Leave Blank  
BSP threads ..... W

#### OPTIONS: (More than one option can be chosen)

None ..... Leave Blank  
Cap color: Grey is standard.  
MP yellow ..... C1  
Red ..... C2  
Mid blue ..... C3  
0.01-µm-rated filter element ..... E8  
Delete bowl drain; 1/4 NPT ..... LDC  
female port instead (metal bowl only)

#### DIFFERENTIAL PRESSURE GAUGES



Small Slide Gauge  
K103-151



Large Dual Face Gauge  
106-35



Large Dual Face Gauge  
with Reed Switch  
106-35E (Normally Open)  
106-35EC (Normally Closed)

# High-Capacity VANGUARD Coalescing Filters

# FCD101 Models Port Sizes: 3/4, 1



Model Shown: FCD101-6

## SPECIFICATIONS

### Ambient/Media Temperature:

Plastic Bowl: 40° to 125°F (4° to 52°C).  
Metal Bowl: 40° to 175°F (4° to 79°C).

**Body:** Aluminum.

**Bowl:** 16-Ounce (480-ml) capacity polycarbonate plastic with steel shatterguard; optional aluminum bowl with clear nylon sight glass.

### Bowl Drain:

Internal automatic drain; optional manual drain.

**Bowl Ring:** Aluminum.

**Differential Pressure Gauge:** 106-35.

**Filter Element:** 0.3- $\mu$ m-rated borosilicate-glass-fiber coalescing element; optional 0.01- $\mu$ m-rated element.

**Fluid Media:** Compressed air.

### Inlet Pressure:

15 psig (1 bar) minimum with automatic drain.  
Plastic Bowl: 150 psig (10 bar) maximum.  
Metal Bowl: 200 psig (14 bar) maximum.

**Seals:** Nitrile.

- ◆ Inline mounting.
- ◆ 0.3- $\mu$ m-rated coalescing filter element; optional 0.01- $\mu$ m element.
- ◆ Differential pressure gauge.
- ◆ High-strength polycarbonate plastic filter bowl with steel shatterguard; optional aluminum bowl with clear nylon sight glass.
- ◆ Internal automatic drain; optional manual drain.
- ◆ **NPTF** port threads; optional **SAE** or **BSP** threads.

**APPLICATION NOTE:** A general purpose filter must be installed ahead of a coalescing filter to ensure good performance and to extend the life of the coalescing element.

## FLOW CHARTs

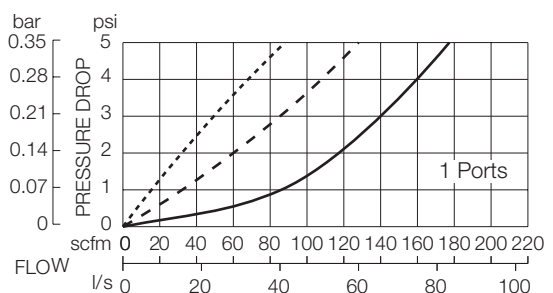
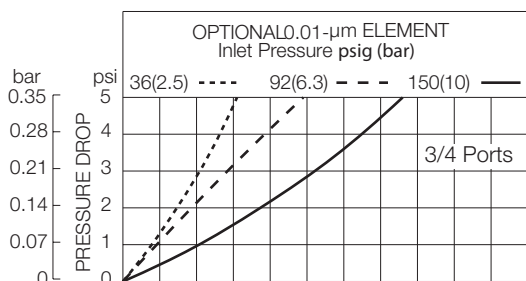
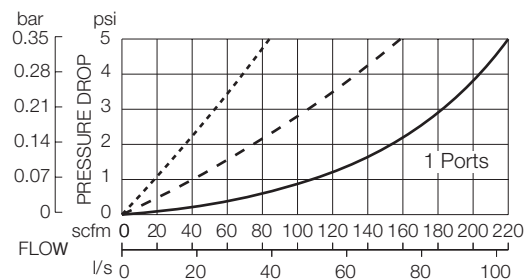
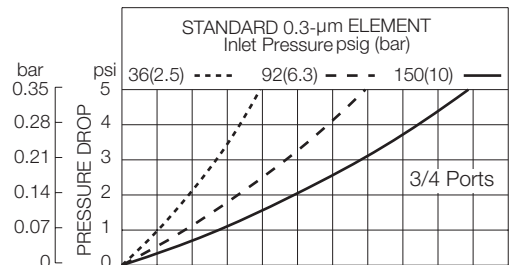

## DIMENSIONS inches (cm)

Bowl	A	B	C	Depth	Weight lb (kg)
Plastic	4.5 (114)	8.0 (203)	3.1 (78)	4.5 (114)	2.38 (1.09)
Metal	4.5 (114)	8.3 (210)	3.1 (78)	4.5 (114)	3.20 (1.46)

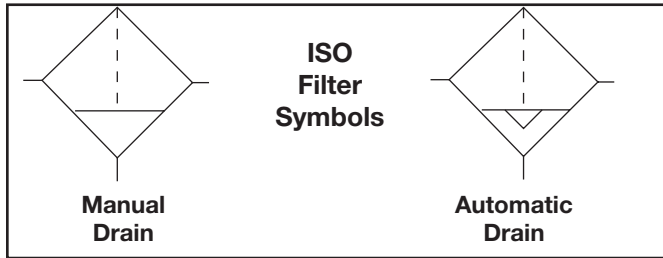
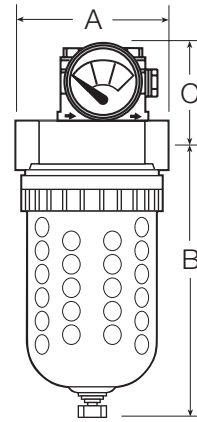

## REPLACEMENT FILTER ELEMENT KITS

Element Rating	Kit Number
0.3 µm (Std element)	A109-106
0.01 µm	
For models with E8 option	A109-106E8

## ORDERING INFORMATION

Change the letters in the sample model number below to specify the filter you want.

**B FCD 101 - 6 Y W**

### BOWL TYPE

Plastic bowl ..... Leave blank  
Metal bowl ..... B

### BOWL DRAIN

Internal automatic drain ..... FCD  
Manual drain ..... FC

### DIFFERENTIAL PRESSURE GAUGE

Standard large 106-35 gauge ..... 101  
Small K103-151 gauge ..... 101S  
Large gauge with reed switch ..... 101E  
normally open  
Large gauge with reed switch ..... 101E2  
normally closed

### PORT TYPE

NPTF Threads ..... Leave Blank  
BSPP threads ..... W

### OPTIONS: (More than one option can be chosen)

None ..... Leave Blank  
0.01-µm-rated element ..... E8  
Delete bowl drain; 1/4 NPT .... LDC  
female port instead  
Delete differential pressure ..... NG  
gauge

### PORT SIZE

3/4 NPTF ..... 6  
1 NPTF ..... 8  
1-1/16-12 UNF SAE ..... S12  
1-5/16-12 UNF SAE ..... S16

## DIFFERENTIAL PRESSURE GAUGES



Small Slide Gauge  
K103-151



Large Dual Face Gauge  
106-35



Large Dual Face Gauge  
with Reed Switch  
106-35E (Normally Open)  
106-35EC (Normally Closed)

# High-Capacity VANGUARD Coalescing Filters

# BFCD101 Models Port Sizes: 1-1/4, 1-1/2



Model Shown: BFCD101-10

## SPECIFICATIONS

### Ambient/Media Temperature:

40° to 175°F (4° to 79°C).

### Body: Aluminum.

**Bowl:** 123-Ounce (3.7-liter) capacity aluminum bowl. Optional 233-ounce (7-liter) extended aluminum bowl has higher flow filter element.

### Bowl Drain:

Internal automatic drain; optional manual drain.

### Differential Pressure Gauge: 106-35.

**Filter Element:** 0.3- $\mu\text{m}$ -rated borosilicate-glass-fiber coalescing element; optional 0.01- $\mu\text{m}$ -rated element.

**Fluid Media:** Compressed air.

### Inlet Pressure:

15 psig (1 bar) minimum with automatic drain.  
200 psig (14 bar) maximum.

**Seals:** Nitrile.

**V-Band:** Stainless steel.

- ◆ Inline mounting.
- ◆ 0.3- $\mu\text{m}$ -rated coalescing filter element; optional 0.01- $\mu\text{m}$  element.
- ◆ Differential pressure gauge.
- ◆ Metal bowl.
- ◆ Optional extended bowl with higher capacity filter element for greater air flow.
- ◆ Internal automatic drain; optional manual drain.
- ◆ NPTF port threads; optional SAE or BSPP threads.

**APPLICATION NOTE:** A general purpose filter must be installed ahead of a coalescing filter to ensure good performance and to extend the life of the coalescing element.

## FLOW CHARTS

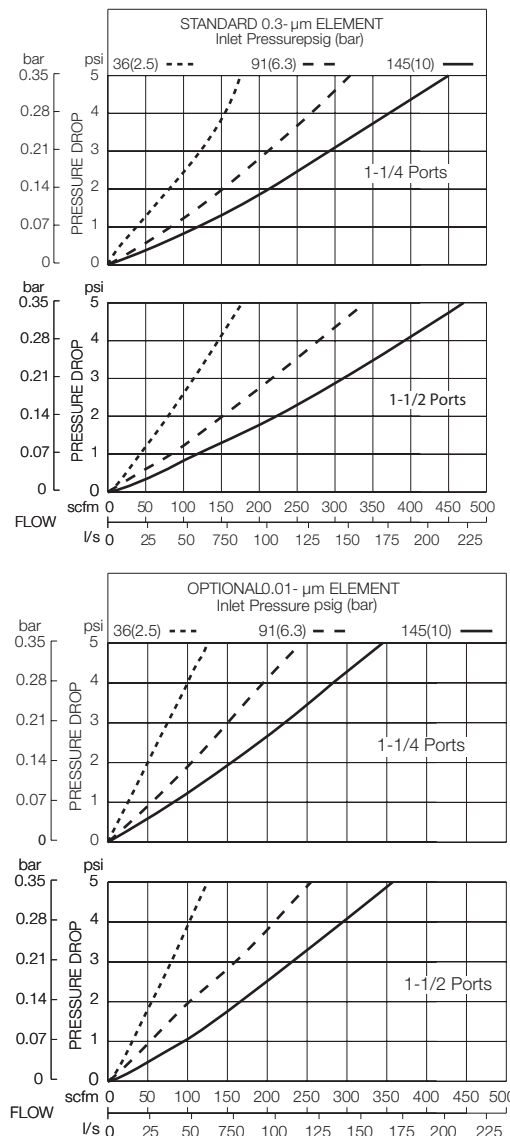

**DIMENSIONS** inches (mm)

Bowl	A	B	C	Depth	Weight lb (kg)
Standard	7.8 (197)	15 (381)	3.9 (99)	7.8 (197)	14.6 (6.6)
Extended	7.8 (197)	22 (559)	3.9 (99)	7.8 (197)	19.7 (8.9)

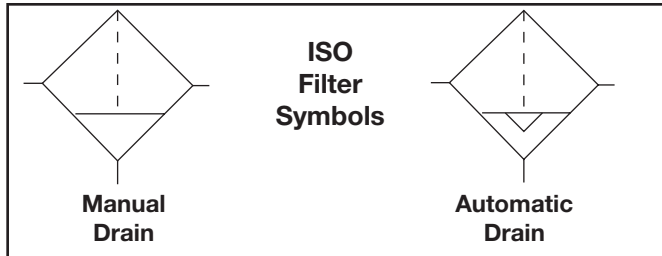
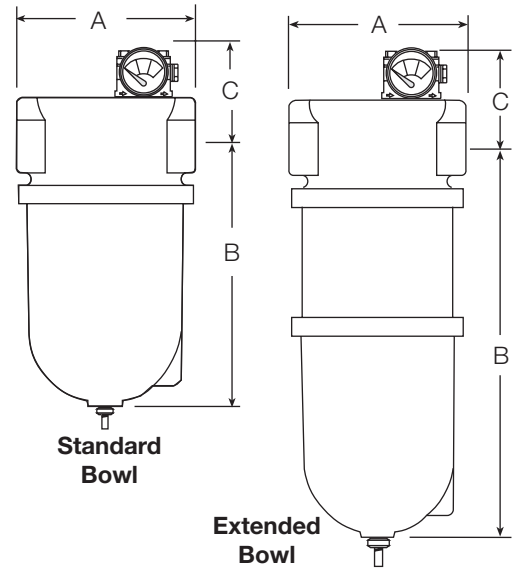

**REPLACEMENT FILTER ELEMENT KITS**

Element Type	Kit Number
0.3 µm Standard bowl (Std element)	A106-24
0.3 µm Extended bowl	A106-24L
Models with E8 option:	
0.01 µm Standard bowl	A106-24E8
0.01 µm Extended bowl	A106-24LE8

**ORDERING INFORMATION**

Change the letters in the sample model number below to specify the filter you want.

**B F C D 101 - 10 Y W**

**BOWL DRAIN**

Internal automatic drain .....BFCD  
Manual drain.....BFC

**BOWL SIZE & DIFFERENTIAL PRESSURE GAUGE**

Standard bowl & large gauge..... 101  
Standard bowl & small gauge ..... 101S  
Standard bowl & large gauge with .... 101E  
normally open reed switch  
Standard bowl & large gauge with .... 101E2  
normally closed reed switch  
Extended bowl & large gauge ..... 101H  
Extended bowl & small gauge..... 101HS  
Extended bowl & large gauge with .... 101HE  
normally open reed switch  
Extended bowl & large gauge with .... 101HE2  
normally closed reed switch

**PORT SIZE**

1-1/4 NPTF ..... 10  
1-1/2 NPTF ..... 12  
1-5/8-12 UNF SAE ..... S20  
1-7/8-12 UNF SAE ..... S24

**PORT TYPE**

NPTF Threads ..... Leave Blank  
BSP threads ..... W

**OPTIONS:** (More than one option can be chosen)

None..... Leave Blank  
0.01-µm-rated element..... E8  
Delete bowl drain; 1/4 NPT ..... LDC  
female port instead  
Delete differential pressure ..... NG  
gauge

**DIFFERENTIAL PRESSURE GAUGES**

**Small Slide Gauge**  
K103-151



**Large Dual Face Gauge**  
106-35



**Large Dual Face Gauge with Reed Switch**  
106-35E (Normally Open)  
106-35EC (Normally Closed)



Coalescing FILTERS

# High-Capacity VANGUARD Coalescing Filters

## BFCD101 Model Port Size: 2



Model Shown: BFCD101-16

- ◆ Inline mounting.
- ◆ 0.3- $\mu\text{m}$ -rated coalescing filter element; optional 0.01- $\mu\text{m}$  element.
- ◆ Differential pressure gauge.
- ◆ Metal bowl.
- ◆ Internal automatic drain; optional manual drain.
- ◆ NPTF port threads; optional SAE or BSPP threads.

**APPLICATION NOTE:** A general purpose filter must be installed ahead of a coalescing filter to ensure good performance and to extend the life of the coalescing element.

### SPECIFICATIONS

**Ambient/Media Temperature:**

40° to 175°F (4° to 79°C).

**Body:** Aluminum.

**Bowl:** 233-Ounce (7-liter) capacity aluminum bowl.

**Bowl Drain:**

Internal automatic drain; optional manual drain.

**Differential Pressure Gauge:** Large 106-35.

**Filter Element:** 0.3- $\mu\text{m}$ -rated borosilicate-glass-fiber coalescing element; optional 0.01- $\mu\text{m}$ -rated element.

**Fluid Media:** Compressed air.

**Inlet Pressure:**

15 psig (1 bar) minimum with automatic drain.  
200 psig (14 bar) maximum.

**Seals:** Nitrile.

**V-Band:** Stainless steel.

### FLOW CHARTS

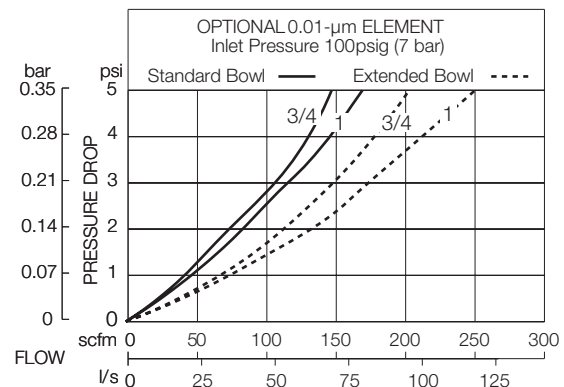
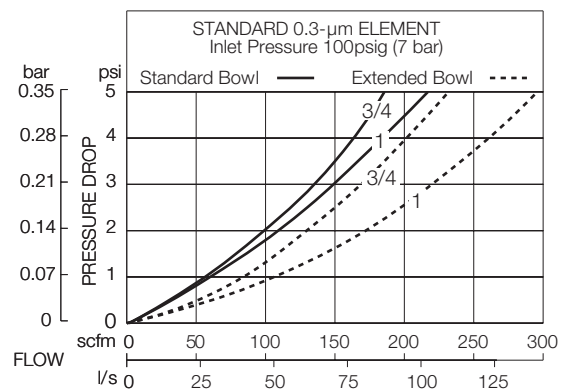



**DIMENSIONS** inches (cm)

A	B	C	Depth	Weight lb (kg)
7.8 (197)	22 (559)	3.9 (99)	7.8 (197)	19.7 (8.9)

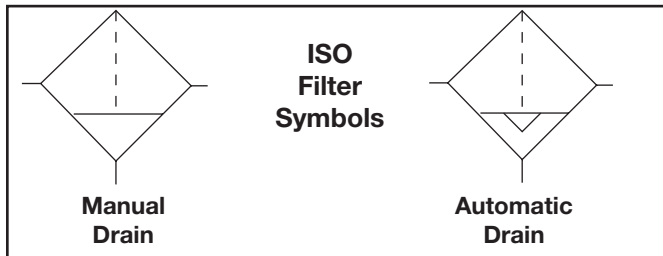
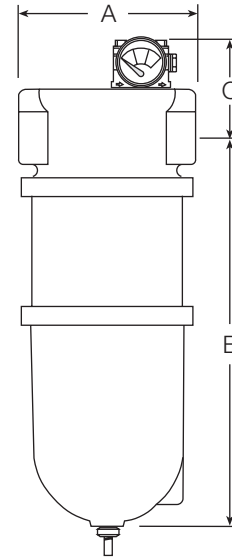

**REPLACEMENT FILTER ELEMENT KITS**

Element Rating	Kit Number
0.3 µm (Std element)	A106-24L
0.01 µm For model with E8 option	A106-24LE8

**ORDERING INFORMATION**

Change the letters in the sample model number below to specify the filter you want.

**BFCD 101 - 16 Y W**

**BOWL DRAIN**

- Internal automatic drain .....BFCD
- Manual drain.....BFC

**DIFFERENTIAL PRESSURE GAUGE**

- Large gauge ..... 101
- Large gauge with normally ..... 101E  
open reed switch
- Large gauge with normally ..... 101E2  
closed reed switch
- Small gauge ..... 101S

**PORT TYPE**

- NPTF Threads ..... Leave Blank
- BSPF threads ..... W

**OPTIONS:** *(More than one option can be chosen)*

- None..... Leave Blank
- 0.01-µm-rated element..... E8
- Delete bowl drain; 1/4 NPT ..... LDC  
female port instead
- Delete differential pressure ..... NG  
gauge

**PORT SIZE**

- 2 NPTF ..... 16
- 1-5/8-12 UNF SAE ..... S20
- 1-7/8-12 UNF SAE ..... S24
- 2-1/2-12 UNF SAE ..... S32

**DIFFERENTIAL PRESSURE GAUGES**



Small Slide Gauge  
K103-151



Large Dual Face Gauge  
106-35



Large Dual Face Gauge  
with Reed Switch  
106-35E (Normally Open)  
106-35EC (Normally Closed)

# High-Capacity VANGUARD Coalescing Filters

# BFCD201 Models Port Sizes: 3/4, 1



Model Shown: BFCD201-6

- ◆ Inline mounting.
- ◆ 0.3- $\mu\text{m}$ -rated coalescing filter element; optional 0.01- $\mu\text{m}$  element.
- ◆ Differential pressure gauge.
- ◆ Aluminum bowl.
- ◆ Internal automatic drain; optional manual drain.
- ◆ NPTF port threads; optional SAE or BSPP threads.

**APPLICATION NOTE:** A general purpose filter must be installed ahead of a coalescing filter to ensure good performance and to extend the life of the coalescing element.

## SPECIFICATIONS

**Ambient/Media Temperature:**

40° to 175°F (4° to 79°C).

**Body:** Aluminum.

**Bowl:** 35-Ounce (1050-ml) capacity aluminum bowl. Optional 62-ounce (1860-ml) extended aluminum bowl has higher capacity filter element for increased air flow.

**Bowl Drain:**

Internal automatic drain; optional manual drain.

**Bowl Ring:** Aluminum.

**Differential Pressure Gauge:** Large 106-35.

**Filter Element:** 0.3- $\mu\text{m}$ -rated borosilicate-glass-fiber coalescing element; optional 0.01- $\mu\text{m}$ -rated element.

**Fluid Media:** Compressed air.

**Inlet Pressure:**

15 psig (1 bar) minimum with automatic drain. 200 psig (14 bar) maximum.

**Seals:** Nitrile.

## FLOW CHARTS

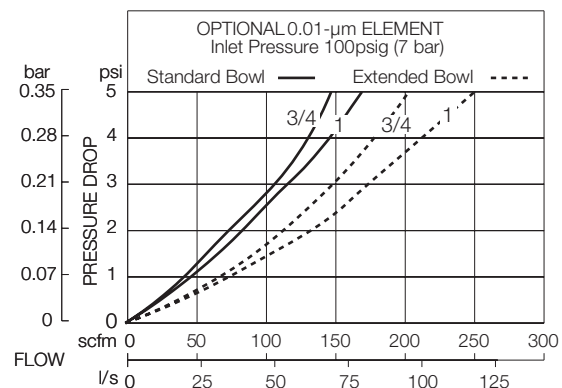
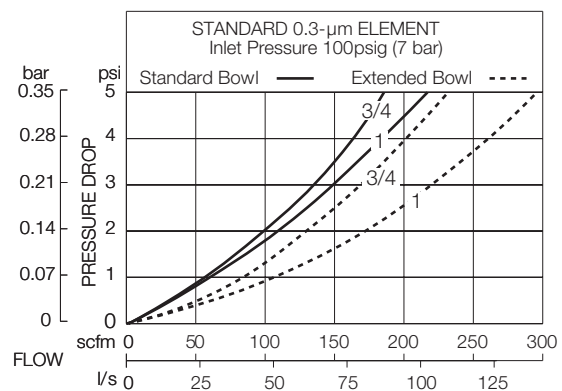

**DIMENSIONS** inches (mm)

Bowl	A	B	C	Depth	Weight lb (kg)
Standard	4.5 (114)	10.1 (257)	3.3 (83)	4.2 (106)	3.50 (1.59)
Extended	4.5 (114)	15.7 (399)	3.3 (83)	4.2 (106)	4.25 (1.91)

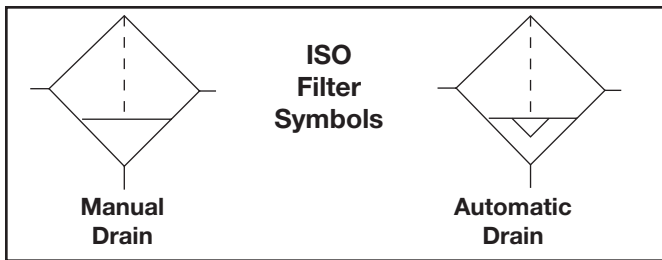
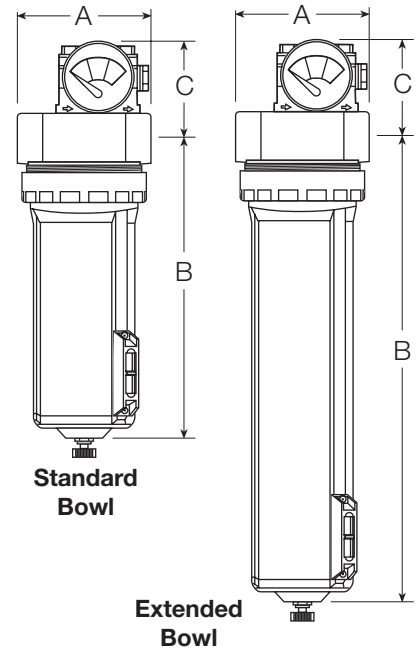

**REPLACEMENT FILTER ELEMENT KITS**

Model	Element Rating	Kit Number
Standard bowl	0.3- $\mu$ m (Std element)	A114-112
With E8 option	0.01- $\mu$ m	A114-112E8
Extended bowl	0.3- $\mu$ m	A114-113
With E8 option	0.01- $\mu$ m	A114-113E8

**ORDERING INFORMATION**

Change the letters in the sample model number below to specify the filter you want.

**B F C D 201 - 6 Y W**

**BOWL DRAIN**

Internal automatic drain .....B F C D  
Manual drain.....B F C

**BOWL SIZE & DIFFERENTIAL PRESSURE GAUGE**

Standard bowl & large gauge..... 201  
Standard bowl & small gauge .... 201S  
Standard bowl & large gauge with ... 201E  
normally open reed switch  
Standard bowl & large gauge with ... 201E2  
normally closed reed switch  
Extended bowl & large gauge ..... 201H  
Extended bowl & small gauge. .... 201HS  
Extended bowl & large gauge with ... 201HE  
normally open reed switch  
Extended bowl & large gauge with ... 201HE2  
normally closed reed switch

**PORT SIZE**

3/4 NPTF..... 6  
1 NPTF..... 8  
1-1/16-12 UNF SAE ..... S12  
1-5/16-12 UNF SAE ..... S16

**PORT TYPE**

NPTF Threads ..... Leave Blank  
BSP threads ..... W

**OPTIONS:** (More than one option can be chosen)

None ..... Leave Blank  
0.01- $\mu$ m-rated element..... E8  
Delete bowl drain; 1/4 NPT ..... LDC  
female port instead  
Delete differential pressure ..... NG gauge

**DIFFERENTIAL PRESSURE GAUGES**



Small Slide Gauge  
K103-151



Large Dual Face Gauge  
106-35



Large Dual Face Gauge  
with Reed Switch  
106-35E (Normally Open)  
106-35EC (Normally Closed)

# High-Capacity VANGUARD Coalescing Filters

# BFCD201 Models Port Sizes: 1-1/4, 1-1/2

Model Shown: BFCD201-10



- ◆ Inline mounting.
- ◆ 0.3- $\mu\text{m}$ -rated coalescing filter element; optional 0.01- $\mu\text{m}$  element.
- ◆ Differential pressure gauge.
- ◆ Aluminum bowl. Optional extended bowl with higher flow element.
- ◆ Internal automatic drain; optional manual drain.
- ◆ NPTF port threads; optional SAE or BSPP threads.

**APPLICATION NOTE:** A general purpose filter must be installed ahead of a coalescing filter to ensure good performance and to extend the life of the coalescing element.

## SPECIFICATIONS

**Ambient/Media Temperature:**

40° to 175°F (4° to 79°C).

**Body:** Aluminum.

**Bowl:** 35-Ounce (1050-ml) capacity aluminum bowl. Optional 62-ounce (1860-ml) extended aluminum bowl has higher capacity filter element for increased air flow.

**Bowl Drain:**

Internal automatic drain; optional manual drain.

**Bowl Ring:** Aluminum.

**Differential Pressure Gauge:** Large 106-35.

**Filter Element:** 0.3- $\mu\text{m}$ -rated borosilicate-glass-fiber coalescing element; optional 0.01- $\mu\text{m}$ -rated element.

**Fluid Media:** Compressed air.

**Inlet Pressure:**

15 psig (1 bar) minimum with automatic drain.  
200 psig (14 bar) maximum.

**Seals:** Nitrile.

## FLOW CHARTS

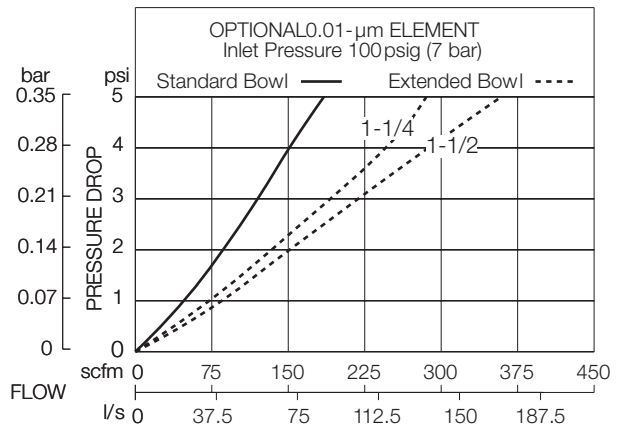
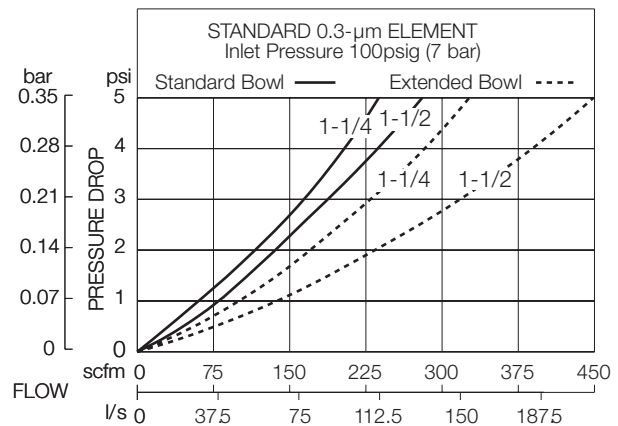

## DIMENSIONS inches (mm)

Bowl	A	B	C	Depth	Weight lb (kg)
Standard	5.5 (140)	10.6 (270)	3.7 (94)	4.2 (106)	4.31 (1.94)
Extended	5.5 (140)	16.2 (412)	3.7 (94)	4.2 (106)	5.00 (2.27)

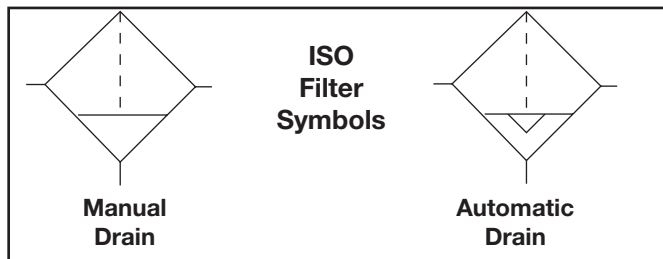
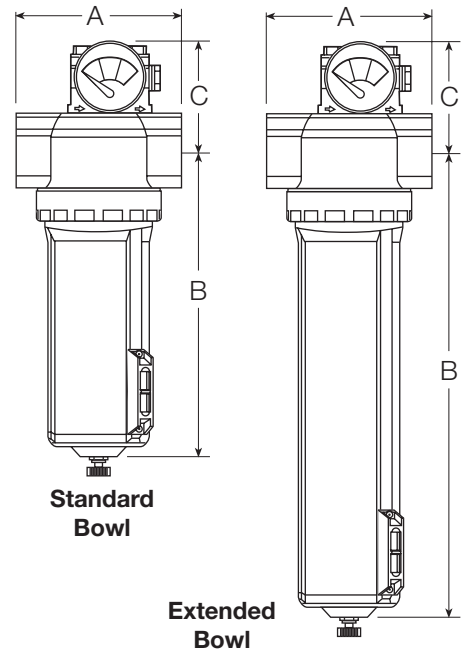

## REPLACEMENT FILTER ELEMENT KITS

Element Type	Kit Number
0.3 µm Standard bowl (Std element)	A114-112
0.3 µm Extended bowl	A114-113
Models with E8 option:	
0.01 µm Standard bowl	A114-112E8
0.01 µm Extended bowl	A114-113E8

## ORDERING INFORMATION

Change the letters in the sample model number below to specify the filter you want.

**BFC D 201 - 10 Y W**

### BOWL DRAIN

Internal automatic drain .....BFC D  
Manual drain.....BFC

### BOWL SIZE & DIFFERENTIAL PRESSURE GAUGE

Standard bowl & large gauge.....201  
Standard bowl & small gauge ..... 201S  
Standard bowl & large gauge ..... 201E  
with normally open reed switch  
Standard bowl & large gauge ..... 201E2  
with normally closed reed switch  
Extended bowl & large gauge .....201H  
Extended bowl & small gauge..... 201HS  
Extended bowl & large gauge ..... 201HE  
with normally open reed switch  
Extended bowl & large gauge ..... 201HE2  
with normally closed reed switch

### PORT SIZE

1-1/4 NPTF ..... 10  
1-1/2 NPTF ..... 12  
1-5/8-12 UNF SAE ..... S20  
1-7/8-12 UNF SAE ..... S24

### PORT TYPE

NPTF Threads ..... Leave Blank  
BSP threads ..... W

**OPTIONS:** (More than one option can be chosen)

None ..... Leave Blank  
0.01-µm-rated element..... E8  
Delete bowl drain; 1/4 NPT..... LDC  
female port instead  
Delete differential pressure..... NG  
gauge

### DIFFERENTIAL PRESSURE GAUGES



Small Slide Gauge  
K103-151



Large Dual Face Gauge  
106-35



Large Dual Face Gauge  
with Reed Switch  
106-35E (Normally Open)  
106-35EC (Normally Closed)

# ADSORBING FILTERS, DRYERS, CLEAN AIR PACKAGES

## OIL REMOVAL ADSORBING FILTERS



The adsorbing filters are designed to remove vapors from the air line that cannot be removed by a coalescing filter. They produce air that is virtually free of oil and hydrocarbons as required by industries such as food processing, electronics, and instrumentation.

The filter cartridges contain activated carbon to adsorb hydrocarbon vapors and odors from alcohols, esters, and ketones. An optional extended bowl includes a higher capacity adsorbing cartridge which allows as much as 50 percent greater air flow.

Series **BFC70-E9** adsorbing filters have aluminum bowls and are offered with 1/4, 3/8, or 1/2 ports. Series **FC380-E9** units have either polycarbonate plastic or aluminum bowls and are offered with 3/8, 1/2, or 3/4 ports.

An adsorbing filter should always be preceded by a particulate filter and a coalescing filter. Such an assembly is one of Master Pneumatic's Clean Air Packages which will provide air with no more oil than 10 mg/m<sup>3</sup> or 0.008 ppm.

## CLEAN AIR PACKAGES



In critical applications when vapor impurities are a potential problem, the installation of a Clean Air Package provides the solution. Ultra clean air is provided by using the particulate filters as the first line of defense against gross contaminants found in all air lines. Elements remove

solid particles larger than 5 micron, while automatic drains eliminate liquid water and oil emulsions that collect in the sump area. The particulate filter serves as a pre-filter to extend the life of the more costly coalescing element used for the next stage of filtration.

The coalescing filter element will further clean the air of residual oil mists, aerosols, and minute particles, larger than 0.3 micron. A standard differential pressure gauge warns when the pressure drop exceeds 8 to 10 psi, indicating that the coalescing element should be changed.

Finally, the adsorber filter will provide air, virtually free of oil and most hydrocarbons. It effectively eliminates odors from freons, alcohols, esters, ketones, and up to 99% of most hydrocarbons in breathing applications.

Clean Air Packages are available with port sizes ranging from 1/4 to 3/4.

## MP-FILENCO DRYER/FILTERS



Many compressed air systems require point-of-use cleaning and drying of the air to supplement a central system. Dryer/filters do this extremely well because of their triple-action cleaning process and their ability to substantially reduce pressure dew points.

Available desiccants for these units include clay, clay with activated carbon, and molecular sieves for as much as 80° dew point suppression.

Automatic drains are strongly recommended, although there are a variety of options offered — from simple manual drains to the Warrior electronic drain.

# MP-FILENCO DRYER CROSS SECTION

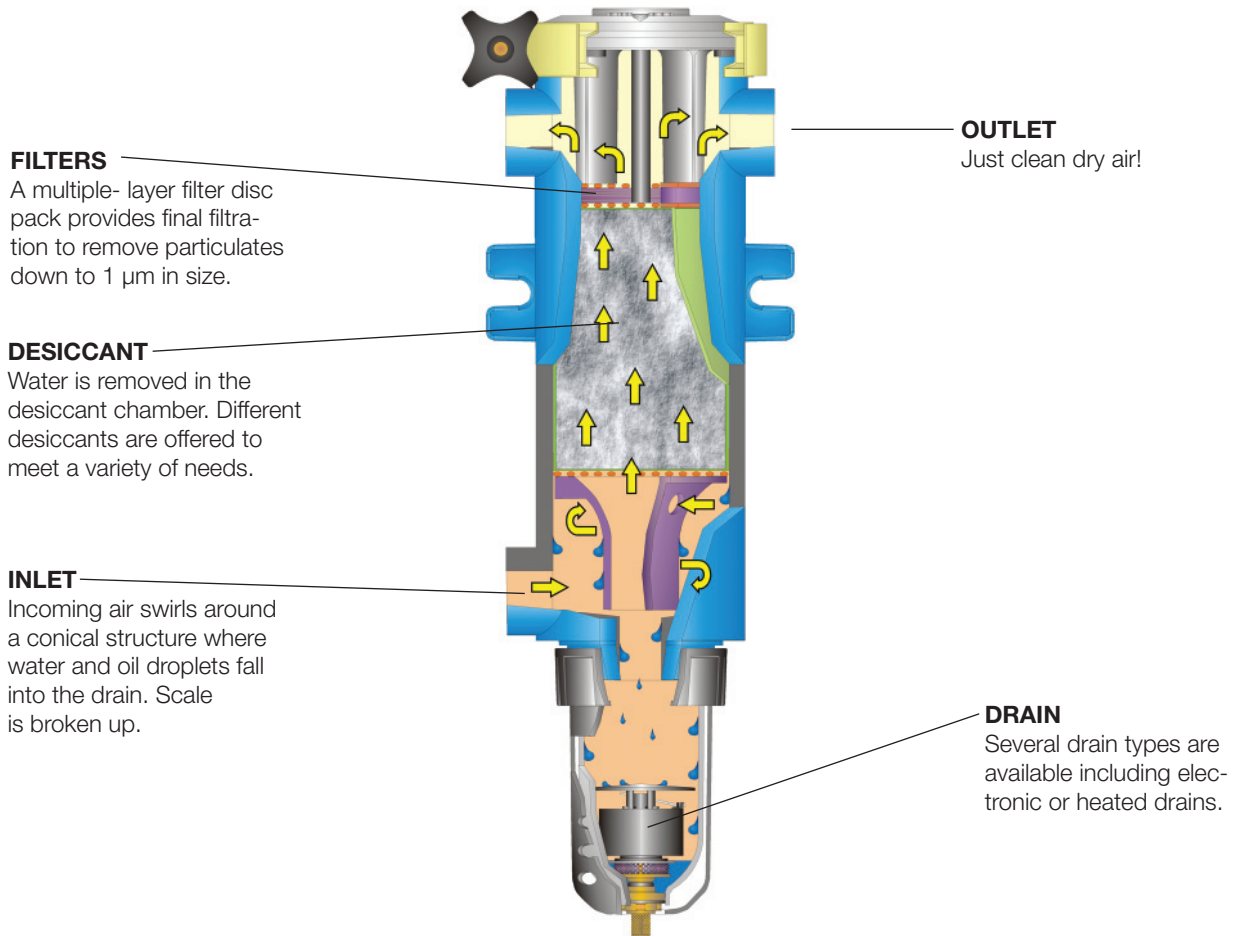

## GUIDE to ADSORBING FILTERS, DRYERS and CLEAN AIR PACKAGES

Product	Port Sizes							Pages
	1/4	3/8	1/2	3/4	1	1-1/2	2	
<b>ADSORBING FILTERS</b>								
BFC70-E9	X	X	X					96-97
FC380-E9		X	X	X				98-99
<b>CLEAN AIR PACKAGES</b>								
Guardzman II	X	X	X					100-101
Series 380		X	X	X				102-103
<b>MP-FILENCO DRYER/FILTERS</b>								
Series 25	X							104-105
Series 36		X						106-107
Series 38			X					106-107
Series 418					X			108-109
Series 625						X		110-111
Series 832							X	110-111

# GUARDSMAN II Modular Oil Vapor Removal (Adsorbing) Filters

# BFC70-E9 Models Port Sizes: 1/4, 3/8, 1/2



Model Shown: BFC70-4E9

## SPECIFICATIONS

**Ambient/Media Temperature:**

40° to 175°F (4° to 79°C).

**Body:** Zinc.

**Bowl:** 6-Ounce (180-ml) capacity aluminum. Optional 10-ounce (300-ml) extended aluminum bowl has higher flow filter cartridge.

**Bowl Drain:** Manual.

**Bowl Ring:** Nylon.

**Filter Cartridge:** Activated carbon.

**Fluid Media:** Compressed air.

**Inlet Pressure:** 200 psig (14 bar) maximum.

**Seals:** Nitrile.

The adsorbing filter is designed to remove vapors from the air line that cannot be removed by a coalescing filter. It produces air virtually free of oil and hydrocarbons as required by industries such as food processing, electronics, and instrumentation.

An adsorbing filter must be preceded by a coalescing filter, and these filters should be preceded by a general purpose filter. Such a trio of filters constitutes a Clean Air Package that will provide air with no more than 0.01 mg of oil per cubic meter. For such clean air assemblies see following pages.

- ◆ Modular or inline mounting.
- ◆ Filter cartridge contains activated carbon
- ◆ Aluminum bowl. Optional extended bowl with higher flow cartridge.
- ◆ Manual drain.
- ◆ **NPTF** port threads; optional **SAE** or **BSPP** threads.

## FLOW CHARTS

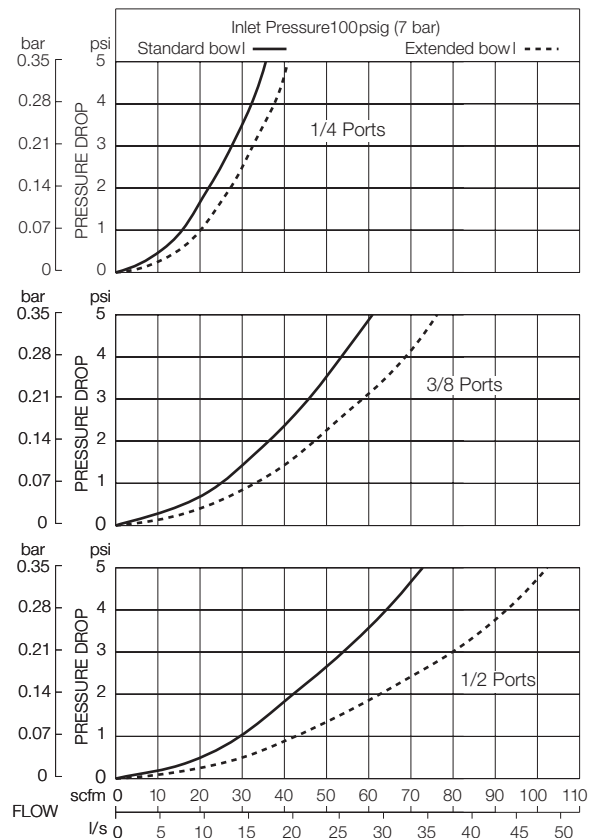



**DIMENSIONS** inches (mm)

Bowl	A	B	C	Depth	Weight lb (kg)
Standard	2.7 (67)	5.9 (151)	0.63 (16)	2.4 (60)	1.50 (0.68)
Extended	2.7 (67)	8.9 (227)	0.63 (16)	2.4 (60)	1.75 (0.80)

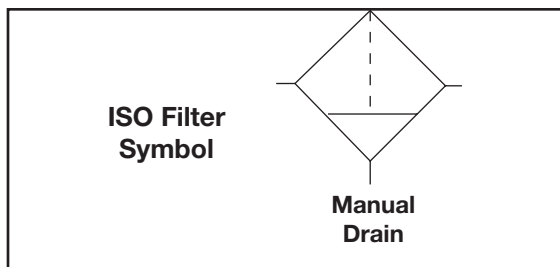
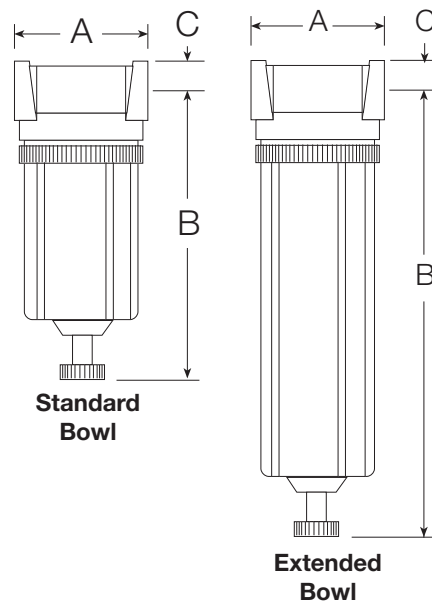

**REPLACEMENT FILTER ELEMENT KITS**

Bowl	Kit Number
Standard (Std cartridge) .....	A60F-29E9
Extended.....	A60F-32E9

**ORDERING INFORMATION**

Change the letters in the sample model number below to specify the filter you want.

**BFC 70 - 2 E9 W**

**BOWL SIZE**

- Standard 6-ounce bowl ..... 70
- Extended 10-ounce bowl ..... 70H  
with higher flow filter cartridge

**PORT TYPE**

- NPTF Threads ..... Leave Blank
- BSPP threads ..... W

**PORT SIZE**

- 1/4 NPTF..... 2
- 3/8 NPTF..... 3
- 1/2 NPFT..... 4
- 9/16-18 UNF SAE ..... S6

# Full-Size SERIES 380 Modular Oil Vapor Removal (Adsorbing) Filters

# FC380-E9 Models Port Sizes: 3/8, 1/2, 3/4

The adsorbing filter is designed to remove vapors from the air line that cannot be removed by a coalescing filter. It produces air free of oil and hydrocarbons as required by industries such as food processing, electronics, and instrumentation. An adsorbing filter preceded by a coalescing filter and a general purpose filter constitute a Clean Air Package as shown on the following pages.

### Available Color Caps

**Yellow**  
(optional)



**Red**  
(optional)



**Blue**  
(optional)



**Grey**  
(standard)



Model Shown: FC380-6E9

### SPECIFICATIONS

#### Ambient/Media Temperature:

Plastic bowl: 40° to 125°F (4° to 52°C).

Metal bowl: 40° to 175°F (4° to 79°C).

**Body:** Zinc.

**Bowl:** 9-Ounce (270-ml) capacity polycarbonate plastic with steel shatterguard; optional aluminum bowl.

Optional 15-ounce (450-ml) extended aluminum bowl includes a higher capacity adsorbing cartridge.

**Bowl Drain:** Manual.

**Bowl Ring:** Nylon.

**Cap Color:** Accent grey. Yellow, red, and blue optional.

**Filter Cartridge:** Activated carbon with urethane seals.

**Fluid Media:** Compressed air.

#### Inlet Pressure:

Plastic bowl: 150 psig (10 bar) maximum.

Metal bowl: 200 psig (14 bar) maximum.

**Seals:** Nitrile.

- ◆ Modular or inline mounting.
- ◆ Filter cartridge contains activated carbon.
- ◆ Polycarbonate plastic bowl with steel shatter-guard; optional aluminum bowl. Optional extended aluminum bowl with higher flow filter cartridge.
- ◆ Manual drain.
- ◆ NPTF port threads; optional SAE or BSPP threads.

### FLOW CHARTS

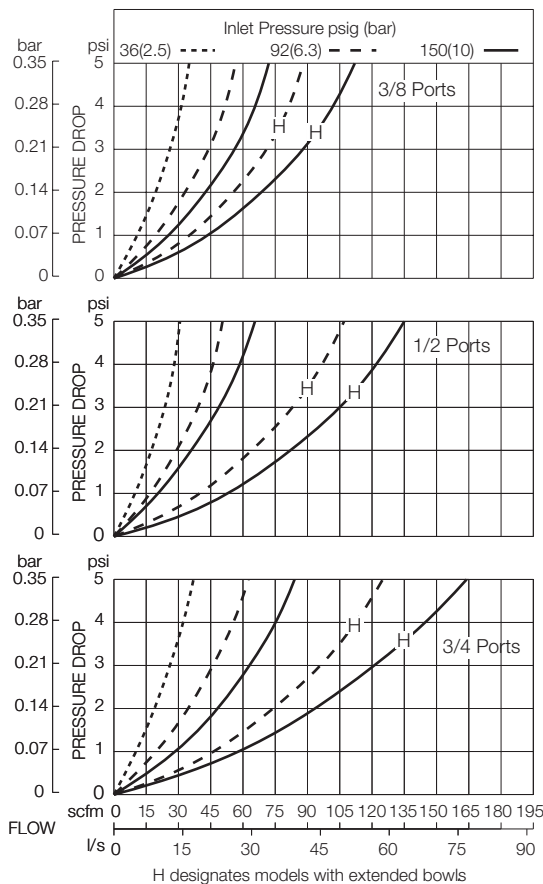

**DIMENSIONS** inches (mm)

Bowl	A	B †	C	Depth	Weight lb (kg)
Polycarbonate	3.5 (88)	7.7 (195)	1.1 (28)	2.9 (73)	2.13 (0.97)
9-Ounce Metal	3.5 (88)	7.6 (193)	1.1 (28)	3.1 (79)	2.13 (0.97)
Extended Metal	3.5 (88)	11.2 (284)	1.1 (28)	3.1 (79)	2.31 (1.05)

† Bowl removal clearance: add 3.1 (79) for 9-ounce bowl; 6.1 (155) for extended bowl.

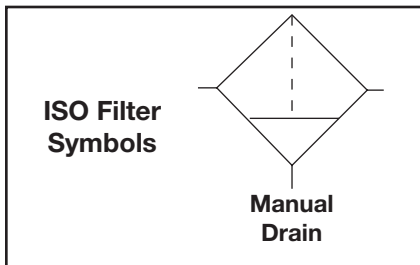
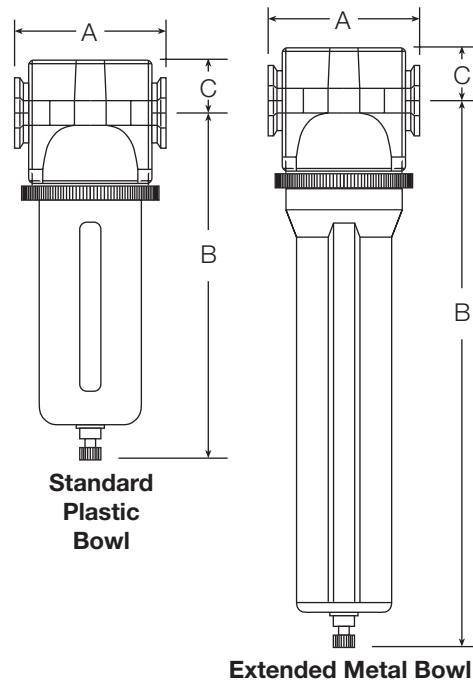

**REPLACEMENT FILTER ELEMENT KITS**

Bowl Size	Kit Number
Standard (Std element).....	A115-117E9
Extended .....	A115-118E9

**ORDERING INFORMATION**

Change the letters in the sample model number below to specify the filter you want.

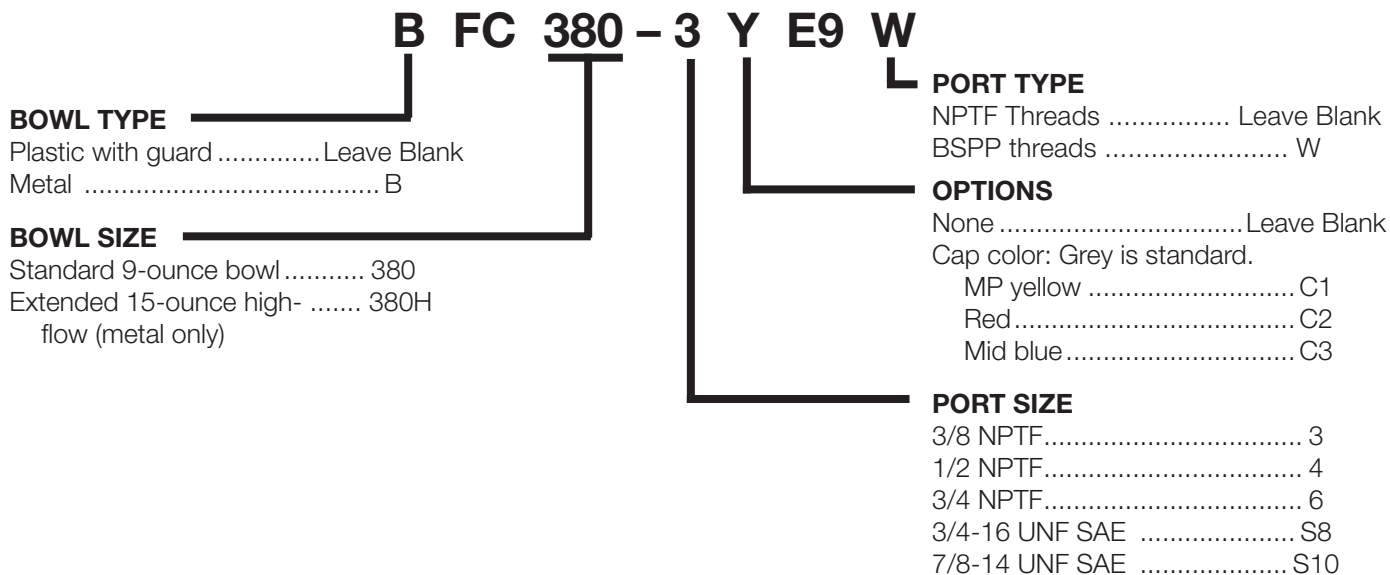

# GUARDSMAN II

## Clean Air Package



Model Shown: BMDFCDFC70-4E9

These assemblies consist of three filters: a general purpose filter, a coalescing filter, and an adsorbing filter. The general purpose filter removes gross contaminants, while the coalescing filter removes oil mists, aerosols, and minute particles. Finally, the adsorbing filter virtually eliminates odors from Freons, alcohols, esters, ketones, and up to 99% of most hydrocarbons.

### SPECIFICATIONS

**Ambient/Media Temperature:**

40° to 175°F (4° to 79°C).

**Body:** Zinc.

Bowls: 6-Ounce (180-ml) capacity aluminum. Clear nylon sight glass on general purpose and coalescing filters. Bowls are rotatable for easy readability. Optional 10-ounce (300-ml) extended aluminum bowls have higher flow elements for coalescing and adsorbing filters.

**Bowl Ring:** Nylon.

**Filter Bowl Drains:**

Internal automatic drains for general purpose and coalescing filters; manual drain for adsorbing filter.

**Filter Elements:** General purpose: 5- $\mu$ m-rated polyethylene; optional 5- $\mu$ m sintered bronze. Coalescing: 0.3- $\mu$ m-rated borosilicate glass fiber; optional 0.01- $\mu$ m-rated element.

**Adsorbing:** Activated carbon with urethane seals.

**Fluid Media:** Compressed air.

**Inlet Pressure:**

Minimum: 15 psig (1 bar).  
Maximum: 200 psig (14 bar).

# BMDFCDFC70-E9 Models

## Port Sizes: 1/4, 3/8, 1/2

- ◆ Modular or inline mounting.
- ◆ 5- $\mu$ m-rated polyethylene general purpose filter element.
- ◆ 0.3- $\mu$ m-rated coalescing filter element; optional 0.01- $\mu$ m element.
- ◆ Metal bowls. Clear nylon sight glass on general purpose and coalescing filters. Bowls rotatable for easy readability.
- ◆ Optional extended bowls include higher capacity filter elements for coalescing and adsorbing filters.
- ◆ Internal automatic filter drain for general purpose and coalescing filters. Manual drain for adsorbing filter.
- ◆ Differential pressure gauge on coalescing filter to indicate when filter element needs changing.
- ◆ **NPTF** port threads; optional **SAE** or **BSP** threads.

### AIR FLOW and CONSTRUCTION DATA

See Flow Charts and Specifications for individual assembly components on preceding pages.

**DIMENSIONS** inches (mm)

Bowl	A	B	C	Depth	Weight lb (kg)
Standard	8.4 (213)	5.1 (129)	1.8 (45)	2.4 (60)	5.00 (2.27)
Extended	8.4 (213)	8.1 (206)	1.8 (45)	2.4 (60)	5.25 (2.39)

**REPLACEMENT FILTER ELEMENT KITS**

Element	Model Usage	Kit Number
5-µm Plastic (Std)	General purpose filter	A60F-03PE5
5-µm Bronze	General purpose filter	KA60F-03E5
0.3-µm (Std) Coalescing	Standard bowl	A60F-29
	Extended bowl	A60F-32
0.01-µm Coalescing	Standard bowl	A60F-29E8
	Extended bowl	A60F-32E8
Adsorbing	Standard bowl	A60F-29E9
	Extended bowl	A60F-32E9

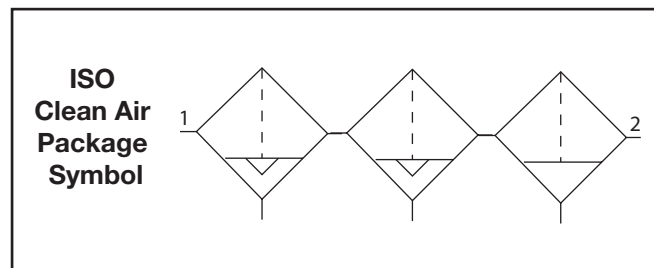
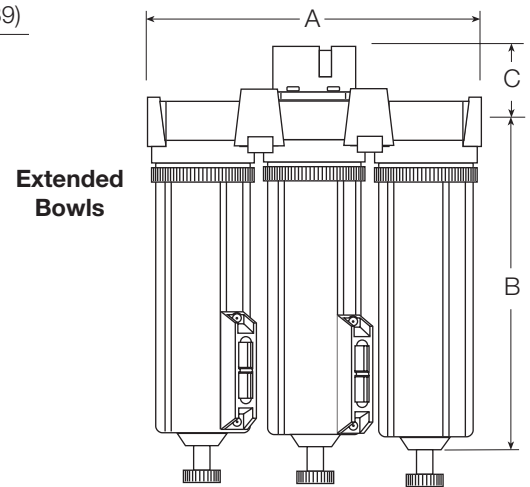
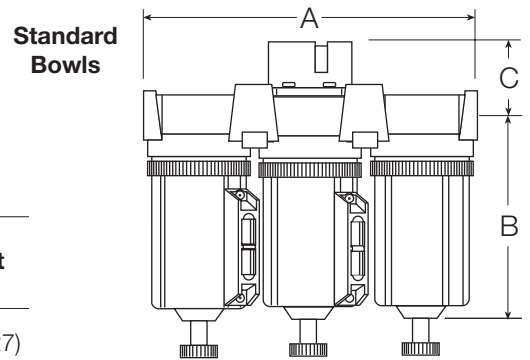

**ORDERING INFORMATION**

Change the letters in the sample model number below to specify the Clean Air Package you want.

**BMFDFCFC 70 - 2 Y E9 W**

**BOWL SIZE**

- Standard 6-ounce bowls ..... 70
- Extended 10-ounce bowls..... 70H

**PORT SIZE**

- 1/4 NPTF..... 2
- 3/8 NPTF..... 3
- 1/2 NPTF..... 4
- 9/16-18 UNF SAE ..... S6

**PORT TYPE**

- NPTF Threads ..... Leave Blank
- BSPP threads ..... W

**OPTIONS**

- None ..... Leave Blank
- 5-µm sintered bronze general purpose filter element ..... E5
- 0.01-µm coalescing filter ..... E8 element

# Full-Size SERIES 380 Modular Clean Air Package

Model Shown: AAM1DOA1J9D



The general purpose filter in this assembly removes gross contaminants, while the coalescing filter removes oil mists, aerosols, and minute particles. Finally, the adsorbing filter effectively eliminates odors from Freons, alcohols, esters, ketones, and up to 99% of most hydrocarbons.

## SPECIFICATIONS

### Ambient/Media Temperature:

**Plastic bowls:** 40° to 125°F (4° to 52°C).

**Metal bowls:** 40° to 175°F (4° to 79°C).

**Bowls:** 9-Ounce (270-ml) capacity polycarbonate plastic bowls with steel shatterguards. Optional aluminum bowls; clear nylon sight glass on general purpose and coalescing units. Optional 15-ounce (450-ml) extended aluminum bowls with higher flow elements for coalescing and adsorbing filters.

**Cap Color:** Accent grey. Yellow, red, blue optional.

**Filter Drains:** Internal automatic drains for general purpose and coalescing filters; manual drain for adsorbing filter.

### Filter Elements:

**General Purpose:** 5- $\mu$ m-rated polyethylene.

**Coalescing:** 0.3- $\mu$ m-rated borosilicate glass-fiber; optional 0.01- $\mu$ m-rated element.

**Adsorbing:** Activated carbon with urethane seals.

**Fluid Media:** Compressed air.

### Inlet Pressure:

15 psig (1 bar) minimum with automatic drain.

**Plastic bowls:** 150 psig (10 bar) maximum.

**Metal bowls:** 200 psig (14 bar) maximum.

## AAM1D0A1A9 Models Port Sizes: 3/8, 1/2, 3/4

- ◆ General purpose filter (FD380) with 5- $\mu$ m-rated polyethylene filter element.
- ◆ Coalescing filter with 0.3- $\mu$ m-rated coalescing element; optional 0.01- $\mu$ m element.
- ◆ Adsorbing filter with activated carbon element.
- ◆ Modular or inline mounting.
- ◆ Polycarbonate plastic bowls with steel shatterguards; optional metal bowls.
- ◆ Optional extended metal bowls for coalescing and adsorbing filters include higher flow filter elements.
- ◆ Internal automatic drains for general purpose and coalescing filters. Manual drain for adsorbing filter.
- ◆ Differential pressure gauge on coalescing filter to indicate when element needs changing.
- ◆ **NPTF** port threads; optional **SAE** or **BSPP** threads.

### AIR FLOW and CONSTRUCTION DATA

See Flow Charts and Specifications for individual assembly components on preceding pages.

### DIMENSIONS inches (mm)

Bowls	A	B †	C	Weight Depth	lb (kg)
Standard	10.9 (276)	7.7 (195)	2.2 (55)	2.9 (73)	6.63 (3.01)
Extended	10.9 (276)	11.2 (284)	2.2 (55)	2.9 (73)	7.00 (3.18)

† Bowl removal clearance: add 3.4 (86) for 9-ounce bowl; 6.1 (155) for extended bowl.

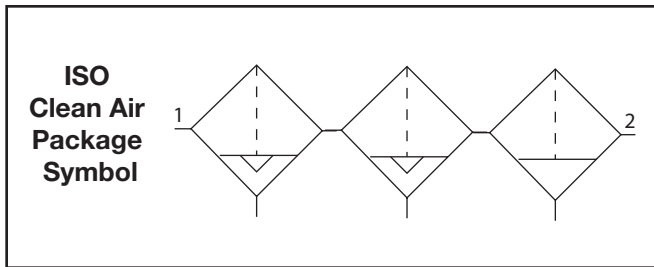
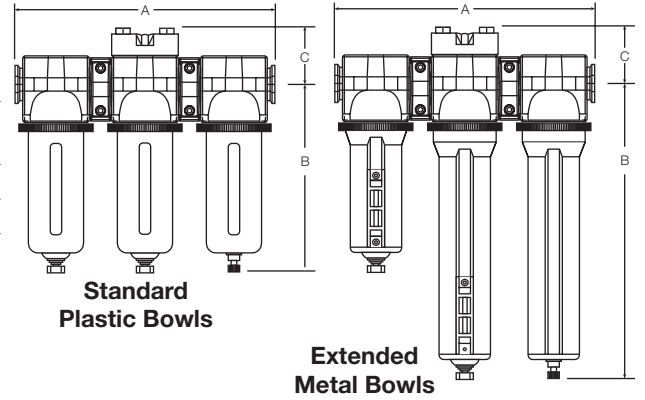

### REPLACEMENT FILTER ELEMENT KITS

Element Type	Kit Number
<b>General Purpose</b> 5-µm (Std element) .....	A115-106PE5
<b>Coalescing:</b> 0.3 µm Standard bowl (Std element) ....	A115-117
0.3 µm Extended bowl.....	A115-118
0.01 µm Standard bowl .....	A115-117E8
0.01 µm Extended bowl .....	A115-118E8
<b>Adsorbing:</b> Standard bowl (Std cartridge) .....	A115-117E9
Extended bowl.....	A115-118E9

### ORDERING INFORMATION

Change the letters in the sample model number below to specify the Clean Air Package you want.

A A M 1 D 0 A 1 A 9 6

<p><b>CAP COLOR</b></p> <ul style="list-style-type: none"> <li>Accent grey ..... A</li> <li>MP yellow..... B</li> <li>Red ..... C</li> <li>Mid blue ..... D</li> </ul> <p><b>BOWL TYPE</b></p> <ul style="list-style-type: none"> <li>9-Ounce plastic ..... A</li> <li>9-Ounce metal ..... B</li> <li>Metal: 9-ounce general purpose ... D filter; 15-ounce coalescing and adsorbing filters</li> </ul> <p><b>COALESCING FILTER ELEMENT</b></p> <ul style="list-style-type: none"> <li>0.3-µm element (Std) ..... D</li> <li>0.01-µm element ..... E</li> </ul> <p><b>DRAIN TYPES</b></p> <ul style="list-style-type: none"> <li>Manual drain for general purpose ... 0 and coalescing filters</li> <li>Internal automatic drain for ..... 1 general purpose and coalescing filters</li> </ul>	<p><b>PORT SIZE</b></p> <ul style="list-style-type: none"> <li>3/8 NPTF..... 3</li> <li>1/2 NPTF..... 4</li> <li>3/4 NPTF..... 6</li> <li>3/8 BSPP ..... C</li> <li>1/2 BSPP ..... D</li> <li>3/4 BSPP ..... E</li> <li>3/4-16 UNF SAE ..... F</li> <li>7/8-14 UNF SAE ..... G</li> </ul> <p><b>DIFFERENTIAL PRESSURE GAUGES:</b> For additional gauge options see page 291.</p> <ul style="list-style-type: none"> <li>No gauge on coalescing filter..... 0</li> <li>Small gauge (K103-151) on ..... 9 coalescing filter (standard)</li> <li>Large gauge (106-35) on ..... A coalescing filter</li> </ul> <p><b>PORTS &amp; MOUNTING BRACKETS</b></p> <ul style="list-style-type: none"> <li>No end ports or brackets..... A</li> <li>Mounting brackets only ..... J</li> <li>Female end ports with ..... K mounting brackets</li> </ul>
--	---

# MP-FILENCO Dryer/Filters

## Series 25 Port Size: 1/4

Model Shown: CD25-2D3M



Many compressed air systems require point-of-use cleaning and drying of the air to supplement a central system. MP-Fileenco dryer/filter units perform superbly because of their triple-action cleaning process and their ability to reduce the pressure dew point. See the sketch on page 95 for a cross-section view of a typical dryer/filter.

The filtering and drying functions result in super clean, super dry air. Several drain options and choices of desiccants are available to suit various operating needs.

### SPECIFICATIONS

**Ambient/Media Temperature:**

40° to 125°F (4° to 52°C).

**Drain:** Automatic drain; optional manual or electronic drains.

**Desiccant:** Choice of three.

**Flow Rate:** 7 scfm (3.3 l/s).

**Fluid Media:** Compressed air.

**Inlet Pressure:** 150 psig (10 bar) maximum. Consult Master Pneumatic for higher pressure ratings.

### DESICCANTS

The desiccants in **MP-Fileenco** dryer/filters have the ability to drop the pressure dew point thereby preventing the recurrence of water in the air system. They also adsorb sulfur compounds that form abrasive, gummy varnish or shellac. Three different desiccants are available.

**CLAY DESICCANT (CD)** — This is a general purpose desiccant which produces initial dew point depressions of 20 to 25 degrees Fahrenheit. It is effective for removing both water and oil, and requires no air preparation. Life expectancy is up to three months, depending on humidity, flow rate, and frequency of use.

**CLAY DESICCANT WITH ACTIVATED CARBON (CDC)** — This desiccant provides a higher degree of air purification than the plain clay desiccant. A layer of activated carbon produces slightly lower initial dew points, and also provides better removal of noxious gases and oil aerosols.

**MOLECULAR SIEVE DESICCANT (MS)** — Highly porous alumina-silicate complexes in this desiccant produce exceptionally low pressure dew points, as much as 80 Fahrenheit degrees initially. A dryer/filter with this desiccant must be preceded by a coalescing filter. The presence of oil in the air will contaminate the molecular sieve material and greatly reduce its efficiency. The coalescing pre-filter, of course, should be preceded by a general purpose filter.



## DIMENSIONS inches (mm)

A with Drain								
Series	A No Drain	D1, D2 D3, D4	D5	D6	D7	D8	B	Depth
25	7.0 (178)	12.3 (311)	9.5 (241)	10.5 (267)	11.6 (295)	9.5 (241)	2.6 (67)	3.5 (89)

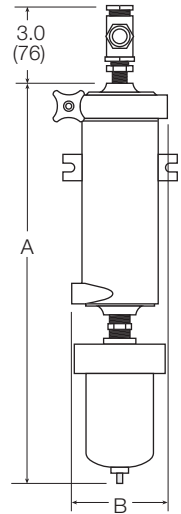

bsorbing Filters, Dryers,  
Clean Air Packages

### FLOW CHART

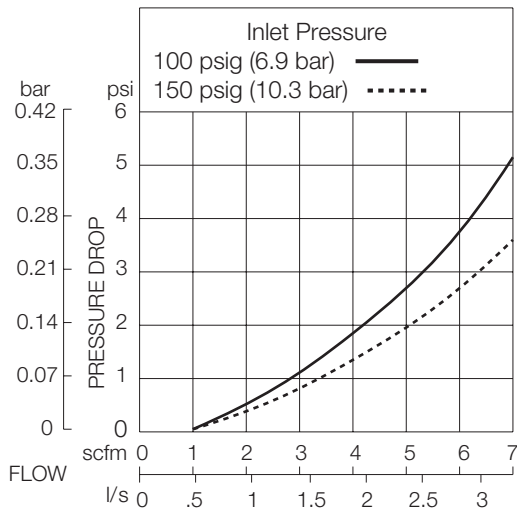

### REPLACEMENT DESICCANT ELEMENT KITS

Description	Quantity (per case)	Kit Number
Clay Desiccant Elements Series 25.....	4	CD-25NRE
Clay with Activated Carbon Series 25.....	4	CDC-25NRE
Molecular Sieve Elements Series 25.....	4	MS-25NRE

Note: Replacement kits include parts for both the older and current designs of filter discs.

### ORDERING INFORMATION

Change the letters in the sample model number below to specify the dryer/filter you want.

**CD 25-2 D1 M W**

**DESICCANT**

- Clay.....CD
- Clay with carbon.....CDC
- Molecular sieve.....MS

**DRAIN**

- None ..... Leave Blank
- Polycarbonate bowl; plastic bowl guard:
  - Manual drain PGM-25..... D1
  - Automatic float drain..... D2
  - PGA-25
- Metal bowl with sight glass:
  - Manual drain MSM-25..... D3
  - Automatic float drain..... D4
  - MBA-25
- Air poppet (actuator required);
  - 24v heated drain; ..... D6
  - temperature controlled
- Air poppet with 24v adjustable ..... D7
- cycle heated electronic timer
- Warrior electronic 115vac drain ..... D8

**PORT TYPE**

- NPTF Threads ..... Leave Blank
- BSP threads ..... W

**MOISTURE INDICATOR**

- None ..... Leave Blank
- With moisture indicator..... M
- MI375

# MP-FILENCO Dryer/Filters

# Series 36 and 38 Port Sizes: 3/8 and 1/2



Model Shown: CD36-3D1M



Model Shown: CD38-3D1M

## SPECIFICATIONS

### Ambient/Media Temperature:

40° to 125°F (4° to 52°C).

**Drain:** Automatic drain; optional manual or electronic drains.

**Desiccant:** Choice of three.

**Fluid Media:** Compressed air.

**Inlet Pressure:** 150 psig (10 bar) maximum. Consult Master Pneumatic for higher pressure ratings.

**Mounting:** Flanges and front ports for flush mounting.

Many compressed air systems require point-of-use cleaning and drying of the air to supplement a central system. MP-Fileenco dryer/filter units perform superbly because of their triple-action cleaning process and their ability to reduce the pressure dew point. See the sketch on page 95 for a cross-section view of a typical dryer/filter.

The filtering and drying functions result in super clean, super dry air. Several drain options and choices of desiccants are available to suit various operating needs. Units have flanges and front ports for flush mounting.

## DESICCANTS

The desiccants in MP-Fileenco dryer/filters have the ability to drop the pressure dew point thereby preventing the recurrence of water in the air system. They also adsorb sulfur compounds that form abrasive, gummy varnish or shellac. Three different desiccants are available.

**CLAY DESICCANT (CD)** — This is a general purpose desiccant which produces initial dew point depressions of 20 to 25 degrees Fahrenheit. It is effective for removing both water and oil, and requires no air preparation. Life expectancy is up to three months, depending on humidity, flow rate, and frequency of use.

**CLAY DESICCANT WITH ACTIVATED CARBON (CDC)** — This desiccant provides a higher degree of air purification than the plain clay desiccant. A layer of activated carbon produces slightly lower initial dew points, and also provides better removal of noxious gases and oil aerosols.

**MOLECULAR SIEVE DESICCANT (MS)** — Highly porous alumina-silicate complexes in this desiccant produce exceptionally low pressure dew points, as much as 80 Fahrenheit degrees initially. A dryer/filter with this desiccant must be preceded by a coalescing filter. The presence of oil in the air will contaminate the molecular sieve material and greatly reduce its efficiency. The coalescing pre-filter, of course, should be preceded by a general purpose filter.

## DIMENSIONS inches (mm)

A with Drain									
Series	A	D1, D2		D5	D6	D7	D8	B	Depth
	No Drain	D3, D4	D4						
36	9.5	13.5		12.4	12.3	13.4	12.4	4.0	5.0
	(241)	(343)		(314)	(311)	(295)	(314)	(102)	(127)
38	11.5	15.5		14.4	14.3	15.4	14.4	4.5	5.0
	(178)	(311)		(365)	(362)	(391)	(314)	(114)	(127)

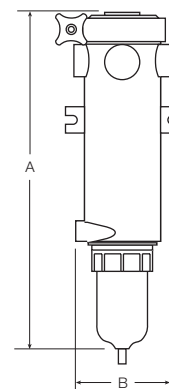

bsorbing Filters, Dryers,  
Clean Air Packages

### FLOW CHARTS

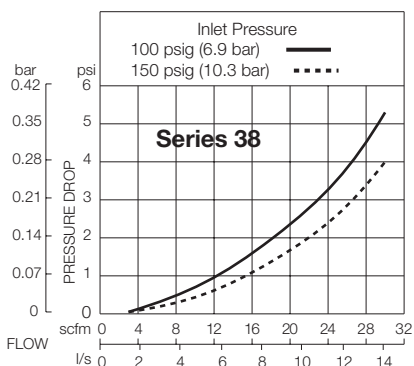
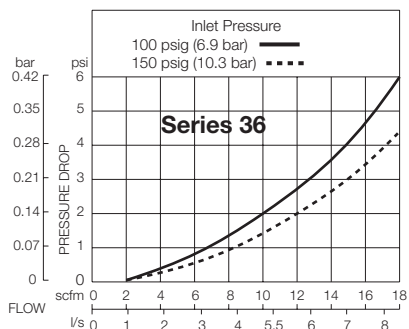

### REPLACEMENT DESICCANT ELEMENT KITS

Description	Quantity (per case)	Kit Number
<b>Clay Desiccant Elements</b>		
Series 36.....	4	CD-36NRE
Series 38.....	4	CD-38NRE
<b>Clay with Activated Carbon</b>		
Series 36.....	4	CDC-36NRE
Series 38.....	4	CDC-38NRE
<b>Molecular Sieve Elements</b>		
Series 36.....	4	MS-36NRE
Series 38.....	4	MS-38NRE

Note: Replacement kits include parts for both the older and current designs of filter discs.

### ORDERING INFORMATION

Change the letters in the sample model number below to specify the dryer/filter you want.

CD
36-3
D1
M
W

**DESICCANT**

Clay..... CD

Clay with carbon..... CDC

Molecular sieve..... MS

**SIZE**

3/8 NPTF — 18 scfm ..... 36-3

1/2 NPTF — 30 scfm ..... 38-4

**PORT TYPE**

NPTF Threads ..... Leave Blank

BSP threads ..... W

**MOISTURE INDICATOR**

None.....Leave Blank

With moisture indicator .....M  
(MI375)

**DRAIN**

None.....Leave Blank

Polycarbonate bowl; plastic bowl guard:

Manual drain PGM ..... D1

Automatic float drain .....D2  
PGA

Metal bowl with sight glass:

Manual drain MSM..... D3

Automatic float drain ..... D4  
MBA

Air poppet (actuator required);  
24v heated drain; temperature  
controlled ..... D6

Air poppet with 24v adjustable ..... D7  
cycle heated electronic timer

Warrior electronic 115vac drain ..... D8

# MP-FILENCO Dryer/Filters

**Series 418**  
**Port Size: 1**



**Model Shown:** CD418-8D1M

## SPECIFICATIONS

**Ambient/Media Temperature:**

40° to 125°F (4° to 52°C).

**Drain:** Automatic drain; optional manual or electronic drains.

**Desiccant:** Choice of three.

**Flow Rate:** 70 scfm.

**Fluid Media:** Compressed air.

**Inlet Pressure:** 150 psig (10 bar) maximum. Consult Master Pneumatic for higher pressure ratings.

**Mounting:** Flanges and front ports for flush mounting.

Many compressed air systems require point-of-use cleaning and drying of the air to supplement a central system. MP-Fileenco dryer/filter units perform superbly because of their triple-action cleaning process and their ability to reduce the pressure dew point. See the sketch on page 95 for a cross-section view of a typical dryer/filter.

The filtering and drying functions result in super clean, super dry air. Several drain options and choices of desiccants are available to suit various operating needs. Units have flanges and front ports for flush mounting.

## DESICCANTS

The desiccants in **MP-Fileenco** dryer/filters have the ability to drop the pressure dew point thereby preventing the recurrence of water in the air system. They also adsorb sulfur compounds that form abrasive, gummy varnish or shellac. Three different desiccants are available.

**CLAY DESICCANT (CD)** — This is a general purpose desiccant which produces initial dew point depressions of 20 to 25 degrees Fahrenheit. It is effective for removing both water and oil, and requires no air preparation. Life expectancy is up to three months, depending on humidity, flow rate, and frequency of use.

**CLAY DESICCANT WITH ACTIVATED CARBON (CDC)** — This desiccant provides a higher degree of air purification than the plain clay desiccant. A layer of activated carbon produces slightly lower initial dew points, and also provides better removal of noxious gases and oil aerosols.

**MOLECULAR SIEVE DESICCANT (MS)** — Highly porous alumina-silicate complexes in this desiccant produce exceptionally low pressure dew points, as much as 80 Fahrenheit degrees initially. A dryer/filter with this desiccant must be preceded by a coalescing filter. The presence of oil in the air will contaminate the molecular sieve material and greatly reduce its efficiency. The coalescing pre-filter, of course, should be preceded by a general purpose filter.

**DIMENSIONS** inches (mm)

Series	A with Drain							B	Depth
	A No Drain	D1, D2 D3, D4	D5	D6	D7	D8			
418	20 (508)	24 (610)	22.9 (581)	22.8 (578)	23.9 (606)	22.9 (581)	6.0 (152)	6.5 (165)	

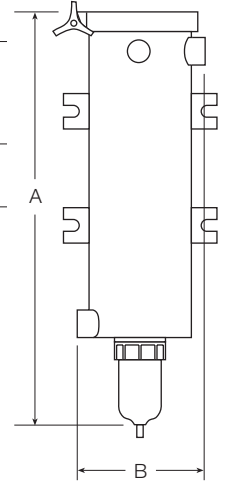

**FLOW CHARTS**

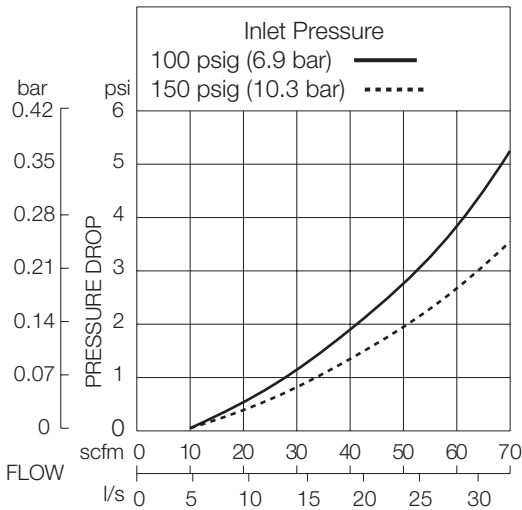

**REPLACEMENT DESICCANT ELEMENT KITS**

Description	Quantity (per case)	Kit Number
Clay Desiccant Elements Series 418.....	4	CD-418NRE
Clay with Activated Carbon Series 418.....	4	CDC-418NRE
Molecular Sieve Elements Series 418.....	4	MS-418NRE

Note: Replacement kits include parts for both the older and current designs of filter discs.

**ORDERING INFORMATION**

Change the letters in the sample model number below to specify the dryer/filter you want.

**CD 418-8 D1 M W**

**DESICCANT**

- Clay CD
- Clay with carbon..... CDC
- Molecular sieve..... MS

**DRAIN**

- None/Remove D1
- Polycarbonate bowl; plastic bowl guard:
  - Manual drain PGM ..... D1
  - Automatic float drain ..... D2
  - PGA
- Metal bowl with sight glass:
  - Manual drain MSM..... D3
  - Automatic float drain MBA..... D4
- Air poppet (actuator required); ..... D6
- 24v heated drain; temperature controlled
- Air poppet with 24v adjustable ..... D7
- cycle heated electronic timer
- Warrior electronic 115vac drain ..... D8

**PORT TYPE**

- NPTF Threads ..... Leave Blank
- BSP threads ..... W

**MOISTURE INDICATOR**

- None..... Leave Blank
- With moisture indicator ..... M
- MI750

# MP-FILENCO Dryer/Filters

## Series 625 and 832 Port Sizes: 1-1/2 and 2



Model Shown: CD625-12D1M

Model Shown: CD832-16D1M

### SPECIFICATIONS

**Ambient/Media Temperature:**

40° to 125°F (4° to 52°C).

**Drain:**

Automatic drain; optional manual or electronic drains.

**Desiccant:** Choice of three.

**Fluid Media:** Compressed air.

**Inlet Pressure:** 150 psig (10 bar) maximum. Consult Master Pneumatic for higher pressure ratings.

**Mounting:** Flanges and front ports for flush mounting.

Many compressed air systems require point-of-use cleaning and drying of the air to supplement a central system. MP-Fileenco dryer/filter units perform superbly because of their triple-action cleaning process and their ability to reduce the pressure dew point. See the sketch on page 95 for a cross-section view of a typical dryer/filter.

The filtering and drying functions result in super clean, super dry air. Several drain options and choices of desiccants are available to suit various operating needs. Units have flanges and front ports for flush mounting.

### DESICCANTS

The desiccants in MP-Fileenco dryer/filters have the ability to drop the pressure dew point thereby preventing the recurrence of water in the air system. They also adsorb sulfur compounds that form abrasive, gummy varnish or shellac. Three different desiccants are available.

**CLAY DESICCANT (CD)** — This is a general purpose desiccant which produces initial dew point depressions of 20 to 25 degrees Fahrenheit. It is effective for removing both water and oil, and requires no air preparation. Life expectancy is up to three months, depending on humidity, flow rate, and frequency of use.

**CLAY DESICCANT WITH ACTIVATED CARBON (CDC)** — This desiccant provides a higher degree of air purification than the plain clay desiccant. A layer of activated carbon produces slightly lower initial dew points, and also provides better removal of noxious gases and oil aerosols.

**MOLECULAR SIEVE DESICCANT (MS)** — Highly porous alumina-silicate complexes in this desiccant produce exceptionally low pressure dew points, as much as 80 Fahrenheit degrees initially. A dryer/filter with this desiccant must be preceded by a coalescing filter. The presence of oil in the air will contaminate the molecular sieve material and greatly reduce its efficiency. The coalescing pre-filter, of course, should be preceded by a general purpose filter.

## DIMENSIONS inches (mm)

SeriesNo	A with Drain							B	Depth
	A Drain	D1, D2 D3, D4	D5	D6	D7	D8			
625	21.3	25.3	24.1	24.0	25.1	24.1	8.5	8.0	
	(540)	(641)	(616)	(610)	(638)	(616)	(216)	(203)	
832	34	38	37.6	37.5	39.6	37.6	10	10.5	
	(864)	(965)	(956)	(953)	(1007)	(956)	(254)	(267)	

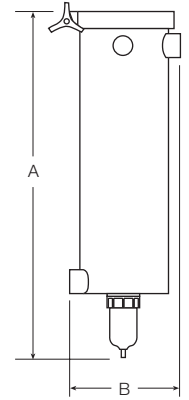

**Absorbing Filters, Dryers,  
Clean Air Packages**

### FLOW CHARTS

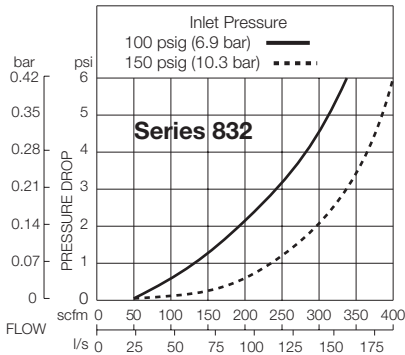
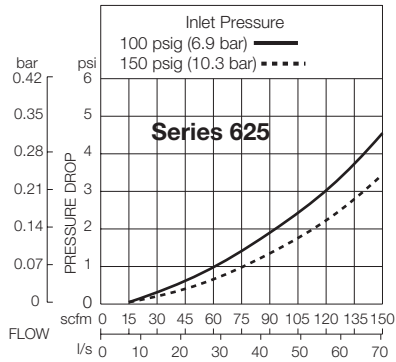

### REPLACEMENT DESICCANT ELEMENT KITS

Description	Quantity (per case)	Kit Number
<b>Clay Desiccant Elements</b>		
Series 625.....	2	CD-625NRE
Series 832.....	1	CD-832NRE
<b>Clay with Activated Carbon</b>		
Series 625.....	2	CDC-625NRE
Series 832.....	1	CDC-832NRE
<b>Molecular Sieve Elements</b>		
Series 625.....	2	MS-625NRE
Series 832.....	1	MS-832NRE

Note: Replacement kits include parts for both the older and current designs of filter discs.

### ORDERING INFORMATION

Change the letters in the sample model number below to specify the dryer/filter you want.

<p><b>DESICCANT</b></p> <p>Clay ..... CD  Clay with carbon..... CDC  Molecular sieve..... MS</p> <p><b>SIZE</b></p> <p>1-1/2 NPTF — 150 scfm ....625-12  2 NPTF — 300 scfm.....832-16</p>	<p><b>CD 625-12 D1 M W</b></p>	<p><b>PORT TYPE</b></p> <p>NPTF Threads ..... Leave Blank  BSP threads ..... W</p> <p><b>MOISTURE INDICATOR</b></p> <p>None ..... Leave Blank  With moisture indicator ..... M  MI750</p> <p><b>DRAIN</b></p> <p>None ..... Leave Blank  Polycarbonate bowl; plastic bowl guard:  Manual drain PGM ..... D1  Automatic float drain ..... D2  PGA  Metal bowl with sight glass:  Manual drain MSM ..... D3  Automatic float drain ..... D4  MBA  Air poppet (actuator required); ..... D6  24v heated drain; temperature controlled  Air poppet with 24v adjustable ..... D7  cycle heated electronic timer  Warrior electronic 115vac drain ..... D8</p>
---	--------------------------------	--

# PRESSURE REGULATORS

Master Pneumatic regulators are made in a wide range of sizes to suit nearly all industrial requirements for pneumatic pressure regulation. Good pressure regulation is essential to the efficient use of pneumatic equipment. A compressor may supply air at 150 psig, but most of the equipment will operate best at lower pressures. A cylinder, for example, may develop sufficient force for its purpose with 50-psig air. Remember that compressed air is costly, so using higher air pressure than necessary is wasteful, and may also shorten the life of the cylinder. A general purpose pressure regulator is the answer for greater economy and efficiency.



and quick response. All regulators are self-relieving, but a non-relieving option is available. A pressure gauge is standard, and gauge ports are at the front and the rear of each unit.

In addition there are precision regulators in all port sizes for applications demanding extra precision in the regulation of air pressure, plus regulators for remote, external piloting.

## MODULAR or INLINE MOUNTING

**SENTRY, GUARDSMAN, SERIES 380, and Full-Size VANGUARD** regulators are of modular design. Regulators are connected to filters or lubricators by special modular connectors which seal the faces between units. They may also be inline mounted with pipe nipples. **MINIATURE** and **High-Capacity VANGUARD** regulators are inline mounted only.

## SENTRY REGULATORS

Port sizes 1/8 and 1/4 or fittings for tubing up to 10 mm. Modular units have durable plastic, corrosion-resistant bodies. A non-relieving version can be used with water, oil, and many other liquids.

Regulators are of two basic designs. Piston design provides highest air flow; diaphragm design provides high sensitivity

## GUIDE to REGULATORS and SERVO VALVES

Regulator Series	Modular Construction	Port Sizes										Pages
		1/8	1/4	3/8	1/2	3/4	1	1-1/4	1-1/2	2		
<b>SENTRY †</b>												
General Purpose <b>R10M, R11M</b> models	yes	X	X									114-115
Water Pressure <b>R13M, R14M</b> models	yes	X	X									154-155
<b>MINIATURE</b>												
General Purpose <b>R55M, R56M</b> models	no	X	X									116-117
Stainless Steel <b>R56S</b> models	no		X									118-119
Precision <b>R57M</b> models	no	X	X									132-133
Externally Piloted <b>PR56M</b> models	no	X	X									140-141
Water Pressure <b>R53MB, R54MB</b> models	no	X	X									156-157
Relief Valves <b>RV56</b> models	no	X	X									158-159
<b>GUARDSMAN</b>												
General Purpose <b>R60</b> models	yes		X	X	X							120-121
<b>GUARDSMAN II</b>												
General Purpose <b>R75</b> models	yes		X	X	X							122-123
<b>Full-Size VANGUARD</b>												
General Purpose <b>R100</b> models	yes		X	X	X	X						124-125
Precision <b>IR100</b> models	yes		X	X	X	X						136-137
External Pilot <b>PR-PRH100</b> models	yes		X	X	X	X						144-147
<b>Full-Size SERIES 380</b>												
General Purpose <b>R380</b> models	yes			X	X	X						124-125
Precision <b>IR380</b> models	yes			X	X	X						134-135
External pilot <b>PR380</b> models	yes			X	X	X						142-143
<b>High-Capacity VANGUARD</b>												
General Purpose <b>R180M, R180</b> models	no					X	X	X	X			128-131
Precision <b>IR180M</b> models						X	X	X	X			138-139
External Pilot <b>PR180M, PRH180M, R200</b> models						X	X	X	X	X		148-153
Electro-Pneumatic Servo Valves												160-161

† Also available with quick-connect tube fittings up to 10 mm.



## MINIATURE REGULATORS

Port sizes 1/8, 1/4. Aluminum-bodied units for inline mounting. Same performance characteristics as the **SENTRY** models. Brass or stainless steel bodies, and water pressure models are also available.

**PRECISION MINIATURE** regulators are available to provide outstanding pressure control at relatively low cost. A large diaphragm area gives high sensitivity, and a small valve seat gives greater precision and little variation in outlet pressure from fluctuations in supply pressure. With an inlet pressure of 100 psig (7 bar), repeatability is within 1/4 psig. Regulated pressure range is 0–60 psig (0–4.1 bar). Optional springs allow other pressure ranges.

## GUARDSMAN REGULATORS

Port sizes 1/4, 3/8, 1/2. Modular units in a balanced-valve, piston design with very quick response for fast-cycling valves and cylinders. Two sub-series: **R60** models with durable plastic dome, and **R75** models with high-strength metal dome for more severe environments. Regulation performance is essentially the same.

## FULL-SIZE SERIES 380 and VANGUARD REGULATORS

Port sizes 1/4 to 3/4. Modular units with diaphragm design for sensitivity and accurate pressure regulation. An adjustment-locking key to prevent tampering is standard.

Full-Size **VANGUARD** and **SERIES 380 PRECISION** regulators are also available. They are of diaphragm design, and were developed to give superior torque control with pneumatic tools. However, they are well suited to many other applications because of their ability to regulate very high air flows with great precision. They will hold regulated pressure within 3 psig (0.2 bar), and repeatability is within 0.5 psig (0.034 bar). For torque control and applications that cannot tolerate over-pressurization, regulated pressure can be limited to 85 psig (5.9 bar). Air from a constant bleed, which is important to the precision of these units, is normally inaudible.

## HIGH-CAPACITY VANGUARD REGULATORS

Port sizes 3/4 to 1-1/2. Inline mounting and piston design are featured in these high-air-flow models. An adjustment-locking key to prevent tampering is standard.

**PRECISION** High-Capacity regulators are also available. They are of diaphragm design, and have essentially the same precise operating characteristics as the Full-Size **VANGUARD** precision regulators described above. Their larger port sizes, however, make them the choice for very high-air-flow applications.

## EXTERNALLY PILOTED REGULATORS

Regulators operated with external pilots are as precise as the external pilot regulators used. A 1/4" R55M pilot regulator (or R57M precision model) provides an accurately controlled air spring for excellent regulation. The pilot control regulator can be installed at a distance from the main regulator for convenience in making adjustments.



Full-Size **VANGUARD PRH100** High-Relief Regulators use a diaphragm design for high sensitivity. They provide air flows up to 160 scfm (94 l/s) in applications where low pressure drop and/or remote adjusting are desired.

High-Capacity **PR180M** and **PRH** (high-relief) **VANGUARD** Regulators are of diaphragm design, and provide air flows up to 600 scfm (284 l/s).

High-Capacity **R200** **VANGUARD** Regulators provide air flows up to 1000 scfm (474 l/s). For fast response, good sensitivity, and long service life they employ a piston traveling in a hard-anodized, Teflon-impregnated, metal cylinder. A high-flow, self-relieving valve is built into the main regulator.

## RELIEF VALVES

Relief valves are set for a desired maximum system pressure, and inserted in a tee downstream of regulated pressure to prevent over-pressurization of the system beyond the relief valve setting. Relief valves are adjustable from 1 to 125 psig (0.07 to 8.6 bar). Optional springs are available for other pressure ranges. If pressure exceeds the relief valve setting it will dump system air to atmosphere or to a valve to provide a warning signal.



Port sizes 1/8 and 1/4. A pressure gauge is standard equipment.

## ELECTRO-PNEUMATIC SERVO VALVES



Electro-pneumatic servo valves employ the latest in closed loop control technology. Flow rate is typically one scfm, but when used with a volume booster a flow rate in excess of 1,000 scfm can be achieved.

# SENTRY Modular General Purpose Regulators

## R10M, R11M Models Port Sizes: 1/8, 1/4; Tube Fittings



Model Shown: R10M-2G

- ◆ Modular assembly and mounting.
- ◆ Threaded ports or quick-connect fittings for tubing up to 10 mm in diameter.
- ◆ Piston-type design (R10M models) or diaphragm-type (R11M models).
- ◆ Self-relieving; non-relieving optional.
- ◆ Pressure gauge.
- ◆ NPTF port threads; optional BSPP threads or fittings for tubing up to 10 mm.

### SPECIFICATIONS

**Ambient/Media Temperature:**

40° to 125°F (4° to 52°C).

**Body:** Acetal.

**Dome and Knob:** Acetal

**Fluid Media:** Compressed air.

**Inlet Pressure:** 150 psig (10 bar) maximum.

**Outlet Pressure:** Adjustable up to 100 psig (7 bar).

**Pressure Gauge:** 0 to 160 psig (10.3 bar); 1/8 gauge ports front and rear.

**Panel Mounting:** 1-3/16 inch (30 mm) hole required.

**Seals:** Nitrile.

### FLOW CHART

Inlet Pressure: 100 psig (7 bar)

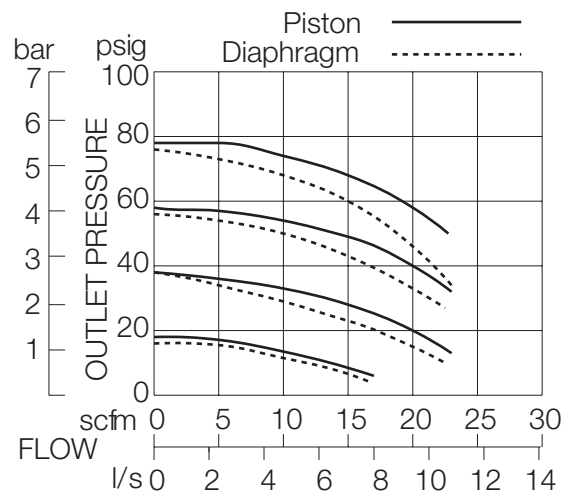

**DIMENSIONS** inches (mm)

Ports	A	B	C	Depth †	Weight † lb (kg)
No Port	1.7 (43)	2.6 (67)	0.5 (13)	1.8 (45)	0.21 (0.09)
1/8, 1/4	3.0 (76)	2.6 (67)	0.5 (13)	1.8 (45)	0.43 (0.19)

**Models below have quick-connect fittings for tubing.**

1/4	3.4 (86)	2.6 (67)	0.5 (13)	1.8 (45)	0.21 (0.09)
3/8	3.9 (99)	2.6 (67)	0.5 (13)	1.8 (45)	0.21 (0.09)
4 mm	3.4 (86)	2.6 (67)	0.5 (13)	1.8 (45)	0.41 (0.18)
6 mm	3.4 (86)	2.6 (67)	0.5 (13)	1.8 (45)	0.41 (0.18)
8 mm	3.1 (79)	2.6 (67)	0.5 (13)	1.8 (45)	0.41 (0.18)
10 mm	3.9 (99)	2.6 (67)	0.5 (13)	1.8 (45)	0.41 (0.18)

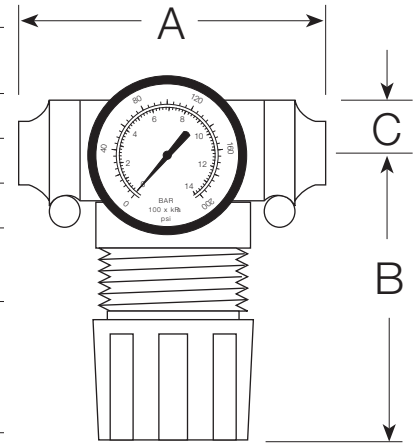

† Less gauge.

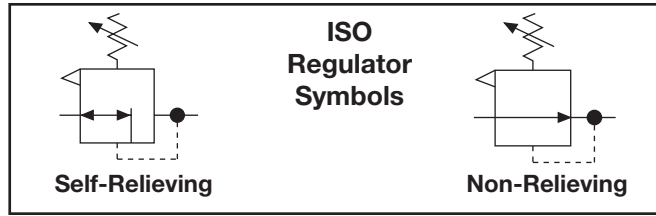

**ORDERING INFORMATION**

Change the letters in the sample model number below to specify the regulator you want.

**R10M P - 2 X Y G W**

**REGULATOR TYPE**

Piston type .....R10M  
Diaphragm type.....R11M

**MOUNTING HOLE LOCATION**

Bottom mount (Standard) ..... Leave Blank  
Top mount ..... P

**INLET PORT SIZE**

No Inlet and Outlet ports.... Leave blank

**Threaded:**

1/8 NPTF ..... -1  
1/4 NPTF ..... -2

**Fittings for Tubing:**

1/4 ..... -04  
3/8 ..... -06  
4 mm ..... -M4  
6 mm ..... -M6  
8 mm ..... -M8  
10 mm ..... -M10

**OUTLET PORT SIZE**

Same as inlet port ..... Leave Blank

**Threaded:**

1/8 NPTF ..... 1  
1/4 NPTF ..... 2

**Fittings for Tubing:**

1/4 ..... 04  
3/8 ..... 06  
4 mm ..... M4  
6 mm ..... M6  
8 mm ..... M8  
10 mm ..... M10

**MOUNTING BRACKETS**  
See page 276.

**PORT TYPE**

As specified in **INLET PORT**... Leave Blank  
BSPB threads on both ports ..... W

**OPTIONS** (More than one option can be chosen)

Delete gauge ..... Leave Blank  
0-160 PSI Gauge ..... G  
Plastic mounting nut ..... P  
Metal mounting nut..... PN  
Hex plastic mounting nut ..... PE

**OPTIONS** (More than one option can be chosen)

None ..... Leave Blank  
Non-relieving ..... A  
Springs: (0-100 psig standard)  
For optimum performance operating pressure should fall approximately in the middle of the spring range.  
0-125 psig (0-8.6 bar) ..... H  
0-50 psig (0-3.4 bar) ..... L  
0-8 psig (0-0.6 bar) ..... L8  
0-15 psig (0-1 bar) ..... L15  
0-30 psig (0-2.1 bar) ..... L30  
Tamper-resistant spinning ..... MV(\*)  
knob (psig preset)  
Viton seals..... V

\*Insert maximum limited pressure.

# MINIATURE General Purpose Regulators

# R55M, R56M Models Port Sizes: 1/8, 1/4



Model Shown: R55M-2G

- ◆ Inline mounting.
- ◆ Piston-type design (**R55M** models) or diaphragm-type (**R56M** models).
- ◆ Self-relieving; non-relieving optional.
- ◆ Pressure gauge.
- ◆ **NPTF** port threads; optional **BSPP** threads.

## SPECIFICATIONS

**Ambient/Media Temperature:**

40° to 125°F (4° to 52°C).

**Body:** Aluminum.

**Dome and Knob:** Acetal.

**Fluid Media:** Compressed air.

**Inlet Pressure:** 300 psig (21 bar) maximum.

**Outlet Pressure:** Adjustable up to 100 psig (7 bar).

**Pressure Gauge:** 0 to 160 psig (10.3 bar); 1/8 NPT gauge ports front and rear.

**Panel Mounting:** 1-3/16 inch (30 mm) hole required.

**Seals:** Nitrile.

## FLOW CHART

Inlet Pressure: 100 psig (7 bar)

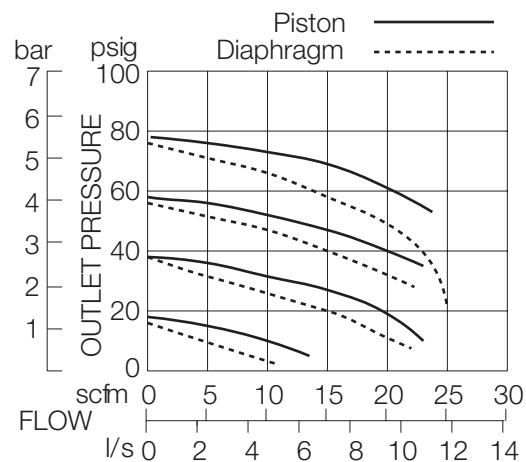

**DIMENSIONS** inches (mm)

A	B	C	Depth †	Weight † lb (kg)
1.6 (41)	2.7 (68)	0.4 (10)	1.6 (41)	0.24 (0.11)

† Less gauge.

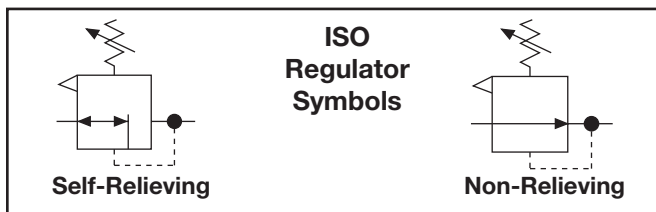
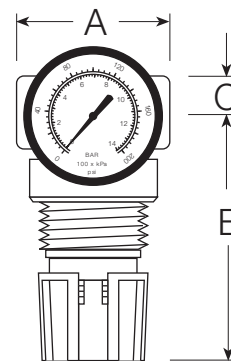

**ORDERING INFORMATION**

Change the letters in the sample model number below to specify the regulator you want.

**R55M B - 2 Y G W**

**REGULATOR TYPE**

Piston type .....R55M  
Diaphragm type.....R56M

**BODY MATERIAL TYPE**

Aluminum ..... Leave Blank  
Brass ..... B

**PORT SIZE**

1/8 NPTF..... 1  
1/4 NPTF..... 2

**PORT TYPE**

NPTF Threads ..... Leave Blank  
BSPB threads ..... W

**OPTIONS** (More than one option can be chosen)

Delete gauge ..... Leave Blank  
0-160 PSI Gauge ..... G  
Plastic mounting nut ..... P  
Metal mounting nut..... PN  
Hex plastic mounting nut ..... PE

**OPTIONS** (More than one option can be chosen)

None.....Leave Blank  
Non-relieving .....A  
Small valve seat.....C  
Metal dome (threaded).....D  
Springs: (0-100 psig standard)

For optimum performance operating pressure should fall approximately in the middle of the spring range.

0-125 psig (0-8.6 bar) .....H  
0-50 psig (0-3.4 bar) .....L  
0-8 psig (0-0.6 bar) .....L8  
0-15 psig (0-1 bar) .....L15  
0-30 psig (0-2.1 bar) .....L30

Tamper-resistant spinning knob (psig preset).....MV(\*)  
No gauge ports ..... NP  
Viton seals ..... V

\*Insert maximum limited pressure.

**MOUNTING BRACKETS**  
See page 276.

# MINIATURE Stainless Steel General Purpose Regulators

# R56S Models Port Sizes: 1/8, 1/4



Model Shown: R56S-2VG

- ◆ Stainless steel construction provides unique corrosion resistance.
- ◆ Viton elastomers throughout.
- ◆ Inline mounting.
- ◆ Diaphragm-type design.
- ◆ Self-relieving; non-relieving optional.
- ◆ Pressure gauge.
- ◆ NPTF port threads; optional BSPP threads.

## SPECIFICATIONS

**Ambient/Media Temperature:**

40° to 125°F (4° to 52°C).

**Body:** Stainless steel.

**Dome and Knob:** Acetal.

**Fluid Media:** Compressed air.

**Inlet Pressure:** 300 psig (21 bar) maximum.

**Outlet Pressure:** Adjustable up to 100 psig (7 bar).

**Pressure Gauge:** 0 to 200 psig (14 bar); 1/4 NPT gauge ports front and rear.

**Panel Mounting:** 1-3/16 inch (30 mm) hole required.

**Seals:** Viton.

## FLOW CHART

Inlet Pressure: 100 psig (7 bar)

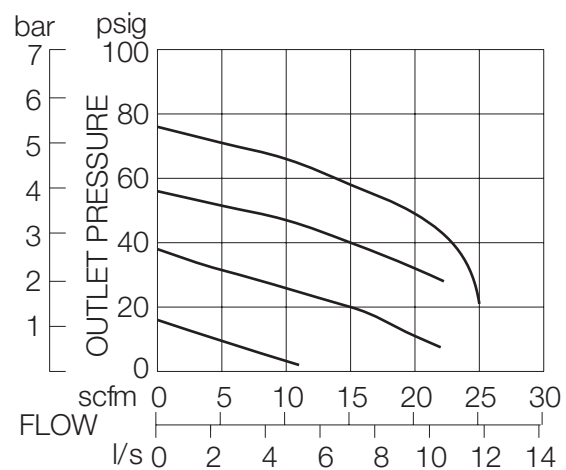

**DIMENSIONS** inches (mm)

A	B	C	Depth †	Weight † lb (kg)
1.6 (41)	2.7 (68)	0.4 (10)	1.6 (41)	0.24 (0.11)

† Less gauge.

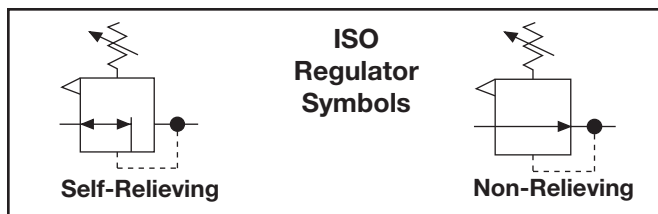
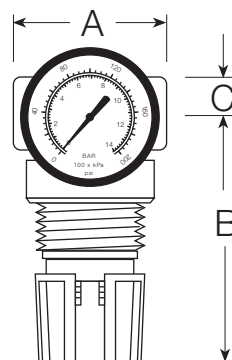

**ORDERING INFORMATION**

Change the letters in the sample model number below to specify the regulator you want.

**R56S - 2 Y V G W**

**PORT SIZE**

- 1/8 NPTF..... 1
- 1/4 NPTF..... 2

**PORT TYPE**

- NPTF Threads ..... Leave Blank
- BSPF threads ..... W

**OPTIONS** (More than one option can be chosen)

- Delete gauge ..... Leave Blank
- 0-160 PSI Gauge ..... G
- Plastic mounting nut ..... P
- Metal mounting nut..... PN
- Hex plastic mounting nut ..... PE

**MOUNTING BRACKETS**

See page 276.

**OPTIONS** (More than one option can be chosen)

- None ..... Leave Blank
- Non-relieving ..... A
- Springs: (0-100 psig standard)
- For optimum performance operating pressure should fall approximately in the middle of the spring range.
- 0-125 psig (0-8.6 bar) ..... H
- 0-50 psig (0-3.4 bar) ..... L
- 0-15 psig (0- 1 bar)..... L15
- 0-30 psig (0-2.1 bar) ..... L30

# GUARDSMAN Modular General Purpose Regulators

# R60 Models Port Sizes: 1/4, 3/8, 1/2



Model Shown: R60-4G

- ◆ Modular or inline mounting.
- ◆ Piston-type design.
- ◆ Self-relieving; non-relieving optional.
- ◆ Pressure gauge.
- ◆ **NPTF** port threads; optional **SAE** or **BSPP** threads.

## SPECIFICATIONS

**Ambient/Media Temperature:**

40° to 125°F (4° to 52°C).

**Body:** Zinc.

**Cap:** Nylon.

**Dome and Knob:** Acetal.

**Fluid Media:** Compressed air.

**Inlet Pressure:** 250 psig (17 bar) maximum.

**Outlet Pressure:** Adjustable up to 100 psig (7 bar).

**Pressure Gauge:** 0 to 200 psig (14 bar); 1/4 NPT gauge ports front and rear.

**Panel Mounting:** 1-9/16 inch (40 mm) hole required.

**Seals:** Nitrile.

## FLOW CHART

Inlet Pressure: 100 psig (7 bar)

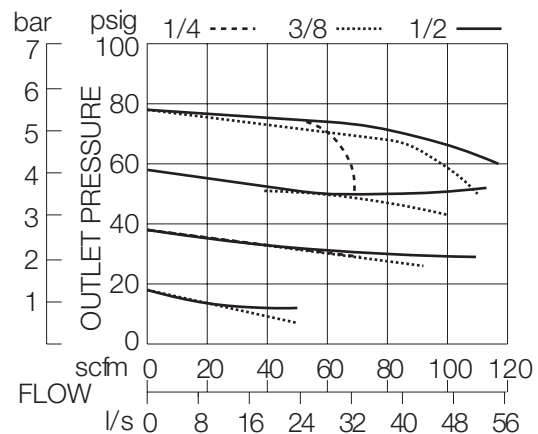



**DIMENSIONS** inches (mm)

A	B	C	Depth †	Weight † lb (kg)
2.7 (67)	3.3 (83)	1.3 (33)	2.1 (52)	1.0 (0.46)

† Less gauge.

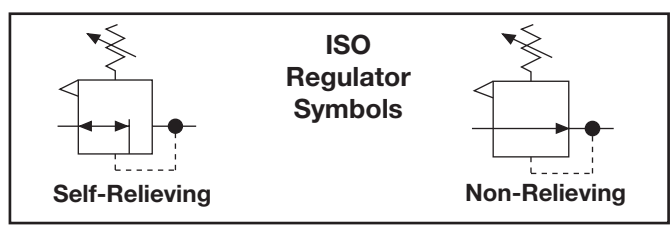
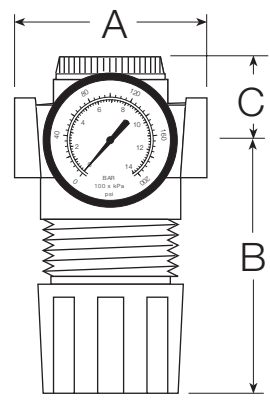

**ORDERING INFORMATION**

Change the letters in the sample model number below to specify the regulator you want.

**R60 - 2 Y G W**

**PORT SIZE**

- 1/4 NPTF..... 2
- 3/8 NPTF..... 3
- 1/2 NPTF..... 4
- 9/16-18 UNF SAE ..... S6

**OPTIONS** (More than one option can be chosen)

- None ..... Leave Blank
- Non-relieving ..... A
- Internal bypass–reverse flow..... E
- Springs: (0-100 psig standard)
  - For optimum performance operating pressure should fall approximately in the middle of the spring range.
  - 0-150 psig (0-10 bar) ..... H
  - 0-50 psig (0-3.4 bar) ..... L

**PORT TYPE**

- NPTF Threads ..... Leave Blank
- BSPB threads ..... W

**OPTIONS** (More than one option can be chosen)

- None ..... Leave Blank
- 0-200 psig Gauge ..... G
- Mounting nut ..... P

**MOUNTING BRACKETS**  
See page 276.

# GUARDSMAN II Modular General Purpose Regulators

# R75 Models Port Sizes: 1/4, 3/8, 1/2



Model Shown: R75-4G

- ◆ Modular or inline mounting.
- ◆ Piston-type design.
- ◆ Self-relieving; non-relieving optional.
- ◆ Extra-strength metal dome.
- ◆ Pressure gauge.
- ◆ Panel mounting nut.
- ◆ NPTF port threads; optional SAE or BSPP threads.

## SPECIFICATIONS

**Ambient/Media Temperature:**

40° to 175°F (4° to 79°C).

**Body:** Zinc.

**Dome:** Aluminum.

**Fluid Media:** Compressed air.

**Inlet Pressure:** 300 psig (21 bar) maximum.

**Knob:** Acetal.

**Outlet Pressure:** Adjustable up to 100 psig (7 bar).

**Pressure Gauge:** 0 to 200 psig (14 bar); 1/4 NPT gauge ports front and rear.

**Panel Mounting:**

Nut included. 1-7/8 inch (48 mm) hole required.

**Seals:** Nitrile.

**Valve:** Brass.

**Valve Cap:** Nylon.

## FLOW CHART

Inlet Pressure: 100 psig (7 bar)

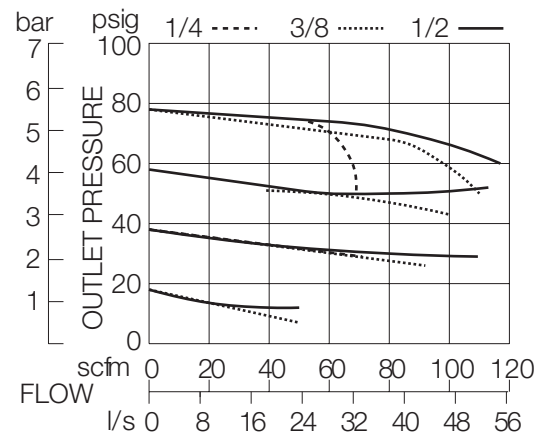

**DIMENSIONS** inches (mm)

A	B	C	Depth †	Weight † lb (kg)
2.7 (67)	5.8 (147)	1.3 (33)	2.1 (52)	1.13 (0.51)

† Less gauge.

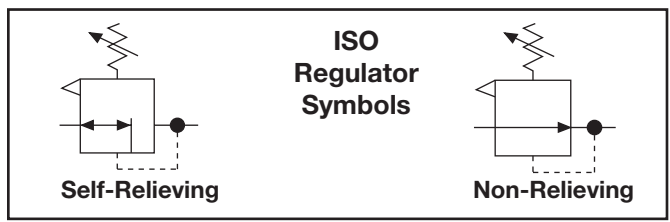
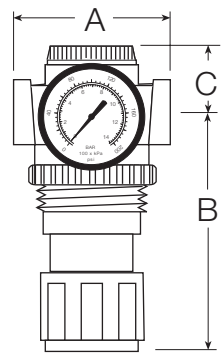

**ORDERING INFORMATION**

Change the letters in the sample model number below to specify the regulator you want.

**R75 - 2 Y G W**

**PORT SIZE**

- 1/4 NPTF..... 2
- 3/8 NPTF..... 3
- 1/2 NPTF..... 4
- 9/16-18 UNF SAE ..... S6

**PORT TYPE**

- NPTF Threads ..... Leave Blank
- BSPB threads ..... W

**OPTIONS** (More than one option can be chosen)

- None ..... Leave Blank
- 0-200 psig Gauge ..... G

**OPTIONS** (More than one option can be chosen)

- None ..... Leave Blank
- Non-relieving ..... A
- Adjustment-locking key ..... B
- Internal bypass–reverse flow ..... E
- Springs: (0-100 psig standard)

For optimum performance operating pressure should fall approximately in the middle of the spring range.

- 0-200 psig (0-14 bar) ..... H
- 0-50 psig (0-3.4 bar) ..... L
- Tee handle ..... T

**MOUNTING BRACKETS**  
See page 276.

# Full-Size VANGUARD Modular General Purpose Regulators

# R100 Models Port Sizes: 1/4, 3/8, 1/2, 3/4



Model Shown: R100-6G

## SPECIFICATIONS

**Ambient/Media Temperature:**

40° to 175°F (4° to 79°C).

**Body:** Zinc.

**Dome:**

Nylon; aluminum with optional 0-175 psig spring.

**Fluid Media:** Compressed air.

**Inlet Pressure:** 300 psig (21 bar) maximum.

**Knob:** Acetal.

**Outlet Pressure:** Adjustable up to 125 psig (8.6 bar).

**Pressure Adjustment Locking Key:** Removable.

**Pressure Gauge:** 0 to 200 psig (14 bar); 1/4 NPT gauge ports front and rear.

**Panel Mounting:** 2-1/16 inch (52 mm) hole required.

**Seals:** Nitrile.

**Valve:** Brass.

**Valve Cap:** Nylon.

- ◆ Modular or inline mounting.
- ◆ Diaphragm-type design.
- ◆ Self-relieving; non-relieving optional.
- ◆ Pressure gauge.
- ◆ Pressure adjustment locking key.
- ◆ NPTF port threads; optional SAE or BSPP threads.

## FLOW CHARTS

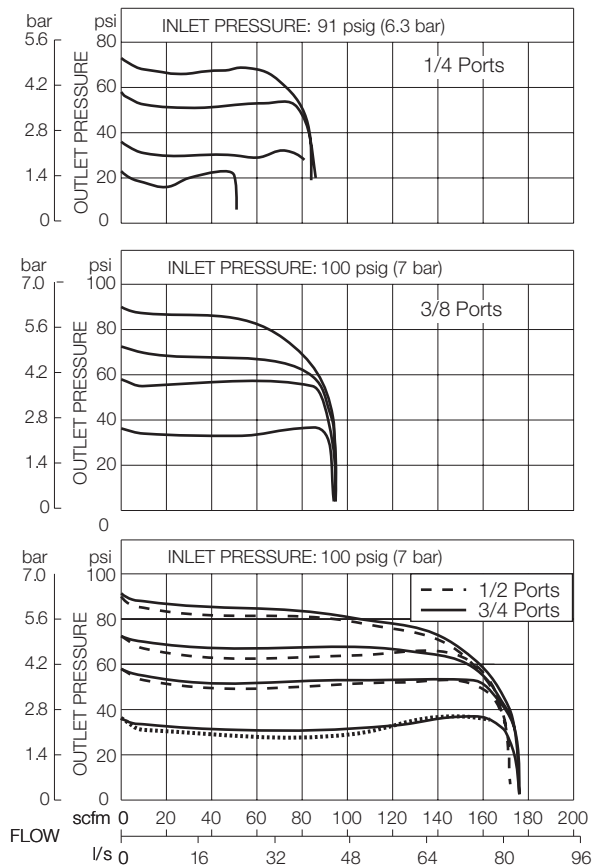

**DIMENSIONS** inches (mm)

A	B *	C **	Depth †	Weight † lb (kg)
3.5 (89)	5.8 (146)	1.3 (33)	2.8 (71)	2.06 (0.92)

\* Dome removal clearance: add 0.63 (16).

\*\* Cap removal clearance: add 0.5 (13).

† Less gauge.

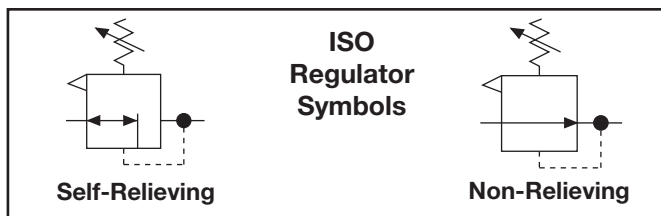
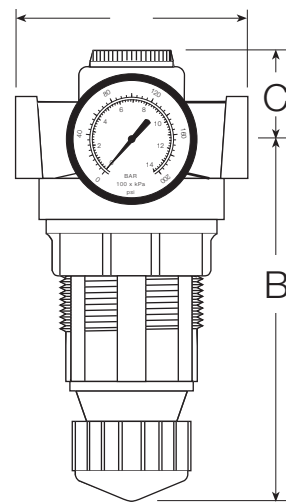

**ORDERING INFORMATION**

Change the letters in the sample model number below to specify the regulator you want.

**R100 - 2 Y G W**

**PORT SIZE**

- 1/4 NPTF..... 2
- 3/8 NPTF..... 3
- 1/2 NPTF..... 4
- 3/4 NPTF..... 6
- 9/16-18 UNF SAE ..... S6
- 3/4-16 UNF SAE ..... S8
- 7/8-14 UNF SAE ..... S10

**PORT TYPE**

- NPTF Threads ..... Leave Blank
- BSP threads ..... W

**OPTIONS** (More than one option can be chosen)

- None ..... Leave Blank
- 0-200 psig Gauge ..... G
- Mounting nut ..... P

**OPTIONS** (More than one option can be chosen)

- None ..... Leave Blank
- Non-relieving ..... A
- Internal bypass-reverse flow ..... E
- Springs: (0-125 psig standard)
  - For optimum performance operating pressure should fall approximately in the middle of the spring range.
  - 0-175 psig (0-12 bar) ..... H\*\*
  - 0-50 psig (0-3.4 bar) ..... L
  - 0-20 psig (0-1.4 bar) ..... L20
- Remove adjusting key ..... JJ
- Metal Dome ..... MD
- Limit maximum psig setting .... M\*
- Tee handle ..... T

\* Insert maximum limited pressure.

\*\* H option spring includes metal dome

**MOUNTING BRACKETS**  
See page 276.

# Full-Size SERIES 380 Modular General Purpose Regulators

# R380 Models Port Sizes: 3/8, 1/2, 3/4



Model Shown: R380-6G



- ◆ Modular or inline mounting. Modular mounting allows regulators to be positioned at increments of 45° for ease in adjustment.
- ◆ Self-relieving diaphragm design; large diaphragm sensing ratio; non-relieving optional.
- ◆ Pressure gauge.
- ◆ Pressure adjustment locking key; tamper-resistant pressure setting.
- ◆ NPTF port threads; optional SAE or BSPP threads.

## SPECIFICATIONS

**Ambient/Media Temperature:**  
40° to 175°F (4° to 79°C).

**Body:** Zinc.

**Dome:**  
Nylon; aluminum with optional 0-175 psig spring.

**Cap Color:** Accent grey. Yellow, red, and blue optional.  
Fluid Media: Compressed air.

**Inlet Pressure:** 300 psig (21 bar) maximum.

**Knob:** Acetal

**Outlet Pressure:** Adjustable up to 125 psig (8.6 bar); optional adjusting springs.

**Pressure Adjustment Locking Key:** Removable.

**Pressure Gauge:** 0 to 200 psig (14 bar); 1/4 NPT gauge ports front and rear.

**Panel Mounting:** 2-1/16 inch (52 mm) hole required.

**Seals:** Nitrile.

**Self-relieving:** Non-relieving optional.

**Valve:** Brass.

**Valve Cap:** Nylon.

## FLOW CHARTS

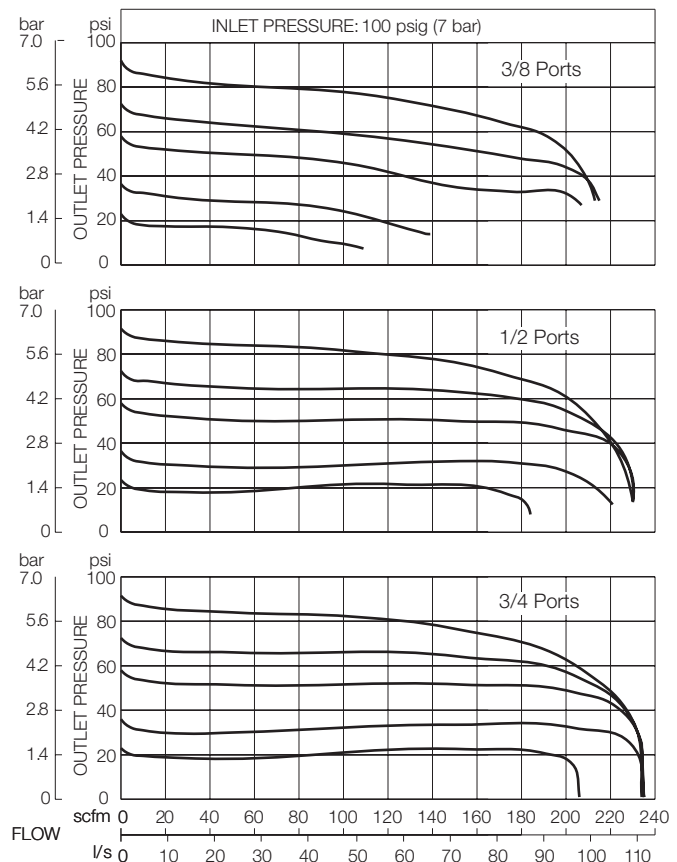

**DIMENSIONS** inches (mm)

A	B *	C **	Depth †	Weight † lb (kg)
3.5 (87)	5.6 (142)	1.6 (40)	2.9 (73)	2.56 (1.16)

\* Dome removal clearance: add 0.625 (16).

\*\* Cap removal clearance: add 0.50 (13).

† Less gauge.

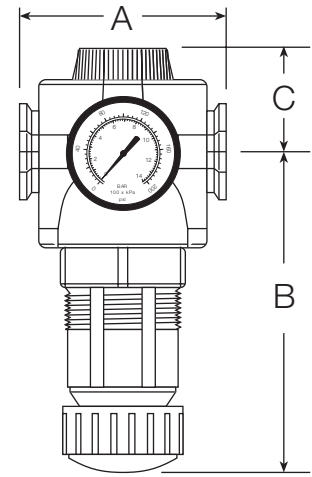

**Pressure REGULATORS**

**ORDERING INFORMATION**

Change the letters in the sample model number below to specify the regulator you want.

**R380 - 3 Y G W**

**PORT SIZE**

- 3/8 NPTF..... 3
- 1/2 NPTF..... 4
- 3/4 NPTF..... 6
- 3/4-16 UNF SAE ..... S8
- 7/8-14 UNF SAE ..... S10

**PORT TYPE**

- NPTF Threads ..... Leave Blank
- BSPP threads ..... W

**OPTIONS** (More than one option can be chosen)

- None ..... Leave Blank
- 0-200 psig Gauge ..... G
- Mounting nut ..... P

**OPTIONS** (More than one option can be chosen)

- None ..... Leave Blank
- Non-relieving ..... A
- Cap color: Grey is standard.
  - MP yellow ..... C1
  - Red ..... C2
  - Mid blue ..... C3
- Internal bypass - reverse flow ..... E
- Springs: (0-125 psig standard)
  - For optimum performance operating pressure should fall approximately in the middle of the spring range.
  - 0-175 psig (0-12 bar) ..... H\*\*
  - 0-50 psig (0-3.4 bar) ..... L
  - 0-20 psig (0-1.4 bar)..... L20
- Remove adjusting key ..... JJ
- Metal Dome ..... MD
- Limit maximum psig setting ..... M\*
- Tee handle..... T

\* Insert maximum limited pressure.

\*\* H option spring includes metal dome.

**MOUNTING BRACKETS**

See page 276.

# High-Capacity VANGUARD General Purpose Regulators

# R180M Models Port Sizes: 3/4, 1



Model Shown: R180M-6G

- ◆ Inline mounting.
- ◆ Piston-type design.
- ◆ Self-relieving; non-relieving optional.
- ◆ Pressure gauge.
- ◆ Pressure adjustment locking key.
- ◆ NPTF port threads; optional SAE or BSPP threads.

## SPECIFICATIONS

### Ambient/Media Temperature:

40° to 175°F (4° to 79°C).

**Body:** Aluminum.

### Dome:

Nylon; aluminum with optional 0-150 psig spring.

Fluid Media: Compressed air.

**Inlet Pressure:** 300 psig (21 bar) maximum.

**Knob:** Acetal

**Outlet Pressure:** Adjustable up to 100 psig (7 bar).

**Pressure Adjustment Locking Key:** Removable.

**Pressure Gauge:** 0 to 200 psig (14 bar); 1/4 NPT gauge ports front and rear.

**Panel Mounting:** 2-1/16 inch (52 mm) hole required.

**Seals:** Nitrile.

**Valve:** Brass.

**Valve Cap:** Nylon.

## FLOW CHARTS

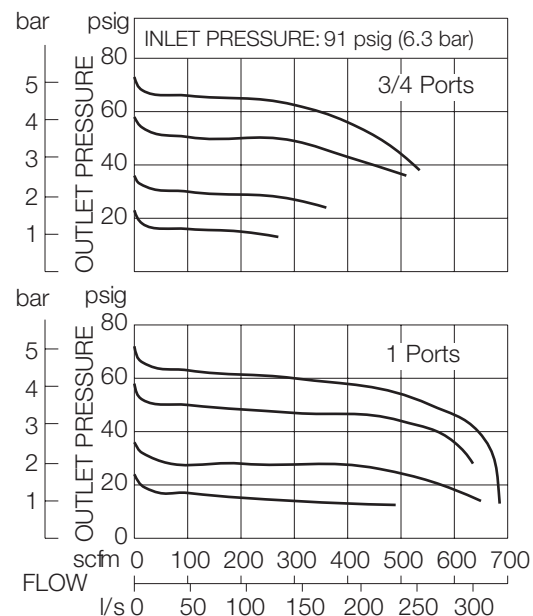



**DIMENSIONS** inches (mm)

A	B *	C **	Depth †	Weight † lb (kg)
4.4 (111)	6.1 (154)	2.4 (62)	2.8 (71)	2.19 (0.99)

\* Dome removal clearance: add 0.63 (16).

\*\* Cap removal clearance: add 0.65 (16.5).

† Less gauge.

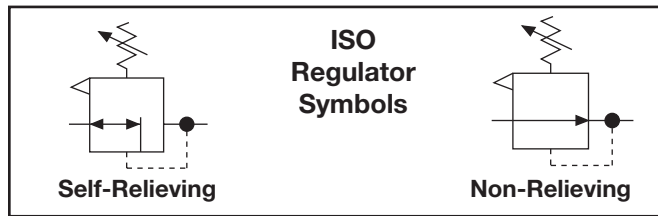
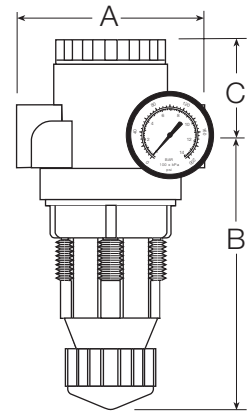

**ORDERING INFORMATION**

Change the letters in the sample model number below to specify the regulator you want.

**R180M - 6 Y G W**

**PORT SIZE**

- 3/4 NPTF..... 6
- 1 NPTF ..... 8
- 1-1/16-12 UNF SAE ..... S12
- 1-5/16-12 UNF SAE ..... S16

**PORT TYPE**

- NPTF Threads ..... Leave Blank
- BSPP threads ..... W

**OPTIONS** (More than one option can be chosen)

- None ..... Leave Blank
- 0-200 psig Gauge ..... G
- Mounting nut ..... P

**OPTIONS** (More than one option can be chosen)

- None ..... Leave Blank
- Non-relieving ..... A
- Internal bypass–reverse flow ..... E
- Springs: (0-100 psig standard)

For optimum performance operating pressure should fall approximately in the middle of the spring range.

- 0-150 psig (0-10 bar) ..... H\*\*
- 0-50 psig (0-3.4 bar) ..... L
- 0-20 psig (0-1.4 bar)..... L20

- Remove adjusting key 37-63 ..... JJ
- Metal Dome ..... MD
- Limit maximum psig setting .... M\*
- Tee handle..... T

\* Insert maximum limited pressure.

\*\* H option spring includes metal dome.

**MOUNTING BRACKETS**

See page 276.

# High-Capacity VANGUARD General Purpose Regulators

# R180 Models Port Sizes: 1-1/4, 1-1/2



Model Shown: R180-10G

- ◆ Inline mounting.
- ◆ Piston-type design.
- ◆ Self-relieving; non-relieving optional.
- ◆ Pressure gauge.
- ◆ Pressure adjustment locking key.
- ◆ **NPTF** port threads; optional **SAE** or **BSPP** threads.

## SPECIFICATIONS

**Ambient/Media Temperature:**

40° to 175°F (4° to 79°C).

**Body:** Aluminum.

**Dome:**

Nylon; aluminum with optional 0-150 psig spring.

**Fluid Media:** Compressed air.

**Inlet Pressure:** 300 psig (21 bar) maximum.

**Knob:** Acetal

**Outlet Pressure:** Adjustable up to 100 psig (7 bar).

**Pressure Adjustment Locking Key:** Removable.

**Pressure Gauge:** 0 to 200 psig (14 bar); 1/4 NPT gauge ports front and rear.

**Panel Mounting:** 2-1/16 inch (52 mm) hole required.

**Seals:** Nitrile.

**Valve:** Brass.

**Valve Cap:** Nylon.

## FLOW CHARTS

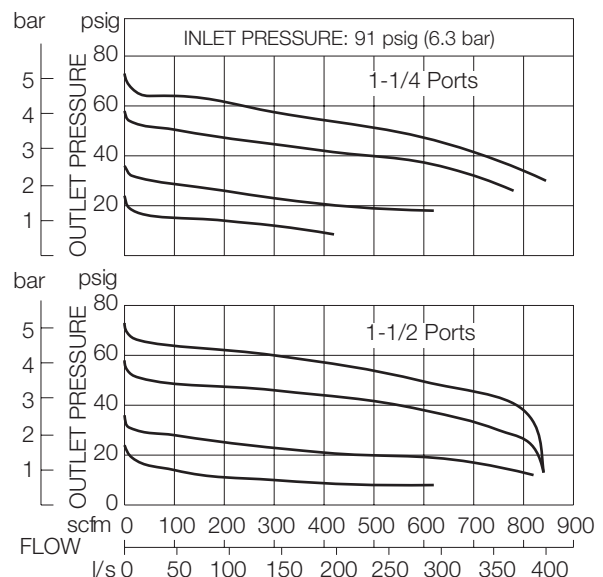

**DIMENSIONS** inches (mm)

A	B *	C **	Depth †	Weight † lb (kg)
4.9 (124)	6.4 (162)	2.1 (54)	2.8 (71)	2.5 (1.14)

\* Dome removal clearance: add 0.63 (16).

\*\* Cap removal clearance: add 0.65 (16.5).

† Less gauge.

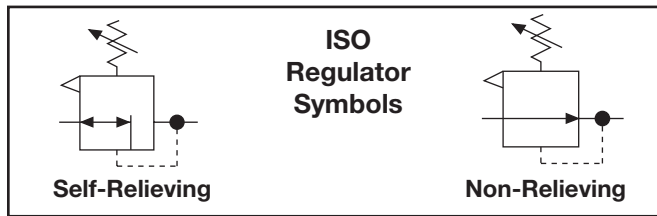
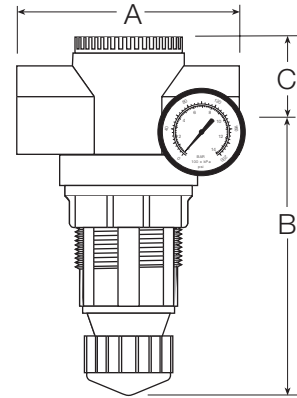

**ORDERING INFORMATION**

Change the letters in the sample model number below to specify the regulator you want.

**R180 - 10 Y G W**

**PORT SIZE**

- 1-1/4 NPTF ..... 10
- 1-1/2 NPTF ..... 12
- 1-5/8-12 UNF SAE ..... S20
- 1-7/8-12 UNF SAE ..... S24

**PORT TYPE**

- NPTF Threads ..... Leave Blank
- BSPB threads ..... W

**OPTIONS** (More than one option can be chosen)

- None ..... Leave Blank
- 0-200 psig Gauge ..... G
- Mounting nut ..... P

**OPTIONS** (More than one option can be chosen)

- None.....Leave Blank
- Non-relieving ..... A
- Internal bypass–reverse flow ..... E
- Springs: (0-100 psig standard)

For optimum performance operating pressure should fall approximately in the middle of the spring range.

0-150 psig (0-10 bar) .....H\*\*

0-50 psig (0-3.4 bar) ..... L

Remove adjusting key .....JJ

Metal Dome ..... MD

Limit maximum psig setting .... M\*

Tee handle..... T

\* Insert maximum limited pressure.

\*\* H option spring includes metal dome.

**MOUNTING BRACKETS**

See page 276.

# MINIATURE Precision Regulators

# R57M Models Port Sizes: 1/8, 1/4



Model Shown: R57M-2G

- ◆ Inline mounting.
- ◆ Diaphragm-type design.
- ◆ Self-relieving; non-relieving optional.
- ◆ Pressure gauge.
- ◆ NPTF port threads; optional BSPP threads.
- ◆ Repeatability  $\pm 0.25$  psig (0.017 bar)

## SPECIFICATIONS

### Ambient/Media Temperature:

40° to 125°F (4° to 52°C).

**Body:** Aluminum.

**Dome:** Aluminum.

**Fluid Media:** Compressed air.

**Inlet Pressure:** 300 psig (21 bar) maximum.

**Outlet Pressure:** Adjustable up to 50 psig (3.4 bar).  
Adjustable up to 160 psig (10.3 bar) with optional springs. With inlet pressure of 100 psig (7 bar) repeatability is within 0.25 psig

**Pressure Gauge:** 0 to 160 psig (10.3 bar); 1/8 NPT gauge ports front and rear.

**Panel Mounting:** 1-3/16 inch (30 mm) hole required.

**Seals:** Nitrile.

**Self-relieving:** Non-relieving optional.

## FLOW CHART

Inlet Pressure: 91 psig (6.3 bar)

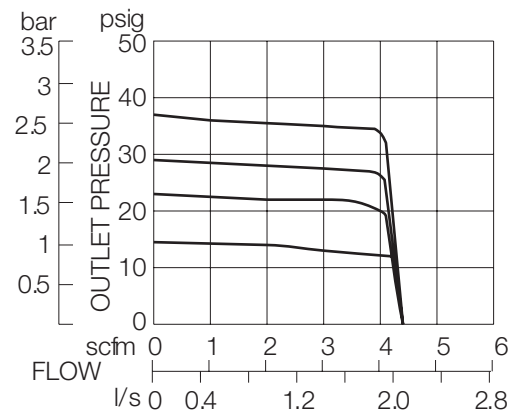

**DIMENSIONS** inches (mm)

A	B	C	Depth †	Weight † lb (kg)
1.8 (44)	3.4 (86)	0.4 (10)	1.8 (44)	0.38 (0.16)

† Less gauge.

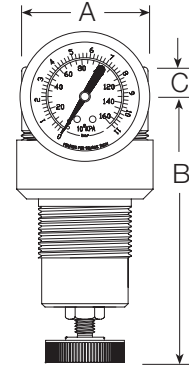

**ORDERING INFORMATION**

Change the letters in the sample model number below to specify the regulator you want.

**R57M - 2 Y G W**

**PORT SIZE**

- 1/8 NPTF..... 1
- 1/4 NPTF..... 2

**PORT TYPE**

- NPTF Threads ..... Leave Blank
- BSPP threads ..... W

**OPTIONS** (More than one option can be chosen)

- None..... Leave Blank
- Non-relieving ..... A
- Springs: (0-50 psig standard)
  - For optimum performance operating pressure should fall approximately in the middle of the spring range.
  - 0-60 psig (0-4.1 bar) ..... H
  - 0-20 psig (0-1.4 bar) ..... L20
  - 0-10 psig (0-0.7 bar) ..... L10
  - 0-5 psig (0-0.3 bar) ..... L5
- No gauge ports ..... NP
- Viton seals..... V

**OPTIONS** (More than one option can be chosen)

- Delete gauge ..... Leave Blank
- 0-160 PSI Gauge ..... G
- Plastic mounting nut ..... P
- Metal mounting nut..... PN
- Hex plastic mounting nut ..... PE

**MOUNTING BRACKETS**

See page 276.

# Full-Size SERIES 380 Modular Internally Piloted Precision Regulators

## IR380 Models Port Sizes: 3/8, 1/2, 3/4

### Available Color Caps



Model Shown: IR380-6G

Yellow  
(optional)



Red  
(optional)



Blue  
(optional)



Grey  
(standard)



- ◆ Modular or inline mounting.
- ◆ Self-relieving diaphragm design.
- ◆ Repeatability  $\pm 0.5$  psi (0.034 bar).
- ◆ Easy finger adjustment. No overshoot or undershoot when adjusting.
- ◆ Constant air bleed for high accuracy.
- ◆ Pressure gauge.
- ◆ NPTF port threads; optional SAE or BSPP threads.

### SPECIFICATIONS

**Ambient/Media Temperature:**

40° to 125°F (4° to 52°C).

**Body and Dome:** Zinc.

**Bonnet and Knob:** Acetal.

**Constant Air Bleed Rate:** 0.18 – 0.33 scfm at 80 psi secondary pressure

**Fluid Media:** Compressed air.

**Inlet Pressure:** 250 psig (17 bar) maximum.

**Outlet Pressure:** Adjustable 15 –200 psig (1– 13.7 bar).

**Pressure Gauge:** 0 to 200 psig (14 bar); 1/4 NPT gauge ports front and rear.

**Panel Mounting:** 2-1/16 (52 mm) hole required.

**Seals:** Nitrile.

**Self-relieving**

**Valve:** Brass.

### FLOW CHARTS

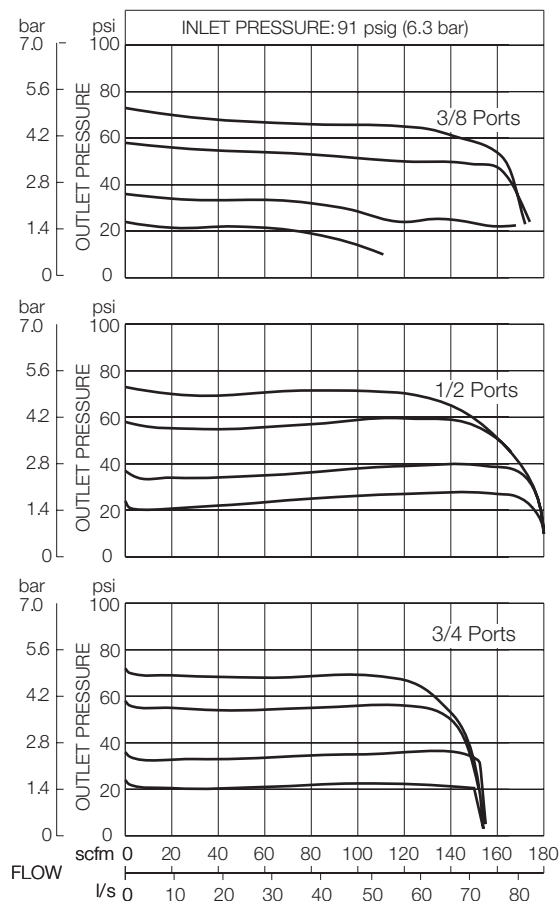

**DIMENSIONS** inches (mm)

A	B	C	Depth †	Weight † lb (kg)
3.5 (87)	4.8 (122)	1.6 (41)	2.9 (73)	2.3 (1.0)

† Less gauge.

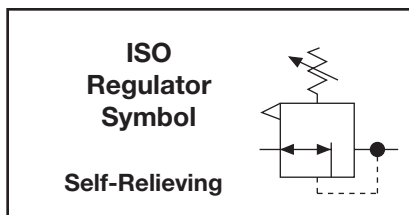
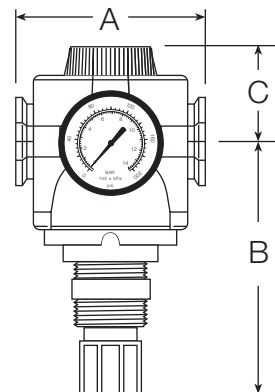

**ORDERING INFORMATION**

Change the letters in the sample model number below to specify the regulator you want.

**IR380 - 3 Y G W**

**PORT SIZE**

- 3/8 NPTF ..... 3
- 1/2 NPTF ..... 4
- 3/4 NPTF ..... 6
- 9/16-18 UNF SAE ..... S6
- 3/4-16 UNF SAE ..... S8
- 7/8-14 UNF SAE ..... S10

**PORT TYPE**

- NPTF Threads ..... Leave Blank
- BSPP threads ..... W

**OPTIONS** (More than one option can be chosen)

- Delete gauge ..... Leave Blank
- 0-160 PSI Gauge ..... G
- Plastic mounting nut ..... P
- Metal mounting nut..... PN
- Hex plastic mounting nut ..... PE

**OPTIONS** (More than one option can be chosen)

- None ..... Leave Blank

**Cap color:** Grey is standard.

- MP yellow .....C1
- Red .....C2
- Mid blue .....C3

**Springs:** (15-200 psig standard)

- For optimum performance operating pressure should fall approximately in the middle of the spring range.
- 15-250 psig (1-17 bar) .....H
  - 15-100 psig (1-7 bar) .....L

**MOUNTING BRACKETS**  
See page 276.

# Full-Size VANGUARD Modular Internally Piloted Precision Regulators

## IR100 Models Port Sizes: 1/4, 3/8, 1/2, 3/4



Model Shown: R100-6G

- ◆ Modular or inline mounting.
- ◆ Self-relieving diaphragm design.
- ◆ Easy finger adjustment. No overshoot or undershoot when adjusting.
- ◆ Constant air bleed for accuracy.
- ◆ Repeatability  $\pm 0.5$  psi ( $\pm 0.034$  bar).
- ◆ Pressure gauge.
- ◆ NPTF port threads; optional SAE or BSPP threads.

### SPECIFICATIONS

**Ambient/Media Temperature:**

40° to 125°F (4° to 52°C).

**Body and Dome:** Zinc.

**Bonnet and Knob:** Acetal.

**Constant Air Bleed Rate:** 0.18 – 0.33 scfm at 80 psi secondary pressure

**Fluid Media:** Compressed air.

**Inlet Pressure:** 250 psig (17 bar) maximum.

**Outlet Pressure:** Adjustable 15 – 200 psig (1 – 14 bar).

**Pressure Gauge:** 0 to 200 psig (14 bar); 1/4 NPT gauge ports front and rear.

**Panel Mounting:** 1-3/16 (30 mm) hole required.

**Seals:** Nitrile.

**Self-relieving**

**Valve:** Brass.

### FLOW CHART

Inlet Pressure: 100 psig (7 bar)

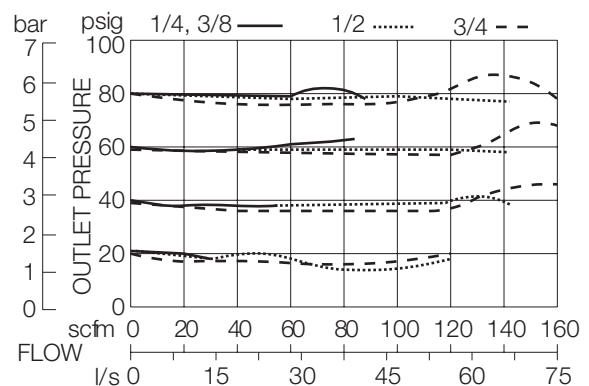



**DIMENSIONS inches (mm)**

A	B	C	Depth †	Weight † lb (kg)
3.5 (89)	4.2 (106)	1.3 (33)	2.8 (71)	2.06 (0.92)

† Less gauge.

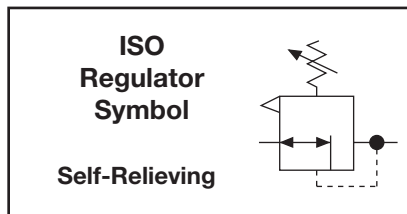
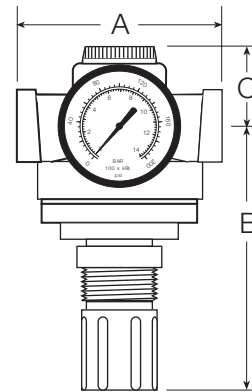

**ORDERING INFORMATION**

Change the letters in the sample model number below to specify the regulator you want.

**IR100 - 2 Y G W**

**PORT SIZE**

- 1/4 NPTF..... 2
- 3/8 NPTF..... 3
- 1/2 NPTF..... 4
- 3/4 NPTF..... 6
- 9/16-18 UNF SAE ..... S6
- 3/4-16 UNF SAE ..... S8
- 7/8-14 UNF SAE ..... S10

**PORT TYPE**

- NPTF Threads ..... Leave Blank
- BSPP threads ..... W

**OPTIONS** (More than one option can be chosen)

- Delete gauge ..... Leave Blank
- 0-160 PSI Gauge ..... G
- Plastic mounting nut ..... P
- Metal mounting nut..... PN
- Hex plastic mounting nut ..... PE

**OPTIONS** (More than one option can be chosen)

- None.....Leave Blank
- 1.75-inch (4.5 cm) diameter adjusting knob with removable locking key.....B
- Springs: (15-200 psig standard)
- For optimum performance operating pressure should fall approximately in the middle of the spring range.
- 15-250 psig (1-17 bar) .....H
- 15-100 psig (1-7 bar) .....L

**MOUNTING BRACKETS**

See page 276.

# High-Capacity VANGUARD Internally Piloted Precision Regulators

## IR180M Models Port Sizes: 3/4, 1, 1-1/4, 1-1/2



Model Shown: IR180M-6G

### SPECIFICATIONS

**Ambient/Media Temperature:**

40° to 175°F (4° to 79°C).

**Body:** Aluminum.

**Bonnet and Knob:** Acetal.

**Constant Air Bleed Rate:** 0.18 – 0.33 scfm at 80 psi secondary pressure

**Dome:** Zinc.

**Fluid Media:** Compressed air.

**Inlet Pressure:** 300 psig (21 bar) maximum.

**Outlet Pressure:**

Adjustable 15 to 200 psig (1 to 14 bar).

**Pressure Gauge:** 0 to 200 psig (14 bar); 1/4 NPT gauge ports front and rear.

**Panel Mounting:** 1-3/16 (30 mm) hole required.

**Seals:** Nitrile.

**Self-relieving**

**Valve:** Brass.

**Valve Cap:** Nylon.

- ◆ Inline mounting.
- ◆ Diaphragm-type design.
- ◆ Self-relieving.
- ◆ Constant air bleed for accuracy.
- ◆ Repeatability  $\pm 0.5$  psi ( $\pm 0.034$  bar).
- ◆ Pressure gauge.
- ◆ NPTF port threads; optional SAE or BSPP threads.

### FLOW CHART

Inlet Pressure: 91 psig (6.3 bar)

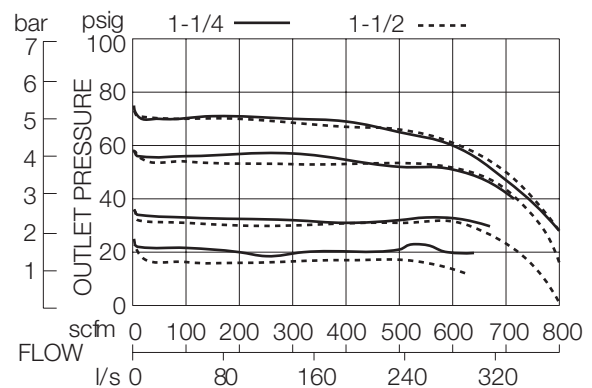
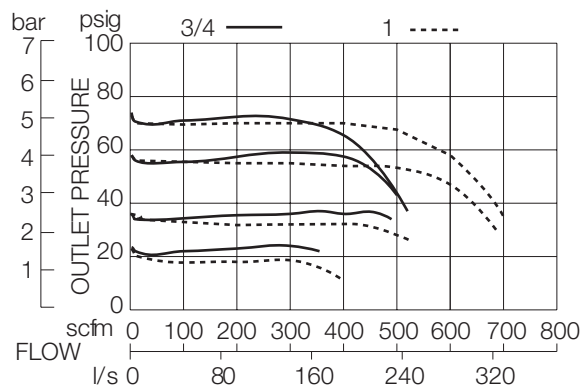

**DIMENSIONS** inches (mm)

Ports	A	B	C	Depth †	Weight † lb (kg)
3/4 1	4.4 (111)	4.6 (112)	2.4 (62)	2.8 (71)	2.0 (0.91)
1-1/4 1-1/2	4.9 (124)	4.9 (125)	2.1 (54)	2.8 (71)	2.38 (1.08)

† Less gauge.

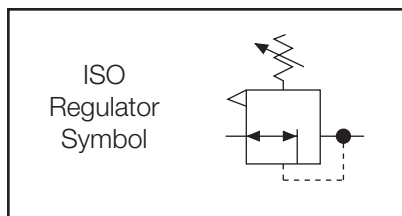
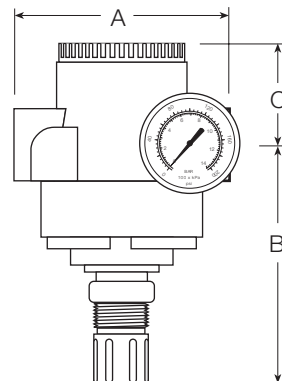

**ORDERING INFORMATION**

Change the letters in the sample model number below to specify the regulator you want.

**IR180M - 6 Y G W**

**PORT SIZE**

- 3/4 NPTF..... 6
- 1 NPTF ..... 8
- 1-1/4 NPTF ..... 10
- 1-1/2 NPTF ..... 12
- 1-1/16-12 UNF SAE ..... S12
- 1-5/16-12 UNF SAE ..... S16
- 1-5/8-12 UNF SAE ..... S20
- 1-7/8-12 UNF SAE ..... S24

**PORT TYPE**

- NPTF Threads ..... Leave Blank
- BSPF threads ..... W

**OPTIONS** (*More than one option can be chosen*)

- Delete gauge ..... Leave Blank
- 0-160 PSI Gauge ..... G
- Plastic mounting nut ..... P
- Metal mounting nut..... PN
- Hex plastic mounting nut ..... PE

**OPTIONS** (*More than one option can be chosen*)

- None..... Leave Blank
- 1.75-inch (4.5 cm) diameter  
adjusting knob with  
removable locking key .....B
- Springs: (15-200 psig standard)  
For optimum performance operating  
pressure should fall approximately in  
the middle of the spring range.
- 15-250 psig (1-17 bar) .....H
- 15-100 psig (1-7 bar) .....L

**MOUNTING BRACKETS**  
See page 276.

# MINIATURE Externally Piloted Regulators

# PR55M, PR56M Models Port Sizes: 1/8, 1/4



Model Shown: PR56M-1G

- ◆ Inline mounting.
- ◆ Piston-type design (**PR55M** models) or diaphragm-type design (**PR56M** models)
- ◆ Self-relieving; non-relieving optional.
- ◆ Pressure gauge.
- ◆ **NPTF** port threads; optional **BSPP** threads.

## SPECIFICATIONS

**Ambient/Media Temperature:**

40° to 125°F (4° to 52°C).

**Body and Dome:** Aluminum.

**Fluid Media:** Compressed air.

**Inlet Pressure:** 300 psig (21 bar) maximum.

**Outlet Pressure:** Adjustable up to 125 psig (8.6 bar).

**Pressure Gauge:** 0 to 160 psig (10.3 bar); 1/8 NPT gauge ports front and rear.

**Seals:** Nitrile.

## FLOW CHART

Inlet Pressure: 91 psig (6.3 bar)

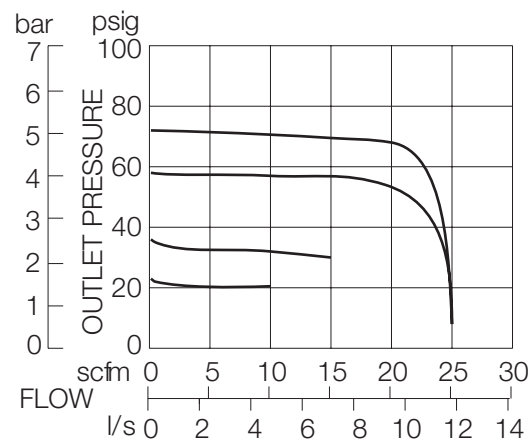

**DIMENSIONS** inches (mm)

A	B	C	Depth	Weight lb (kg)
1.6 (41)	1.8 (46)	0.38 (9.5)	1.6 (41)	0.25 (0.11)

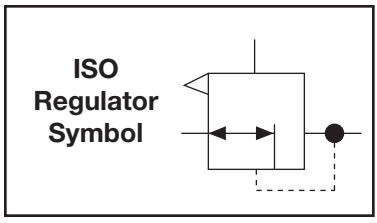
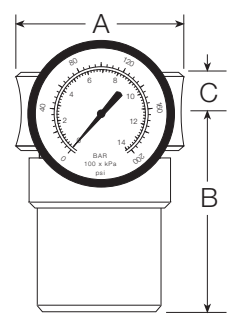

**ORDERING INFORMATION**

Change the letters in the sample model number below to specify the regulator you want.

**PR56M - 2 Y G W**

**REGULATOR TYPE**  
 Piston ..... PR55M  
 Diaphragm ..... PR56M

**PORT SIZE**  
 1/8 NPTF..... 1  
 1/4 NPTF..... 2

**OPTIONS**  
 None..... Leave Blank  
 Non-relieving ..... A

**PORT TYPE**  
 NPTF Threads ..... Leave Blank  
 BSP threads ..... W

**GAUGE**  
 None ..... Leave Blank  
 0-160 PSI Gauge ..... G

**No mounting bracket available.**

# Full-Size SERIES 380 Modular Externally Piloted Regulators

# PR380 Models Port Sizes: 3/8, 1/2, 3/4

## Available Color Caps

Yellow  
(optional)



Red  
(optional)



Blue  
(optional)



Grey  
(standard)



Model Shown: PR380-6G

- ◆ Modular or inline mounting.
- ◆ Self-relieving diaphragm design.
- ◆ Pressure gauge.
- ◆ NPTF port threads; optional SAE or BSPP threads.

## SPECIFICATIONS

**Ambient/Media Temperature:**

40° to 175°F (4° to 79°C).

**Body:** Zinc.

**Dome:** Zinc.

**Fluid Media:** Compressed air.

**Inlet Pressure:** 300 psig (21 bar) maximum.

**Outlet Pressure:** Adjustable 0 – 250 psig (0 – 17 bar).

**Pilot Ports:** 1/4 NPTF

**Pressure Gauge:** 0 to 200 psig (14 bar); 1/4 NPT gauge ports front and rear.

**Seals:** Nitrile.

**Valve:** Brass.

**Valve Cap:** Nylon.

## FLOW CHARTS

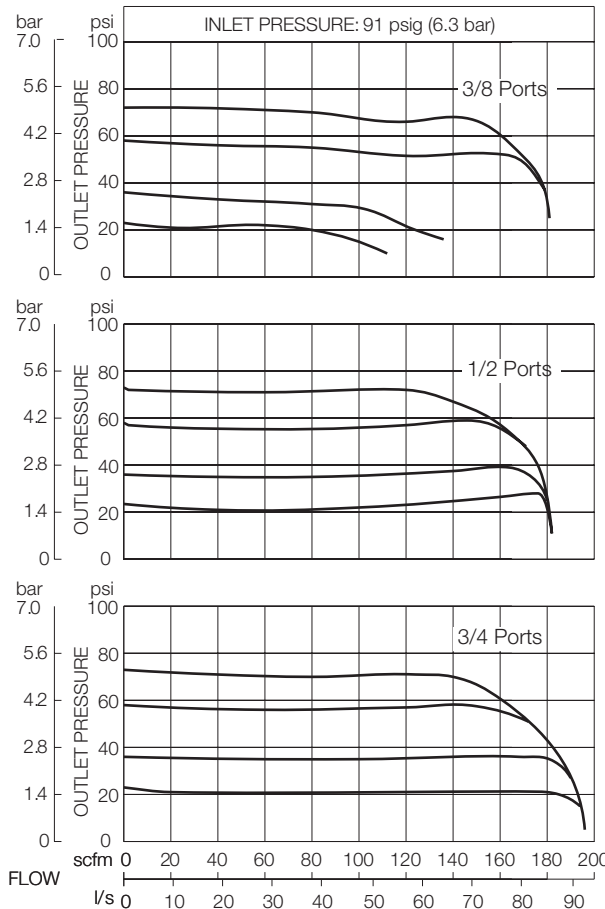

**DIMENSIONS** inches (mm)

A	B	C	Depth †	Weight † lb (kg)
3.5 (87)	2.4 (62)	1.6 (40)	2.9 (73)	2.20 (1.00)

† Less gauge.

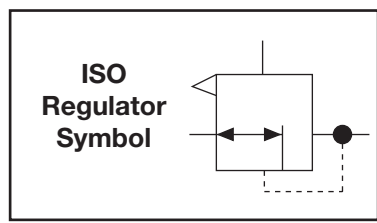
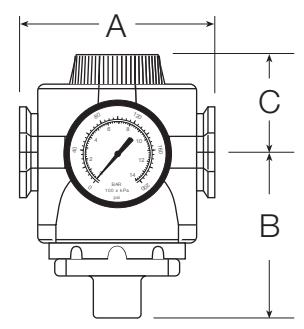

**ORDERING INFORMATION**

Change the letters in the sample model number below to specify the regulator you want.

**NOTE:** Order a pilot operator such as **R55-2**, **R56-2**, or **IR100-2** separately.

**PR380 - 3 Y G W**

- PORT SIZE**
- 3/8 NPTF..... 3
  - 1/2 NPTF..... 4
  - 3/4 NPTF..... 6
  - 9/16-18 UNF SAE ..... S6
  - 3/4-16 UNF SAE ..... S8
  - 7/8-14 UNF SAE ..... S10

- PORT TYPE**
- NPTF Threads ..... Leave Blank
  - BSP threads ..... W

- OPTIONS**
- None ..... Leave Blank
  - 0-200 PSI Gauge ..... G

- OPTIONS (More than one option can be chosen)**
- None ..... Leave Blank
  - Non-relieving ..... A
  - Cap Color: Grey is standard
  - MP yellow ..... C1
  - Red ..... C2
  - Mid blue ..... C3

**MOUNTING BRACKETS**  
See page 276.

# Full-Size VANGUARD Modular Externally Piloted Regulators

# PR100 Models Port Sizes: 1/4, 3/8, 1/2, 3/4



Model Shown: PR100-6G

- ◆ Modular or inline mounting.
- ◆ Self-relieving diaphragm design.
- ◆ Pressure gauge.
- ◆ NPTF port threads; optional SAE or BSPP threads.

## SPECIFICATIONS

**Ambient/Media Temperature:**

40° to 175°F (4° to 79°C).

**Body:** Zinc.

**Dome:** Zinc.

**Fluid Media:** Compressed air.

**Inlet Pressure:** 300 psig (21 bar) maximum.

**Outlet Pressure:** Adjustable 0 – 200 psig (0 – 14 bar).

**Pilot Ports:** 1/4 NPTF

**Pressure Gauge:** 0 to 200 psig (14 bar); 1/4 NPT gauge ports front and rear.

**Seals:** Nitrile.

**Valve:** Brass.

**Valve Cap:** Nylon.

## FLOW CHARTS

Inlet Pressure: 100 psig (7 bar)

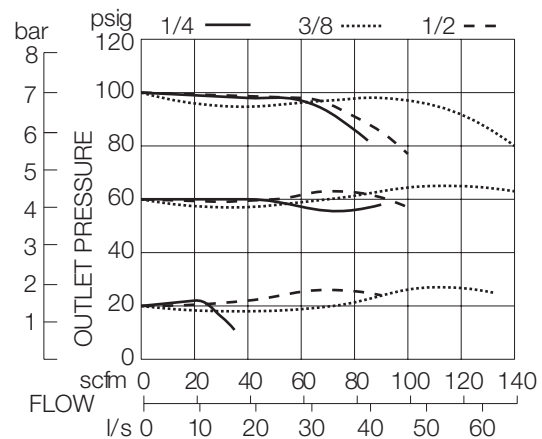



**DIMENSIONS** inches (mm)

A	B	C	Depth †	Weight † lb (kg)
3.5 (89)	2.4 (62)	1.3 (33)	2.8 (71)	2.06 (0.92)

† Less gauge.

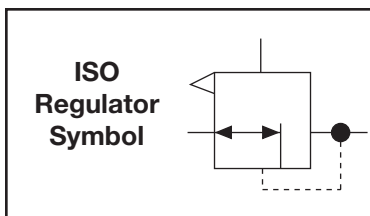
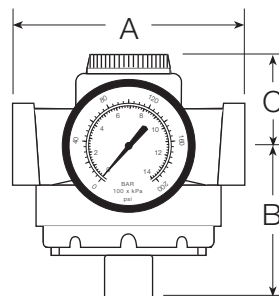

**ORDERING INFORMATION**

Change the letters in the sample model number below to specify the regulator you want.

**NOTE:** Order a pilot operator such as **R55-2**, **R56-2**, or **IR100-2** separately.

**PR100 - 2 Y G W**

**PORT SIZE**

- 1/4 NPTF..... 2
- 3/8 NPTF..... 3
- 1/2 NPTF..... 4
- 3/4 NPTF..... 6
- 9/16-18 UNF SAE ..... S6
- 3/4-16 UNF SAE ..... S8
- 7/8-14 UNF SAE ..... S10

**PORT TYPE**

- NPTF Threads ..... Leave Blank
- BSPP threads ..... W

**OPTION**

- None ..... Leave Blank
- 0-200 PSI Gauge ..... G

**OPTION**

- None ..... Leave Blank
- Non-relieving ..... A

**MOUNTING BRACKETS**  
See page 276.

# Full-Size VANGUARD Modular High-Relief Externally Piloted Regulators

## PRH100 Models Port Sizes: 1/4, 3/8, 1/2, 3/4



Model Shown: PRH100-6G

### SPECIFICATIONS

**Ambient/Media Temperature:**

40° to 175°F (4° to 79°C).

**Body:** Zinc.

**Dome:** Zinc.

**Fluid Media:** Compressed air.

**Inlet Pressure:** 300 psig (21 bar) maximum.

**Outlet Pressure:** Adjustable 0 – 200 psig (0 – 14 bar).

**Pilot Ports:** 1/4 NPTF

**Pressure Gauge:** 0 to 200 psig (14 bar); 1/4 NPT gauge ports front and rear.

**Seals:** Nitrile; optional Viton seals.

**Valve:** Brass.

**Valve Cap:** Nylon.

High-Relief valves separate control air from exhaust air.

- ◆ Modular or inline mounting.
- ◆ Diaphragm-type design.
- ◆ Self-relieving.
- ◆ Pressure gauge.
- ◆ **NPTF** port threads; optional **SAE** or **BSPP** threads.

### FLOW CHARTS

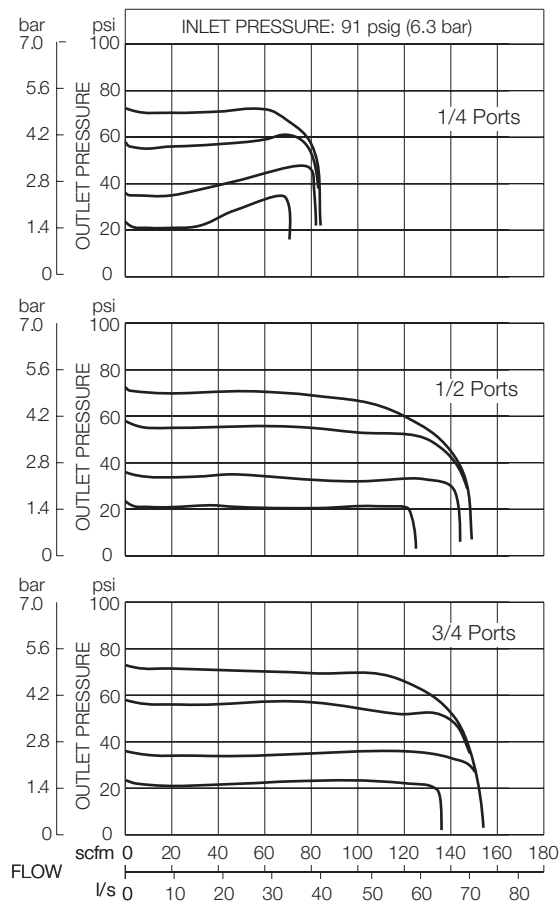

**DIMENSIONS** inches (mm)

A	B	C	Depth †	Weight † lb (kg)
3.5 (89)	2.4 (62)	1.3 (33)	2.8 (71)	2.06 (0.92)

† Less gauge.

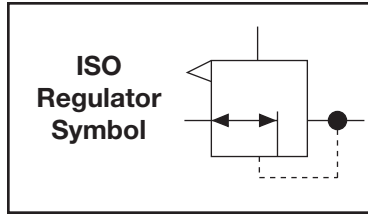
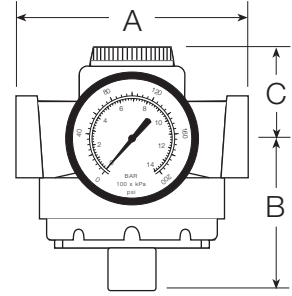

**ORDERING INFORMATION**

Change the letters in the sample model number below to specify the regulator you want.

**NOTE:** Order a pilot operator such as **R55-2**, **R56-2**, or **IR100-2** separately.

**PRH100 - 2 Y G W**

**PORT SIZE**

- 1/4 NPTF..... 2
- 3/8 NPTF..... 3
- 1/2 NPTF..... 4
- 3/4 NPTF..... 6
- 9/16-18 UNF SAE ..... S6
- 3/4-16 UNF SAE ..... S8
- 7/8-14 UNF SAE ..... S10

**PORT TYPE**

- NPTF Threads ..... Leave Blank
- BSPP threads ..... W

**OPTION**

- None ..... Leave Blank
- 0-200 PSI Gauge ..... G

**OPTION**

- None ..... Leave Blank
- Viton seals..... V

**MOUNTING BRACKETS**  
See page 276.

# High-Capacity VANGUARD Externally Piloted Regulators

# PR180M Models Port Sizes: 3/4, 1, 1-1/4, 1-1/2



Model Shown: PR180M-6G

- ◆ Inline mounting.
- ◆ Diaphragm-type design.
- ◆ Self-relieving.
- ◆ Pressure gauge.
- ◆ NPTF port threads; optional SAE or BSPP threads.

## SPECIFICATIONS

**Ambient/Media Temperature:**

40° to 175°F (4° to 79°C).

**Body:** Aluminum.

**Dome:** Zinc.

**Fluid Media:** Compressed air.

**Inlet Pressure:** 300 psig (21 bar) maximum.

**Outlet Pressure:** 0 to 200 psig (0 to 14 bar).

**NOTE:** Outlet pressure depends on the selection of the pilot regulator.

**Pilot Ports:** 1/4 NPTF.

**Pressure Gauge:** 0 to 200 psig (14 bar); 1/4 NPT gauge ports front and rear.

**Seals:** Nitrile.

**Valve:** Brass.

**Valve Cap:** Nylon.

## FLOW CHART

Inlet Pressure: 100 psig (7 bar)

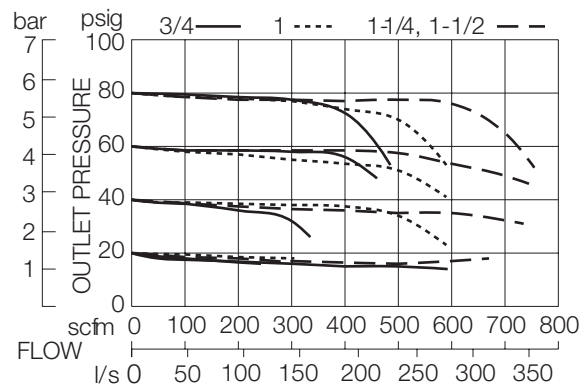

**DIMENSIONS** inches (mm)

Ports	A	B	C	Depth †	Weight † lb (kg)
3/4 1	4.4 (111)	4.6 (112)	2.4 (62)	2.8 (71)	1.88 (0.85)
1-1/4 1-1/2	4.9 (124)	5.1 (129)	2.1 (54)	2.8 (71)	2.25 (1.02)

† Less gauge.

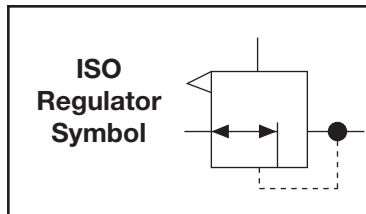
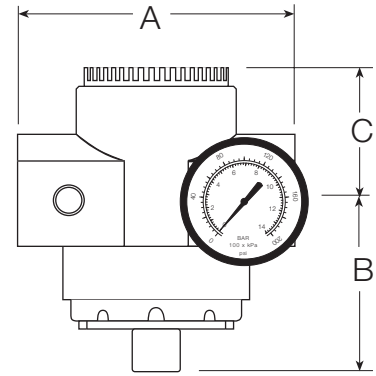

**ORDERING INFORMATION**

Change the letters in the sample model number below to specify the regulator you want.

**NOTE:** Order a pilot operator such as **R55-2**, **R56-2**, or **IR100-2** separately.

**PR180M - 6 Y G W**

**PORT SIZE**

- 3/4 NPTF..... 6
- 1 NPTF ..... 8
- 1-1/4 NPTF ..... 10\*
- 1-1/2 NPTF ..... 12\*
- 1-1/16-12 UNF SAE ..... S12
- 1-5/16-12 UNF SAE ..... S16
- 1-5/8-12 UNF SAE ..... S20
- 1-7/8-12 UNF SAE ..... S24

**PORT TYPE**

- NPTF Threads ..... Leave Blank
- BSP threads ..... W

**OPTION**

- None ..... Leave Blank
- 0-200 PSI Gauge ..... G

**OPTION**

- None ..... Leave Blank
- Non-relieving ..... A

**MOUNTING BRACKETS**  
See page 276.

\* No mounting bracket available.

# High-Capacity VANGUARD High-Relief Externally Piloted Regulators

## PRH180M Models Port Sizes: 3/4, 1, 1-1/4, 1-1/2



Model Shown: PRH180M-8G

### SPECIFICATIONS

**Ambient/Media Temperature:**

40° to 175°F (4° to 79°C).

**Body:** Aluminum.

**Dome:** Zinc.

**Fluid Media:** Compressed air.

**Inlet Pressure:** 300 psig (21 bar) maximum.

**Outlet Pressure:** 0 to 200 psig (0 to 14 bar).

**Pilot Ports:** 1/4 NPTF.

**Pressure Gauge:** 0 to 200 psig (14 bar); 1/4 NPT gauge ports front and rear.

**Seals:** Nitrile.

**Valve:** Brass.

**Valve Cap:** Nylon.

High-Relief valves separate control air from exhaust air.

- ◆ Inline mounting.
- ◆ Diaphragm-type design.
- ◆ Self-relieving.
- ◆ Pressure gauge.
- ◆ NPTF port threads; optional SAE or BSPP threads.

### FLOW CHARTS

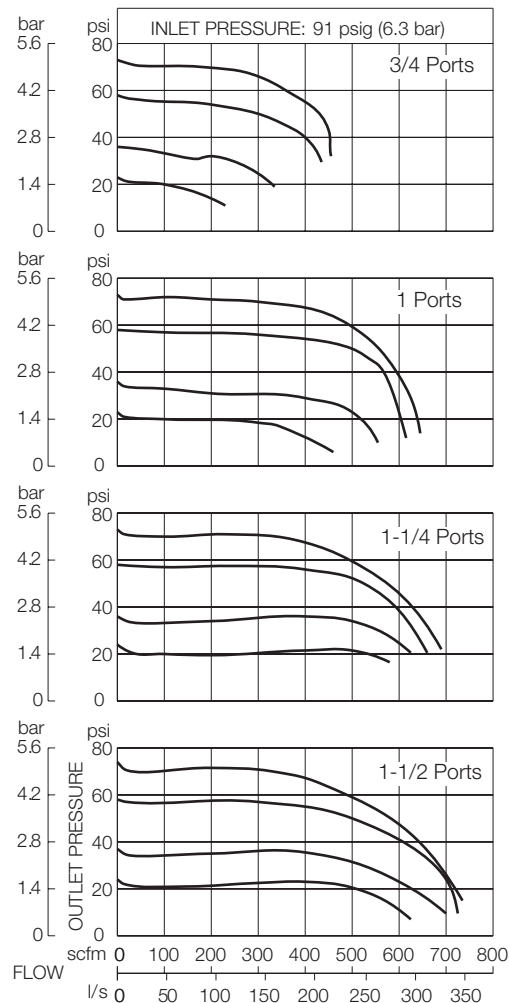

**DIMENSIONS** inches (mm)

Ports	A	B	C	Depth †	Weight † lb (kg)
3/4	4.4	4.6	2.4	2.8	1.88
1	(111)	(112)	(62)	(71)	(0.85)
1-1/4	4.9	5.1	2.1	2.8	2.25
1-1/2	(124)	(129)	(54)	(71)	(1.02)

† Less gauge.

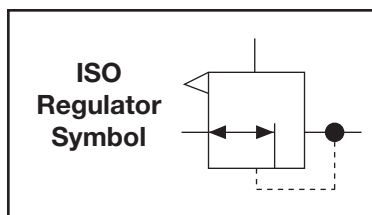
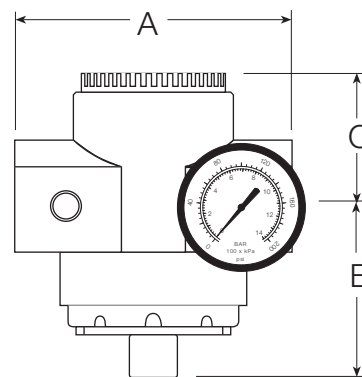

**ORDERING INFORMATION**

Change the letters in the sample model number below to specify the regulator you want.

**NOTE:** Order a pilot operator such as **R55-2**, **R56-2**, or **IR100-2** separately.

**PRH180M - 6 G W**

**PORT SIZE**

- 3/4 NPTF..... 6
- 1 NPTF ..... 8
- 1-1/4 NPTF ..... 10\*
- 1-1/2 NPTF ..... 12\*
- 1-1/16-12 UNF SAE ..... S12
- 1-5/16-12 UNF SAE ..... S16
- 1-5/8-12 UNF SAE ..... S20
- 1-7/8-12 UNF SAE ..... S24

**PORT TYPE**

- NPTF Threads ..... Leave Blank
- BSPP threads ..... W

**OPTION**

- None ..... Leave Blank
- 0-200 PSI Gauge ..... G

**MOUNTING BRACKETS**  
See page 276.

\* No mounting bracket available.

# High-Capacity VANGUARD Externally Piloted Regulators

# R200 Models Port Sizes: 1-1/2, 2



Model Shown: R200-12G

- ◆ Inline mounting.
- ◆ Piston-type design.
- ◆ Self-relieving.
- ◆ Pressure gauge.
- ◆ NPTF port threads; optional SAE or BSPP threads.

## SPECIFICATIONS

**Ambient/Media Temperature:**

40° to 175°F (4° to 79°C).

**Body and Dome:** Aluminum.

**Fluid Media:** Compressed air.

**Inlet Pressure:** 300 psig (21 bar) maximum.

**Outlet Pressure:** 0 to 200 psig (0 to 14 bar).

**NOTE:** Outlet pressure depends on the selection of the pilot regulator.

**Pilot Ports:** 1/4 NPTF.

**Pressure Gauge:** 0 to 200 psig (14 bar); 1/4 NPT gauge ports front and rear.

**Seals:** Nitrile; optional Viton seals.

**Valve:** Brass.

**Valve Cap:** Aluminum.

## FLOW CHART

Inlet Pressure: 91 psig (6.3 bar)

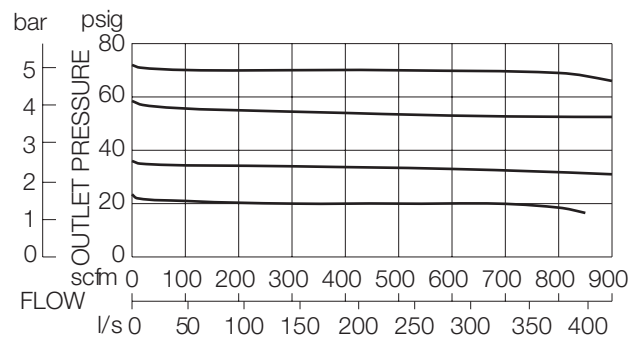



**DIMENSIONS** inches (mm)

A	B	C	Depth †	Weight † lb (kg)
6.4 (162)	5.0 (127)	3.0 (76)	2.8 (71)	8.94 (4.06)

† Less gauge.

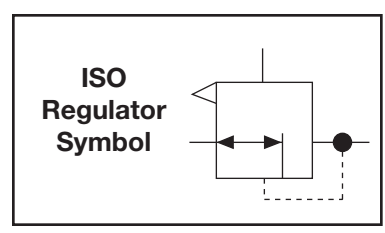
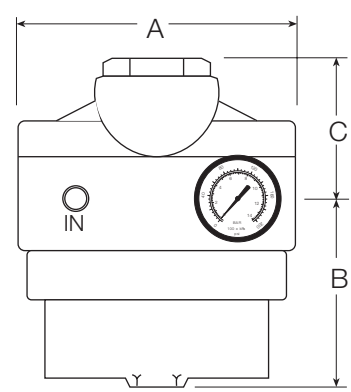

**ORDERING INFORMATION**

Change the letters in the sample model number below to specify the regulator you want.

**NOTE:** Order a pilot operator such as R55-2, R56-2, or IR100-2 separately.

**R200 - 12 Y G W**

**PORT SIZE**

- 1-1/2 NPTF ..... 12
- 2 NPTF ..... 16
- 1-7/8-12 UNF SAE ..... S24
- 2-1/2-12 UNF SAE ..... S32

**PORT TYPE**

- NPTF Threads ..... Leave Blank
- BSPF threads ..... W

**OPTIONS** (More than one option can be chosen)

- None ..... Leave Blank
- Non-relieving ..... A
- Constant bleed ..... Q
- Viton seals ..... V

**OPTION**

- None ..... Leave Blank
- 0-200 PSI Gauge ..... G

**MOUNTING BRACKETS**  
See page 276.

# SENTRY Acetal-Body Water Pressure Regulators

Also see brass-body water pressure regulators on pages 156-157.

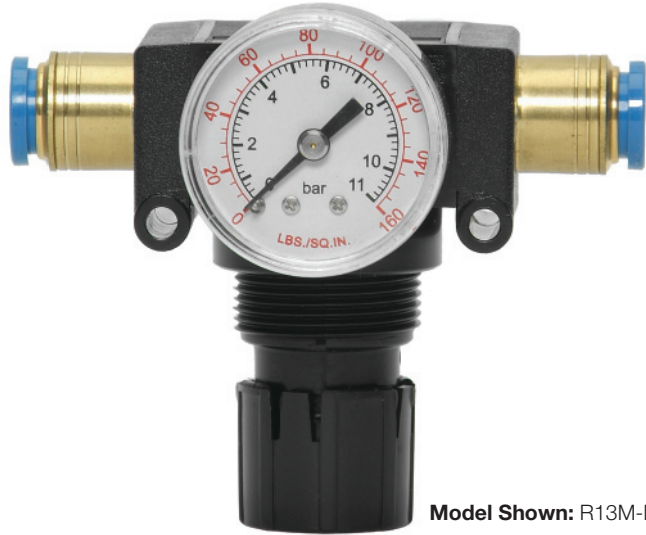

Model Shown: R13M-M10

# R13M, R14M Models Port Sizes: 1/8, 1/4; Tube Fittings

- ◆ Designed to set pilot pressure of the water for the main valve in a sprinkler system. See diagram below.
- ◆ Piston-type design (**R13M** models) or diaphragm-type (**R14M** models).
- ◆ Non-relieving.
- ◆ Corrosion-resistant construction.
- ◆ Optional large valve seat for water flows up to six gallons per minute.
- ◆ Threaded ports or quick-connect fittings for tubing up to 10 mm in diameter.
- ◆ **NPTF** port threads; optional **BSPP** threads.

## TYPICAL APPLICATION IN AN IRRIGATION SYSTEM

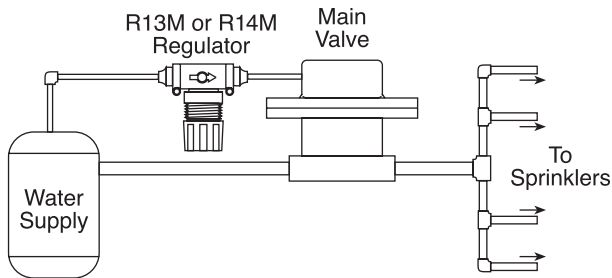

## SPECIFICATIONS

### Ambient/Media Temperature:

35° to 125°F (1.7° to 52°C).

**Body:** Acetal.

**Dome and Knob:** Acetal.

**Fluid Media:** Water.

**Inlet Pressure:** 150 psig (10 bar) maximum.

**Main Spring:** Music wire.

**Outlet Pressure:** Adjustable up to 100 psig (7 bar); locking adjustment cap.

**Panel Mounting:** 1-3/16 inch (30 mm) hole required.

**Pressure Gauge:** Optional (0-160 psig).

**Seals:** Nitrile.

## WATER FLOW CHARTS

Inlet Pressure: 100 psig (7 bar)

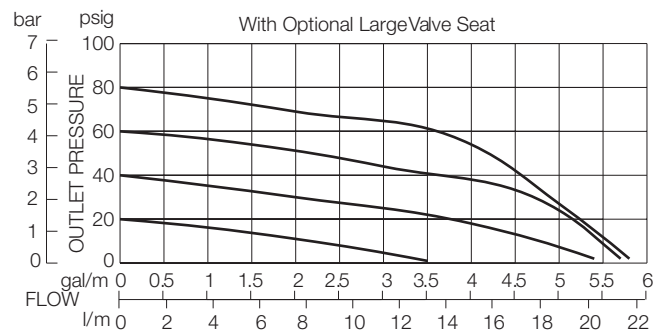
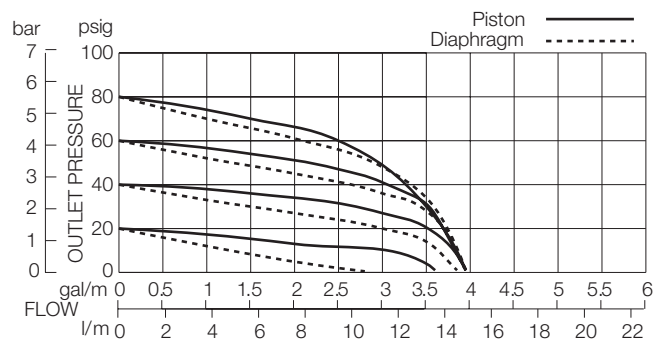

## DIMENSIONS inches (mm)

Ports	A	B	C	Depth	Weight lb (kg)
1/8, 1/4	3.0 (76)	2.6 (67)	0.5 (13)	1.8 (45)	0.43 (0.19)
Models below have quick-connect fittings for tubing.					
1/4	3.4 (86)	2.6 (67)	0.5 (13)	1.8 (45)	0.21 (0.09)
3/8	3.9 (99)	2.6 (67)	0.5 (13)	1.8 (45)	0.21 (0.09)
4 mm	3.4 (86)	2.6 (67)	0.5 (13)	1.8 (45)	0.41 (0.18)
6 mm	3.4 (86)	2.6 (67)	0.5 (13)	1.8 (45)	0.41 (0.18)
8 mm	3.1 (79)	2.6 (67)	0.5 (13)	1.8 (45)	0.41 (0.18)
10 mm	3.9 (99)	2.6 (67)	0.5 (13)	1.8 (45)	0.41 (0.18)

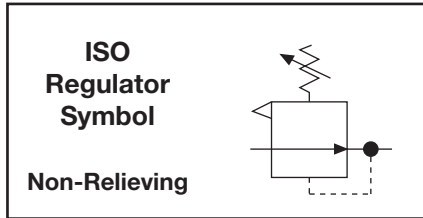
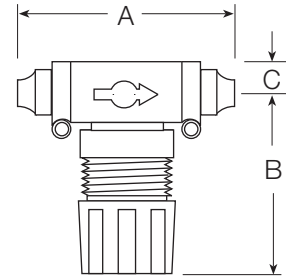

### ORDERING INFORMATION

Change the letters in the sample model number below to specify the regulator you want.

## R13M P - 2 X A Y G

#### REGULATOR TYPE

Piston type .....R13M  
Diaphragm type.....R14M

#### MOUNTING HOLE LOCATION

Bottom mount (Standard) ..... Leave Blank  
Top mount ..... P

#### INLET PORT SIZE

No Inlet and Outlet Ports .... Leave Blank

#### Threaded:

1/8 NPTF ..... 1  
1/4 NPTF ..... 2

#### Fittings for Tubing:

1/4 ..... 04  
3/8 ..... 06  
4 mm ..... M4  
6 mm ..... M6  
8 mm ..... M8  
10 mm ..... M10

#### OUTLET PORT SIZE

Same as inlet port ..... Leave Blank

#### Threaded:

1/8 NPTF ..... 1  
1/4 NPTF ..... 2

#### Fittings for Tubing:

1/4 ..... 04  
3/8 ..... 06  
4 mm ..... M4  
6 mm ..... M6  
8 mm ..... M8  
10 mm ..... M10

#### PORT TYPE

As specified in **INLET PORT** ... Leave Blank  
BSPP threads on both ports..... W

#### OPTIONS (More than one option can be chosen)

None ..... Leave Blank  
0-160 psig Gauge ..... G  
Plastic nut ..... P  
Hex plastic nut..... PE  
Metal Panel Mount Nut ..... PN

#### OPTIONS (More than one option can be chosen)

None. .... Leave Blank  
Large Delrin valve seat..... C1  
Springs: (0-100 psig standard)  
For optimum performance operating pressure should fall approximately in the middle of the spring range.  
0-125 psig (0-8.6 bar) ..... H  
0-50 psig (0-3.4 bar) ..... L  
0-30 psig (0-2.1 bar) ..... L30  
Rear gauge port only ..... R

#### MOUNTING BRACKETS

See page 276.

# MINIATURE Brass-Body Water Pressure Regulators

Also see acetal-body water pressure regulators on pages 154-155.



Model Shown: R53MB-2G

# R53MB, R54MB Models Port Sizes: 1/8, 1/4

- ◆ Inline mounting.
- ◆ Piston-type design (R53MB models) or diaphragm-type (R54MB models).
- ◆ Optional large valve seat for water flows up to 6 gallons per minute.
- ◆ Non-relieving.
- ◆ Brass body for corrosion resistance.
- ◆ Pressure gauge.
- ◆ NPTF port threads; optional BSPP threads.

## SPECIFICATIONS

### Ambient/Media Temperature:

40° to 125°F (4° to 52°C).

**Body:** Brass.

**Dome and Knob:** Acetal.

**Fluid Media:** Water

**Inlet Pressure:** 300 psig (21 bar) maximum.

**Main Spring:** Music wire.

**Outlet Pressure:** Adjustable up to 100 psig (7 bar).

**Pressure Gauge:** 0 to 160 psig (10.3 bar); 1/8 NPT gauge ports front and rear.

**Panel Mounting:** 1-3/16 inch (30 mm) hole required.

**Seals:** Nitrile.

## WATER FLOW CHARTS

Inlet Pressure: 100 psig (7 bar)

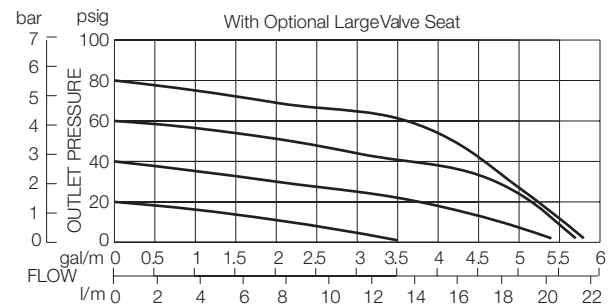
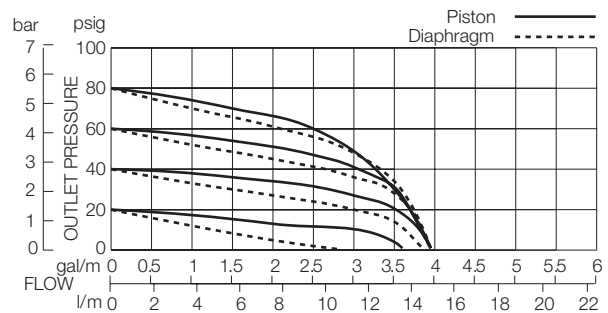

**DIMENSIONS** inches (mm)

A	B	C	Depth †	Weight † lb (kg)
1.6 (41)	2.7 (68)	0.4 (10)	1.6 (41)	0.24 (0.11)

† Less gauge.

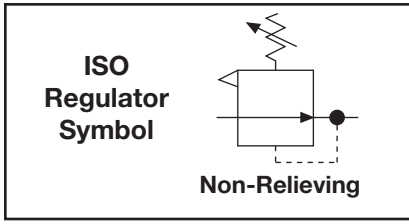
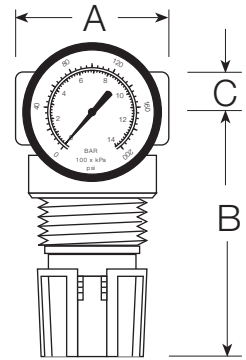

**ORDERING INFORMATION**

Change the letters in the sample model number below to specify the regulator you want.

**R53MB - 2 A Y G W**

**REGULATOR TYPE**

- Piston type ..... R53MB
- Diaphragm type ..... R54MB

**PORT SIZE**

- 1/8 NPTF ..... 1
- 1/4 NPTF ..... 2

**PORT TYPE**

- NPTF Threads ..... Leave Blank
- BSPB threads ..... W

**OPTIONS** (More than one option can be chosen)

- None ..... Leave Blank
- 0-160 psig Gauge ..... G
- Plastic nut ..... P
- Hex plastic nut ..... PE
- Metal mounting nut ..... PN

**OPTIONS** (More than one option can be chosen)

- None ..... Leave Blank
- Large Delrin valve seat ..... C1
- Springs: (0-100 psig standard)

For optimum performance operating pressure should fall approximately in the middle of the spring range.

- 0-125 psig (0-8.6 bar) ..... H
- 0-50 psig (0-3.4 bar) ..... L
- 0-30 psig (0-2.1 bar) ..... L30

Rear gauge port only ..... R

**MOUNTING BRACKETS**  
See page 276.

# MINIATURE Relief Valves

# RV56 Models Port Sizes: 1/8, 1/4



Model Shown: RV56-2G

- ◆ Inline mounting.
- ◆ Diaphragm-type design.
- ◆ Pressure gauge.
- ◆ NPTF port threads; optional BSPP threads.

## SPECIFICATIONS

**Ambient/Media Temperature:**

40° to 125°F (4° to 52°C).

**Body:** Aluminum.

**Dome and Knob:** Acetal.

**Fluid Media:** Compressed air.

**Relieving Range:** 1 to 100 psig (0.07 to 6.9 bar).

**Maximum Relief Flow Range:**

10 to 30 scfm (4.7 to 14 l/s) with a pressure differential of 10 to 15 psi (0.7 to 1 bar).

**Minimum Relief Flow:** 5 ml/minute.

**Pressure Gauge:** 0 to 160 psig (11 bar); 1-1/2 inch dial face; 1/8 NPT gauge ports front and rear.

**Panel Mounting:** 1-3/16 inch (30 mm) hole required.

**Seals:** Nitrile.

**Maximum Inlet Pressure:** 250 P.S.I.

## FLOW CHART

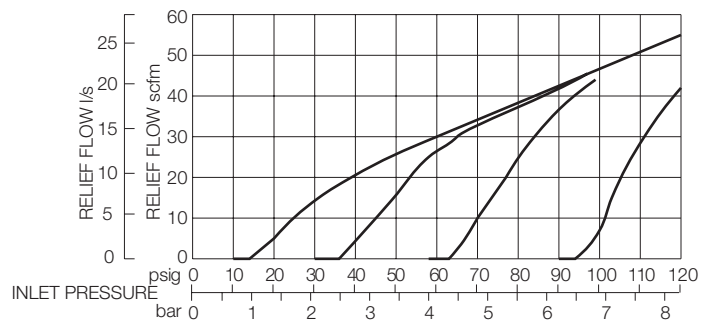

**DIMENSIONS inches (mm)**

A	B	C	Depth †	Weight † lb (kg)
1.6 (41)	2.7 (68)	0.4 (10)	1.6 (41)	0.38 (0.16)

† Less gauge.

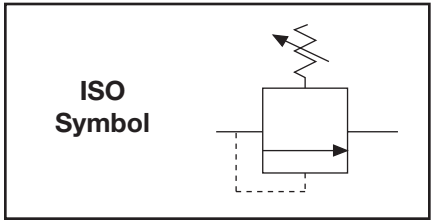
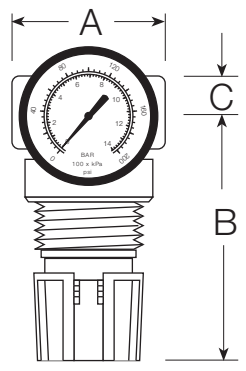

**ORDERING INFORMATION**

Change the letters in the sample model number below to specify the relief valve you want.

**RV56 - 2 Y G W**

**PORT SIZE**

- 1/8 NPTF..... 1
- 1/4 NPTF..... 2

**OPTIONS**

- None..... Leave Blank
- Springs: (0-100 psig standard)
  - For optimum performance operating pressure should fall approximately in the middle of the spring range.
  - 0-125 psig (0-8.6 bar) ..... H
  - 0-50 psig (0-3.4 bar) ..... L
  - 0-15 psig (0-1.0 bar) ..... L15
  - 0-30 psig (0-2.1 bar) ..... L30

**PORT TYPE**

- NPTF Threads ..... Leave Blank
- BSP threads ..... W

**OPTIONS** (*More than one option can be chosen*)

- Delete gauge ..... Leave Blank
- 0-160 PSI Gauge ..... G
- Plastic mounting nut ..... P
- Metal mounting nut..... PN
- Hex plastic mounting nut ..... PE

**MOUNTING BRACKETS**

See page 276.

Servo Valve



Model Shown: ER-1A2C200

Servo Valve with Booster



Model Shown: B2JA-ER-1A2C200

## SPECIFICATIONS

**Accuracy:**  $< \pm 2.5\%$  F.S.

**Analog Monitor Signal:**

**Voltage:** 0 – 10 VDC @ 20 ma maximum.

**Current:** 4 – 20 ma sinking (sourcing optional).

**Ambient/Media Temperature:**

32° to 158°F (0° to 70°C).

**Command Signal Impedance:**

**Voltage:** 4.7 k $\Omega$  . Current: 100  $\Omega$  .

**Command Signal Voltage/Current:**

0 – 10 VDC/4 – 20 ma.

**Electrical Connector:** 6-pin Brad Harrison.

**Fluid Media:** Compressed air.

**Housing:** Aluminum; black anodized finish.

**Input Pressure: Servo-valve With Regulator**

29.9 in Hg to 300 psig (760 mm Hg to 21 bar).

**Linearity/Hysteresis:**  $< \pm 2.0\%$  F.S. BFSL.

**Manifold:** Brass.

**Output Pressure:** 0 to 200 P.S.I..

**Repeatability:**  $< \pm 0.6\%$  F.S.

**Seals:** Fluorocarbon.

**Supply Voltage/Current:**

15 – 24 VDC/250 ma (required).

**Transducer:** Silicon, aluminum.

**Valves:** Nickel-plated brass.

**Note:** High-pressure servo-valve ( $\geq 150$  psi) - inlet and exhaust ports reversed from picture shown.

The Series ER servo valve is Master Pneumatic's latest product using closed loop control technology. It incorporates many important standard features.

Standard flow rate of the valve is typically one scfm maximum. When used with a volume booster a flow rate in excess of 1,000 scfm can be achieved.

Check the items below to see how cost-effective these valves can be in your plant.

- ◆ Fits into very small space.
- ◆ Accurate to  $\pm 2.5\%$  F.S.
- ◆ 0 – 10 VDC analog monitor output.
- ◆ NEMA 4 1P65 rating.
- ◆ Accepts analog command signal inputs.
- ◆ Servo-valve with regulator: control pressure ranges from vacuum to 300 psig.
- ◆ Valve is insensitive to shock, vibration, or mounting position.
- ◆ Easily repairable in the field.



## ORDERING INFORMATION for SERVO-VALVE ONLY

Change the letters in the sample model number below to specify the servo valve you want.

### ER-1 A 1 A 100

- CONNECTOR**  
6-Pin Brad Harrison..... A
- COMMAND INPUT**  
0-10 VDC..... 1  
4-20 ma..... 2
- MONITOR SIGNAL**  
0-10 VDC..... A  
4-20 ma - sinking..... B  
4-20 ma - sourcing..... C

- MAXIMUM CALIBRATED PRESSURE RANGE**  
0-30 psig ..... 030  
0-50 psig ..... 050  
0-100 psig ..... 100  
0-200 psig ..... 200  
0-300 psig ..... 300  
0-20 in Hg (vacuum)..... V20  
Consult Master Pneumatic for any other pressure ranges.

Brass Inlet Filter...37 - 288 (recommended when purchasing servo-valve only)

**NOTE:** Cable must be ordered separately. See choices below.

## ORDERING INFORMATION for SERVO-VALVE with VOLUME BOOSTER

Change the letters in the sample model number below to specify the servo valve you want.

### B 1 2 A-ER-1 A 1 A 100

- REGULATOR**  
PRH100 (1/4 to 3/4 ports)..... 1  
PRH180M (3/4 to 1-1/2 ports).... 2
- INLET/OUTLET PORTS**  
1/4 NPTF (PRH100 only)..... 2  
3/8 NPTF (PRH100 only)..... 3  
1/2 NPTF (PRH100 only)..... 4  
3/4 NPTF (PRH100 & PRH180M)..... 6  
1 NPTF (PRH180M only) ..... 8  
1-1/4 NPTF (PRH180M only) .....J  
1-1/2 NPTF (PRH180M only) ..... K  
1/4 BSPP (PRH100 only) ..... B  
3/8 BSPP (PRH100 only) ..... C  
1/2 BSPP (PRH100 only) ..... D  
3/4 BSPP (PRH100 & PRH 180M) ..... E  
1 BSPP (PRH180M only).....F  
1-1/4 BSPP (PRH180M only)..... G  
1-1/2 BSPP (PRH180M only)..... H

- MAXIMUM CALIBRATED PRESSURE RANGE**  
0-30 psig .....030  
0-50 psig .....050  
0-100 psig ..... 100  
Consult Master Pneumatic for any other pressure ranges.
- MONITOR SIGNAL**  
0-10 VDC.....A  
4-20 ma - sinking .....B  
4-20 ma - sourcing .....C
- COMMAND INPUT**  
0-10 VDC..... 1  
4-20 ma.....2
- PRESSURE GAUGE**  
No gauge .....A  
200-BDD gauge (0-200 psig) .....B  
Electronic gauge: Consult Master Pneumatic for information.

**NOTE:** Cable must be ordered separately. See choices below.

### MOUNTING BRACKETS

Order mounting brackets separately.

Bracket for servo valve only: Part ER-BRK-1

Brackets for servo valve with volume booster:  
See Regulator Mounting Brackets on page 276.

### CABLES

Cable Length	Part Number
6 feet (1.8 m)	ER-CBL-6
12 feet (3.7 m)	ER-CBL-12
25 feet (7.5 m)	ER-CBL-25

# INTEGRAL FILTER/REGULATORS

The integration of a general purpose filter and a pressure regulator into a single module provides the compactness needed where space is limited. These integral filter/regulators are offered by Master Pneumatic in port sizes from 1/8 up to 3/4 along with models equipped with quick-connect fittings for tubing from 1/4 up to 10 mm.

The regulator is the top portion of the assembly, and the filter is the bottom portion. All sizes have essentially the same operating characteristics as their corresponding individual filters and regulators.

All filter/regulators include an internal automatic filter drain and a pressure gauge as standard equipment. Regulators are self relieving, and have gauge ports front and rear. Non-relieving models are also available.

Available options are the same as those for the corresponding individual filters and regulators. They include regulating springs for various pressure ranges, metal filter bowls, and sintered bronze filter elements in several µm ratings.

## MODULAR or INLINE MOUNTING

**SENTRY**, **GUARDSMAN**, **SERIES 380**, and **Full-Size VANGUARD** integral filter/regulators are of modular design.

Units can be connected to lubricators by special modular connectors which seal the faces between units. They may also be inline mounted with pipe nipples. **MINIATURE** filter/regulators are designed for inline mounting only.

All units are available with either **NPTF** or **BSPP** port threads. SAE threads are also available on **GUARDSMAN**, **SERIES 380**, and Full-Size **VANGUARD** models.

## SENTRY FILTER/REGULATORS

Port sizes 1/8 and 1/4 or fittings for tubing up to 10 mm. Modular units have durable plastic, corrosion-resistant bodies. Units are available with either piston or diaphragm type regulators. A non-relieving version can be used with water, oil, and many other liquids.



## GUIDE to INTEGRAL FILTER/REGULATORS

Filter/Regulator Series	Modular Construction	Port Sizes					Pages
		1/8	1/4	3/8	1/2	3/4	
<b>SENTRY</b>							
CFDR10M, 11M models †	yes	X	X				164-165
<b>MINIATURE</b>							
CFDR55M, 56M models	no	X	X				166-167
<b>GUARDSMAN</b>							
CFDR60 models	yes		X	X	X		168-169
<b>GUARDSMAN II</b>							
BCFDR70 models	yes		X	X	X		170-171
<b>Full-Size VANGUARD</b>							
CFDR100 models	yes		X	X	X	X	172-173
<b>Full-Size SERIES 380</b>							
CFDR380 models	yes			X	X	X	174-175

† Also available with quick-connect fittings for tubing up to 10 mm.

### MINIATURE FILTER/REGULATORS



Port sizes 1/8 and 1/4. Built to the same performance standards as the **SENTRY** units, but are non-modular and at lower cost.

### Full Size VANGUARD FILTER/REGULATORS

Port sizes 1/4 through 3/4. Polycarbonate plastic filter bowl with steel shatterguard standard. Optional zinc bowl with clear nylon sight glass. Regulator is a self-relieving diaphragm type; non-relieving also available. Includes pressure adjustment locking key to prevent tampering.



### GUARDSMAN FILTER/REGULATORS

Port sizes 1/4, 3/8, and 1/2. Standard polycarbonate plastic filter bowl has a zinc die-cast shatterguard. A zinc bowl is optionally available. Regulator is a self-relieving piston type; non-relieving also available.



### GUARDSMAN II FILTER/REGULATORS

Port sizes 1/4, 3/8, and 1/2. Standard aluminum filter bowl with clear nylon sight glass. Extra-capacity bowl optionally available. Regulator is a self-relieving piston type; non-relieving also available.



### SERIES 380 FILTER/REGULATORS

Port sizes 3/8, 1/2, 3/4. Polycarbonate plastic filter bowl with steel shatterguard standard. Optional aluminum bowl with clear nylon sight glass. Regulator is a self-relieving diaphragm type; non-relieving also available. Includes pressure adjustment locking key to prevent tampering.



# SENTRY Modular Integral Filter/Regulators



Model Shown: CFDR10M-2

## SPECIFICATIONS

**Ambient/Media Temperature:**

40° to 125°F (4° to 52°C).

**Body:** Acetal.

**Bowl:** 2-Ounce (60-ml) capacity polycarbonate plastic; optional aluminum bowl.

**Dome and Knob:** Acetal.

**Filter Drain:**

Internal automatic drain; optional manual drain.

**Filter Element:** 5- $\mu$ m-rated polyethylene; optional 5- $\mu$ m, 20- $\mu$ m, or 40- $\mu$ m sintered bronze.

**Fluid Media:** Compressed air.

**Inlet Pressure:**

15 psig (1 bar) minimum with automatic drain.  
150 psig (10 bar) maximum.

**Outlet Pressure:** Adjustable up to 100 psig (7 bar).

**Pressure Gauge:** 0 to 160 psig (10.3 bar); 1/8 NPT gauge ports front and rear.

**Panel Mounting:** 1-3/16 inch (30 mm) hole required.

**Seals:** Nitrile.

# CFDR10M, CFDR11M Models Port Sizes: 1/8, 1/4; Tube Fittings

- ◆ Filter and regulator consolidated in a single assembly.
- ◆ Modular assembly and mounting.
- ◆ Threaded ports or quick-connect fittings for tubing up to 10 mm in diameter.
- ◆ 5- $\mu$ m-rated polyethylene filter element; optional sintered bronze elements.
- ◆ High-strength polycarbonate plastic filter bowl; optional metal bowl.
- ◆ Internal automatic drain; optional manual drain.
- ◆ Piston-type regulator (CFDR10M models) or diaphragm-type (CFDR11M models).
- ◆ Self-relieving regulator; non-relieving optional.
- ◆ Pressure gauge.
- ◆ NPTF port threads; optional BSPP threads.

## FLOW CHARTS

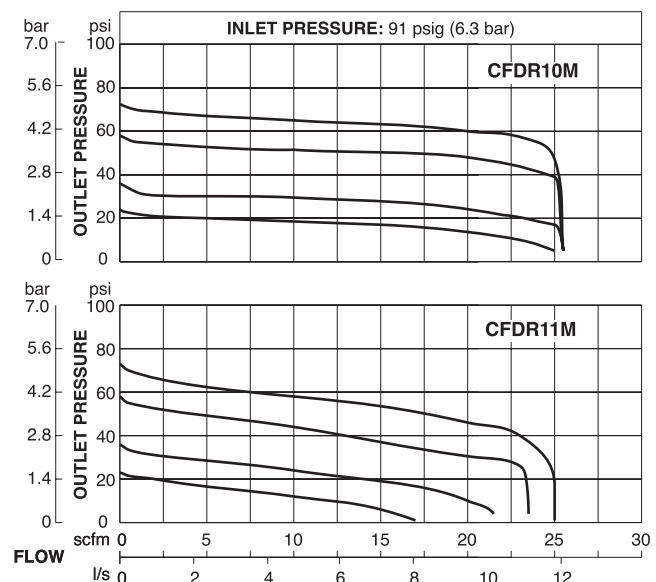

**DIMENSIONS** inches (mm)

Ports	A	B *	C	Depth †	Weight † lb (kg)
No Port	1.7 (43)	3.6 (92)	2.6 (67)	1.8 (45)	0.31 (0.15)
1/8, 1/4	3.0 (76)	3.6 (92)	2.6 (67)	1.8 (45)	0.53 (0.24)

Models below have quick-connect fittings for tubing.

1/4	3.4 (86)	3.6 (92)	2.6 (67)	1.8 (45)	0.51 (0.23)
3/8	3.9 (99)	3.6 (92)	2.6 (67)	1.8 (45)	0.51 (0.23)
4 mm	3.4 (86)	3.6 (92)	2.6 (67)	1.8 (45)	0.51 (0.23)
6 mm	3.4 (86)	3.6 (92)	2.6 (67)	1.8 (45)	0.51 (0.23)
8 mm	3.1 (79)	3.6 (92)	2.6 (67)	1.8 (45)	0.51 (0.23)
10 mm	3.9 (99)	3.6 (92)	2.6 (67)	1.8 (45)	0.51 (0.23)

\* Dimension with plastic filter bowl; with metal bowl is 4.3 (109).

† Less gauge.

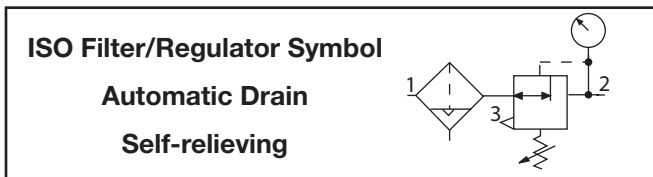
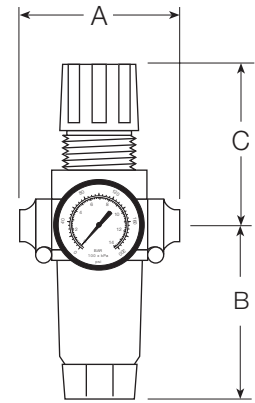

**REPLACEMENT FILTER ELEMENT KITS**

Element Type	Kit Number
5-µm polyethylene (Std element).....	KA130-27PE5
5-µm bronze .....	KA130-27E5
20-µm bronze .....	KA130-27E4
40-µm bronze .....	KA130-27E3

**ORDERING INFORMATION**

Change the letters in the sample model number below to specify the filter/regulator you want.

**B C FD R10M P - 2 X Y G W**

**BOWL TYPE**

Plastic bowl ..... Leave Blank  
Metal bowl..... B

**FILTER DRAIN**

Internal automatic drain ..... FD  
Manual drain..... F

**REGULATOR TYPE**

Piston type ..... R10M  
Diaphragm type..... R11M

**MOUNTING HOLE LOCATION**

Bottom mount (Standard) ..... Leave Blank  
Top mount ..... P

**INLET PORT SIZE**

No Inlet and Outlet Ports ..... Leave blank

**Threaded:**

1/8 NPTF ..... 1  
1/4 NPTF ..... 2

**Fittings for Tubing:**

1/4..... 04  
3/8..... 06  
4 mm..... M4  
6 mm..... M6  
8 mm..... M8  
10 mm..... M10

**OUTLET PORT SIZE**

Same as inlet port ..... Leave Blank

**Threaded:**

1/8 NPTF ..... -1  
1/4 NPTF ..... -2

**Fittings for Tubing:**

1/4..... -04  
3/8..... -06  
4 mm..... -M4  
6 mm..... -M6  
8 mm..... -M8  
10 mm..... -M10

**PORT TYPE**

As specified in **INLET PORT**... Leave Blank  
BSPP threads on both ports..... W

**OPTIONS** (More than one option can be chosen)

0-160 psig Gauge ..... Leave Blank  
No psig Gauge ..... NG  
Plastic nut ..... P  
Metal nut ..... PN  
Hex plastic mounting nut ..... PE

**OPTIONS** (More than one option can be chosen)

None ..... Leave Blank  
Non-relieving ..... A  
Sintered bronze filter element:  
5-µm rating..... E5  
20-µm rating..... E4  
40-µm rating..... E3  
Adjusting springs:  
0-125 psig (0-8.6 bar)..... H  
0-50 psig (0-3.4 bar)..... L  
0-8 psig (0-0.6 bar)..... L8  
0-15 psig (0-1.0 bar)..... L15  
0-30 psig (0-2.1 bar)..... L30  
Tamper-resistant spinning knob (psig preset) ..... MV(\*)  
Viton seals ..... V

\*Insert maximum limited pressure.

**MOUNTING BRACKETS**

See page 276.

**Integral FILTER/REGULATORS**

# MINIATURE Integral Filter/Regulators

# CFDR55M, CFDR56M Models Port Sizes: 1/8, 1/4



Model Shown: CFDR55M-2

- ◆ Filter and regulator consolidated in a single assembly.
- ◆ Inline mounting.
- ◆ 5- $\mu$ m-rated polyethylene filter element; optional sintered bronze elements.
- ◆ High-strength polycarbonate plastic filter bowl; optional aluminum bowl.
- ◆ Internal automatic drain; optional manual drain.
- ◆ Piston-type regulator (CFDR55M models) or diaphragm-type (CFDR56M models).
- ◆ Self-relieving regulator; non-relieving optional.
- ◆ Pressure gauge.
- ◆ NPTF port threads; optional BSPP threads.

## SPECIFICATIONS

### Ambient/Media Temperature:

40° to 125°F (4° to 52°C).

**Body:** Aluminum.

**Bowl:** 2-Ounce (60-ml) capacity polycarbonate plastic; optional aluminum bowl.

**Dome and Knob:** Acetal.

### Filter Drain:

Internal automatic drain; optional manual drain.

**Filter Element:** 5- $\mu$ m-rated polyethylene; optional 5- $\mu$ m, 20- $\mu$ m, or 40- $\mu$ m sintered bronze.

**Fluid Media:** Compressed air.

### Inlet Pressure:

15 psig (1 bar) minimum with automatic drain.

Plastic bowl: 150 psig (10 bar) maximum.

Metal bowl: 200 psig (14 bar) maximum.

**Outlet Pressure:** Adjustable up to 100 psig (7 bar).

**Pressure Gauge:** 0 to 160 psig (10.3 bar); 1/8 NPT gauge ports front and rear.

**Panel Mounting:** 1-3/16 inch (30 mm) hole required.

**Seals:** Nitrile.

## FLOW CHARTS

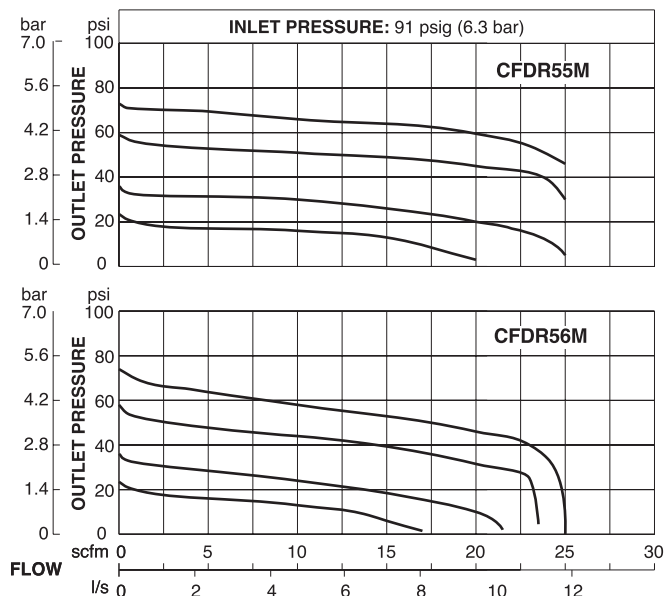

## DIMENSIONS inches (mm)

Bowl	Ports	A	B	C	Depth †	Weight † lb (kg)
Plastic	1/8, 1/4	1.6 (41)	3.6 (92)	2.6 (67)	1.6 (41)	0.53 (0.24)
Metal	1/8, 1/4	1.6 (41)	4.3 (109)	2.6 (67)	1.6 (41)	0.53 (0.24)

† Less gauge.

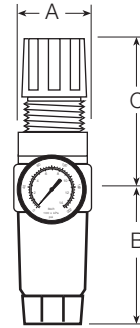

### ISO Filter/Regulator Symbol

**Automatic Drain**  
**Self-relieving**

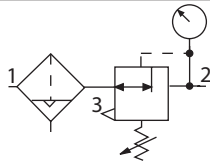

## REPLACEMENT FILTER ELEMENT KITS

Element Type	Kit Number
5-µm polyethylene (Std element).....	KA130-27PE5
5-µm bronze .....	KA130-27E5
20-µm bronze .....	KA130-27E4
40-µm bronze .....	KA130-27E3

## ORDERING INFORMATION

Change the letters in the sample model number below to specify the filter/regulator you want.

**B C FD R55M - 2 Y G W**

### BOWL TYPE

Plastic bowl ..... Leave Blank  
Metal bowl.....B

### FILTER DRAIN

Internal automatic drain ..... FD  
Manual drain..... F

### REGULATOR TYPE

Piston type .....R55M  
Diaphragm type.....R56M

### PORT SIZE

1/8 NPTF..... 1  
1/4 NPTF..... 2

### PORT TYPE

NPTF Threads ..... Leave Blank  
BSPP threads ..... W

### OPTIONS (More than one option can be chosen)

0-160 psig Gauge .....Leave Blank  
No psig Gauge ..... NG  
Plastic nut ..... P  
Metal nut .....PN  
Hex plastic mounting nut ..... PE

### OPTIONS (More than one option can be chosen)

None ..... Leave Blank  
Non-relieving ..... A  
Small valve seat (provides lower flow, greater precision)..... C  
Metal dome (threaded)..... D  
Sintered bronze filter element:  
5-µm rating ..... E5  
20-µm rating ..... E4  
40-µm rating ..... E3  
Adjusting springs:  
0-125 psig (0-8.6 bar) ..... H  
0-50 psig (0-3.4 bar) ..... L  
0-8 psig (0-0.6 bar) ..... L8  
0-15 psig (0-1.0 bar) ..... L15  
0-30 psig (0-2.1 bar) ..... L30

### Tamper-resistant spinning

knob (psig preset)..... MV(\*)  
No gauge ports ..... NP  
Viton seals..... V

\*Insert maximum limited pressure.

### MOUNTING BRACKETS

See page 276.

# GUARDSMAN Modular Integral Filter/Regulators

# CFDR60 Models Port Sizes: 1/4, 3/8, 1/2



Model Shown: CFDR60-3

## SPECIFICATIONS

### Ambient/Media Temperature:

Plastic Bowl: 40° to 125°F (4° to 52°C).  
Metal Bowl: 40° to 175°F (4° to 79°C).

**Body:** Zinc.

**Bowl:** 4-Ounce (120-ml) capacity polycarbonate plastic with zinc shatterguard; optional zinc bowl.

**Dome and Knob:** Acetal.

### Filter Drain:

Internal automatic drain; optional manual drain.

Filter Element: 5- $\mu$ m-rated polyethylene; optional 5- $\mu$ m, 20- $\mu$ m, or 40- $\mu$ m sintered bronze.

**Fluid Media:** Compressed air.

### Inlet Pressure:

15 psig (1 bar) minimum with automatic drain.  
Plastic bowl: 150 psig (10 bar) maximum.  
Metal bowl: 200 psig (14 bar) maximum.

**Outlet Pressure:** Adjustable up to 100 psig (7 bar).

**Pressure Gauge:** 0 to 200 psig (14 bar); 1/4 NPT gauge ports front and rear.

**Panel Mounting:** 1-9/16 inch (40 mm) hole required.

**Seals:** Nitrile

- ◆ Filter and regulator consolidated in a single assembly.
- ◆ Modular or inline mounting.
- ◆ 5- $\mu$ m-rated polyethylene filter element; optional sintered bronze elements.
- ◆ High-strength polycarbonate plastic filter bowl with zinc shatterguard; optional zinc bowl.
- ◆ Internal automatic drain; optional manual drain.
- ◆ Self-relieving piston-type regulator; non-relieving optional.
- ◆ Pressure gauge.
- ◆ NPTF port threads; optional SAE or BSPP threads.

## FLOW CHARTS

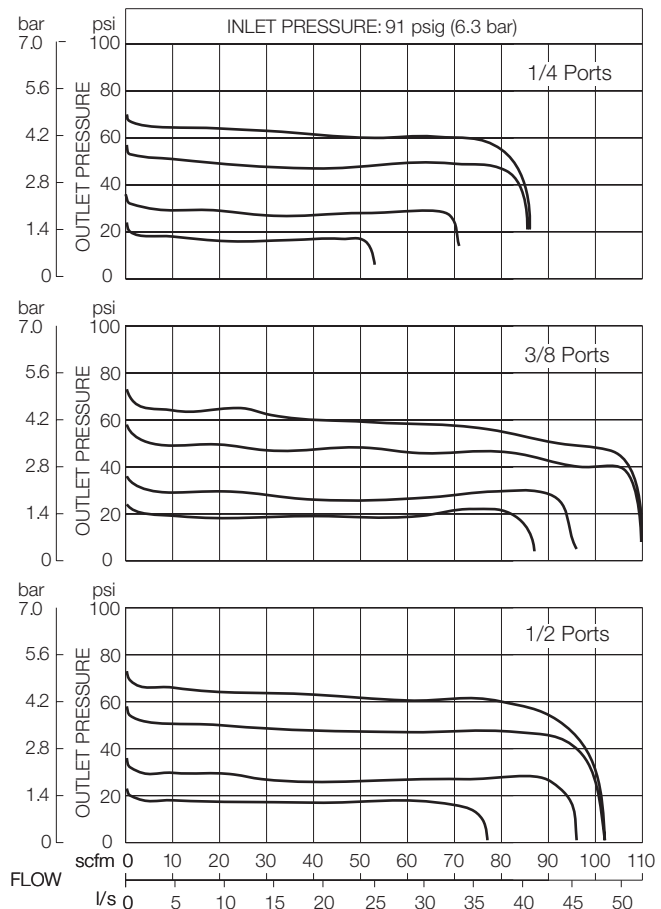



## DIMENSIONS inches (mm)

Bowl	A	B *	C **	Depth †	Weight † lb (kg)
Plastic	2.7 (67)	4.6 (116)	3.3 (83)	2.4 (60)	1.44 (0.65)
Metal	2.7 (67)	4.9 (123)	3.3 (83)	2.4 (60)	1.50 (0.68)

† Less gauge.

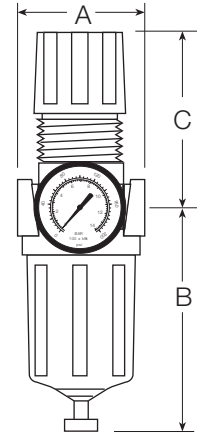

### ISO Filter/Regulator Symbol

**Automatic Drain**  
**Self-relieving**

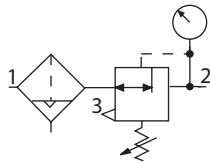

## REPLACEMENT FILTER ELEMENT KITS

Element Type	Kit Number
5- $\mu$ m polyethylene (Std element).....	KA60F-03
5- $\mu$ m bronze .....	KA60F-03E5
20- $\mu$ m bronze .....	KA60F-03E4
40- $\mu$ m bronze .....	KA60F-03E3

## ORDERING INFORMATION

Change the letters in the sample model number below to specify the filter/regulator you want.

**B C FD R60- 2 Y G W**

### BOWL TYPE

Plastic bowl..... Leave Blank  
Metal bowl..... B

### FILTER DRAIN

Internal automatic drain ..... FD  
Manual drain..... F

### PORT SIZE

1/4 NPTF..... 2  
3/8 NPTF..... 3  
1/2 NPTF..... 4  
9/16-18 UNF SAE ..... S6

### PORT TYPE

NPTF Threads ..... Leave Blank  
BSP threads ..... W

### OPTIONS (More than one option can be chosen)

0-200 psig Gauge ..... Leave Blank  
No psig Gauge ..... NG  
Mounting nut ..... P

### OPTIONS (More than one option can be chosen)

None ..... Leave Blank  
Non-relieving ..... A

### Sintered bronze filter element:

5- $\mu$ m rating ..... E5  
20- $\mu$ m rating ..... E4  
40- $\mu$ m rating ..... E3

### Adjusting springs:

0-150 psig (0-10 bar) ..... H  
0-50 psig (0-3.4 bar) ..... L

### MOUNTING BRACKETS

See page 276.

# GUARDSMAN II Modular Integral Filter/Regulators

# BCFDR70 Models Port Sizes: 1/4, 3/8, 1/2



Model Shown: BCFDR70-4

- ◆ Filter and regulator consolidated in a single assembly.
- ◆ Modular or inline mounting.
- ◆ 5- $\mu$ m-rated polyethylene filter element; optional sintered bronze elements.
- ◆ Aluminum bowl with clear nylon sight glass. Bowl can be rotated for easy readability.
- ◆ Internal automatic drain; optional manual drain.
- ◆ Self-relieving piston-type regulator; non-relieving optional.
- ◆ Pressure gauge; two gauge ports.
- ◆ NPTF port threads; optional SAE or BSPP threads.

## SPECIFICATIONS

### Ambient/Media Temperature:

40° to 175°F (4° to 79°C).

**Body:** Zinc.

**Bowl:** 6-Ounce (180-ml) capacity aluminum with clear nylon sight glass. Optional 10-ounce (300-ml) extended bowl.

**Dome and Knob:** Acetal.

### Filter Drain:

Internal automatic drain; optional manual drain.

**Filter Element:** 5- $\mu$ m-rated polyethylene; optional 5- $\mu$ m or 40- $\mu$ m sintered bronze.

**Fluid Media:** Compressed air.

### Inlet Pressure:

15 psig (1 bar) minimum with automatic drain.  
200 psig (14 bar) maximum.

**Outlet Pressure:** Adjustable up to 100 psig (7 bar).

**Pressure Gauge:** 0 to 200 psig (14 bar); 1/4 NPT gauge ports front and rear.

**Panel Mounting:** 1-9/16 inch (40 mm) hole required.

**Seals:** Nitrile.

## FLOW CHARTS

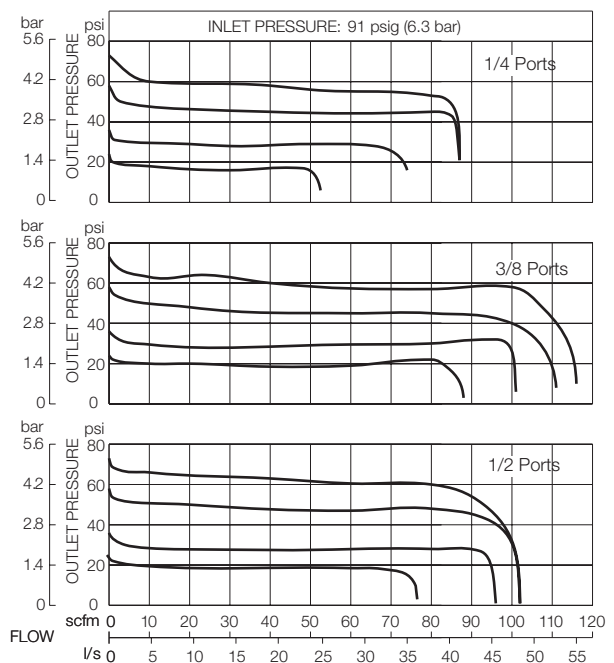

### DIMENSIONS inches (mm)

Bowl	A	B	C	Depth †	Weight † lb (kg)
Standard	2.7 (67)	5.9 (151)	3.3 (83)	2.4 (60)	1.50 (0.68)
Extended	2.7 (67)	8.9 (227)	3.3 (83)	2.4 (60)	1.75 (0.80)

† Less gauge.

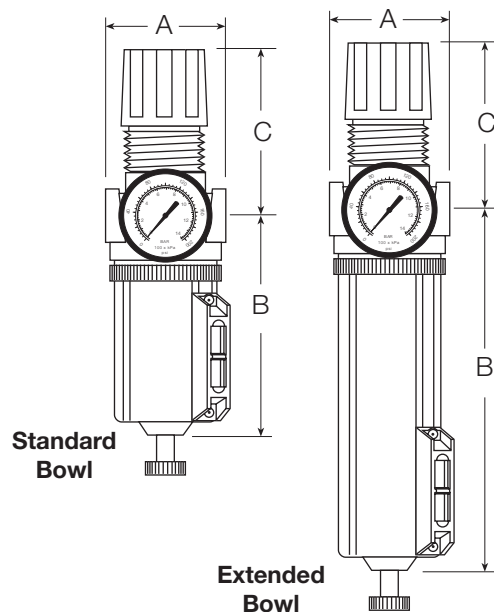

### ISO Filter/Regulator Symbol

Automatic Drain  
Self-relieving

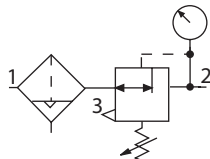

### REPLACEMENT FILTER ELEMENT KITS

Element Type	Kit Number
5- $\mu$ m polyethylene (Std element).....	KA60F-03PE5
5- $\mu$ m bronze .....	KA60F-03E5
40- $\mu$ m bronze .....	KA60F-03E3

### ORDERING INFORMATION

Change the letters in the sample model number below to specify the filter/regulator you want.

**BC FD R 70 - 2 Y G W**

#### FILTER DRAIN

Internal automatic drain ..... FD  
Manual drain..... F

#### BOWL SIZE

Standard 6-ounce bowl..... 70  
Extended 10-ounce bowl ..... 70H

#### PORT SIZE

1/4 NPTF..... 2  
3/8 NPTF..... 3  
1/2 NPTF..... 4  
9/16-18 UNF SAE ..... S6

#### PORT TYPE

NPTF Threads ..... Leave Blank  
BSPB threads ..... W

#### OPTIONS (More than one option can be chosen)

0-200 psig Gauge ..... Leave Blank  
No psig Gauge ..... NG  
Mounting nut ..... P

#### OPTIONS (More than one option can be chosen)

None ..... Leave Blank  
Non-relieving ..... A  
Sintered bronze filter element:  
5- $\mu$ m rating ..... E5  
40- $\mu$ m rating ..... E3  
Adjusting springs:  
0-150 p sig (0-10 bar) ..... H  
0-50 psig (0-3.4 bar) ..... L

### MOUNTING BRACKETS

See page 276.

Integral  
FILTER/REGULATORS

# Full-Size VANGUARD Modular Integral Filter/Regulators

# CFDR100 Models Port Sizes: 1/4, 3/8, 1/2, 3/4



Model Shown: CFDR100-6

- ◆ Filter and regulator consolidated in a single assembly.
- ◆ Modular assembly and mounting.
- ◆ 5- $\mu$ m-rated polyethylene filter element; optional sintered bronze elements.
- ◆ High-strength polycarbonate plastic filter bowl with steel shatterguard; optional metal bowl with clear nylon sight glass.
- ◆ Internal automatic drain; optional manual drain or external Hydro-Jector drain.
- ◆ Self-relieving diaphragm-type regulator; non-relieving optional.
- ◆ Pressure adjustment locking key.
- ◆ Pressure gauge.
- ◆ NPTF port threads; optional SAE or BSPP threads.

## SPECIFICATIONS

### Ambient/Media Temperature:

Plastic Bowl: 40° to 125°F (4° to 52°C).  
Metal Bowl: 40° to 175°F (4° to 79°C).

**Body:** Zinc.

**Bowl:** 8-Ounce (240-ml) capacity polycarbonate plastic with steel shatterguard; optional zinc bowl with clear nylon sight glass.

**Dome:** Nylon. Aluminum with option H spring.

**Filter Drain:** Internal automatic drain; optional manual drain or external Hydro-Jector drain.

**Filter Element:** 5- $\mu$ m-rated polyethylene; optional 5- $\mu$ m, 20- $\mu$ m, or 40- $\mu$ m sintered bronze.

**Fluid Media:** Compressed air.

### Inlet Pressure:

15 psig (1 bar) minimum with automatic drain.  
Plastic bowl: 150 psig (10 bar) maximum.  
Metal bowl: 200 psig (14 bar) maximum.

**Knob:** Acetal.

**Outlet Pressure:** Adjustable up to 125 psig (8.6 bar).

**Pressure Adjustment Locking Key:** Removable.

**Pressure Gauge:** 0 to 200 psig (14 bar); 1/4 NPT gauge ports front and rear.

**Panel Mounting:** 2-1/16 inch (52 mm) hole required.

**Seals:** Nitrile

## FLOW CHARTS

Standard 5- $\mu$ m Element

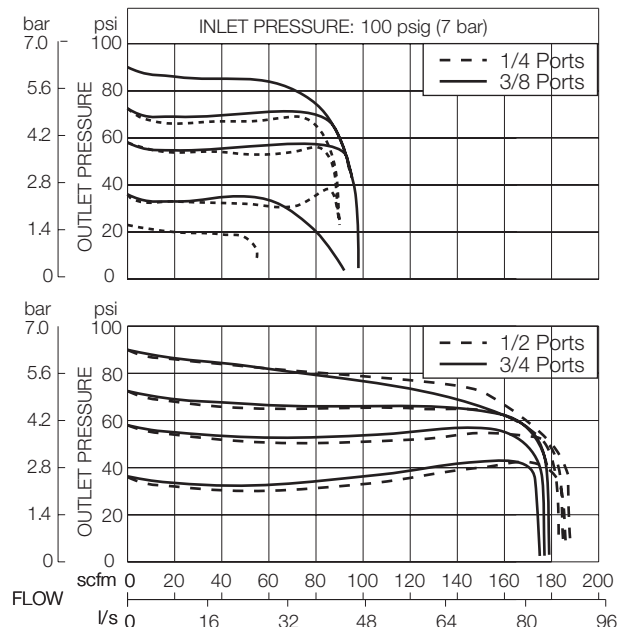

## DIMENSIONS inches (mm)

Bowl	A	B *	C **	Depth †	Weight † lb (kg)
Plastic	3.5 (89)	5.8 (146)	5.8 (146)	3.5 (89)	2.50 (1.15)
Metal	3.5 (89)	6.4 (163)	5.8 (146)	3.5 (89)	2.55 (1.17)

\* Bowl removal clearance: add 3.1 (79).

\*\* Dome removal clearance: add 0.63 (16).

† Less gauge.

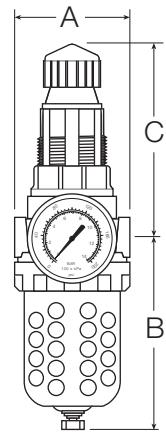

### ISO Filter/Regulator Symbol

**Automatic Drain**  
**Self-relieving**

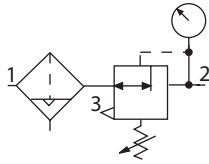

## REPLACEMENT FILTER ELEMENT KITS

Element Type	Kit Number
5-µm polyethylene (Std element).....	KA103-3PE
5-µm bronze .....	KA103-03 E5
20-µm bronze .....	KA103-03E4
40-µm bronze .....	KA103-03E3

## ORDERING INFORMATION

Change the letters in the sample model number below to specify the filter/regulator you want.

**B C FD R100-2 Y G W**

### BOWL TYPE

Plastic bowl ..... Leave Blank  
Metal bowl ..... B

### FILTER DRAIN

Internal automatic drain ..... FD  
Manual drain ..... F  
External Hydro-Jector drain ..... FE

### PORT SIZE

1/4 NPTF ..... 2  
3/8 NPTF ..... 3  
1/2 NPTF ..... 4  
3/4 NPTF ..... 6  
9/16-18 UNF SAE ..... S6  
3/4-16 UNF SAE ..... S8  
7/8-14 UNF SAE ..... S10

### PORT TYPE

NPTF Threads ..... Leave Blank  
BSPF threads ..... W

### OPTIONS (More than one option can be chosen)

0-200 psig Gauge ..... Leave Blank  
No psig Gauge ..... NG  
Mounting nut ..... P

### OPTIONS (More than one option can be chosen)

None ..... Leave Blank  
Non-relieving ..... A  
Sintered bronze filter element:  
5-µm rating ..... E5  
20-µm rating ..... E4  
40-µm rating ..... E3

### Adjusting springs:

0-20 psig (0-1.4 bar) ..... L20  
0-175 psig (0-12 bar) ..... H\*\*  
0-50 psig (0-3.4 bar) ..... L

Remove adjusting key ..... JJ  
Metal Dome ..... MD  
Limit maximum psig setting .... M\*  
Tee handle ..... T

\* Insert maximum limited pressure.

\*\* H option spring includes metal dome.

### MOUNTING BRACKETS

See page 276.

# Full-Size SERIES 380 Modular Integral Filter/Regulators

# CFDR380 Models Port Sizes: 3/8, 1/2, 3/4



Model Shown: CFDR380-G

- ◆ Filter (FD380) and regulator (R380) consolidated into a single space-saving assembly.
- ◆ Modular or inline mounting.
- ◆ 5- $\mu$ m-rated polyethylene filter element; optional 40- $\mu$ m element.
- ◆ Polycarbonate plastic bowl with steel shatter-guard; optional metal bowl with sight glass.
- ◆ Internal automatic drain; optional manual drain and other drain types.
- ◆ Self-relieving diaphragm-type regulator; non-relieving optional.
- ◆ Pressure adjustment locking key; tamper-resistant pressure setting.
- ◆ Pressure gauge included; two gauge ports.
- ◆ NPTF port threads; optional SAE or BSPP threads.

## SPECIFICATIONS

### Ambient/Media Temperature:

Plastic bowl: 40° to 125°F (4° to 52°C).  
Metal bowl: 40° to 175°F (4° to 79°C).

**Body:** Zinc.

### Bonnet:

**Nylon:** aluminum with optional 0-175 psig spring.

**Bowl:** 9-Ounce (270-ml) polycarbonate plastic with steel shatterguard; optional aluminum bowl with clear nylon sight glass.

**Bowl Drain:** Internal automatic drain; optional manual drain and other drain types.

**Cap Color:** Black.

**Filter Element:** 5- $\mu$ m-rated polyethylene; optional 40- $\mu$ m element.

**Fluid Media:** Compressed air.

### Inlet Pressure:

15 psig (1 bar) minimum with automatic drain.  
Plastic bowl: 150 psig (10 bar).  
Metal bowl: 200 psig (14 bar).

**Outlet Pressure:** Adjustable up to 125 psig (8.6 bar); optional adjusting springs.

**Pressure Adjustment Locking Key:** Removable.

**Pressure Gauge:** 0 to 200 psig (14 bar); 1/4 NPT gauge ports front and rear.

**Panel Mounting:** 2.05-inch (52.1-mm) hole required.

**Seals:** Nitrile.

**Valve:** Brass.

## FLOW CHARTS

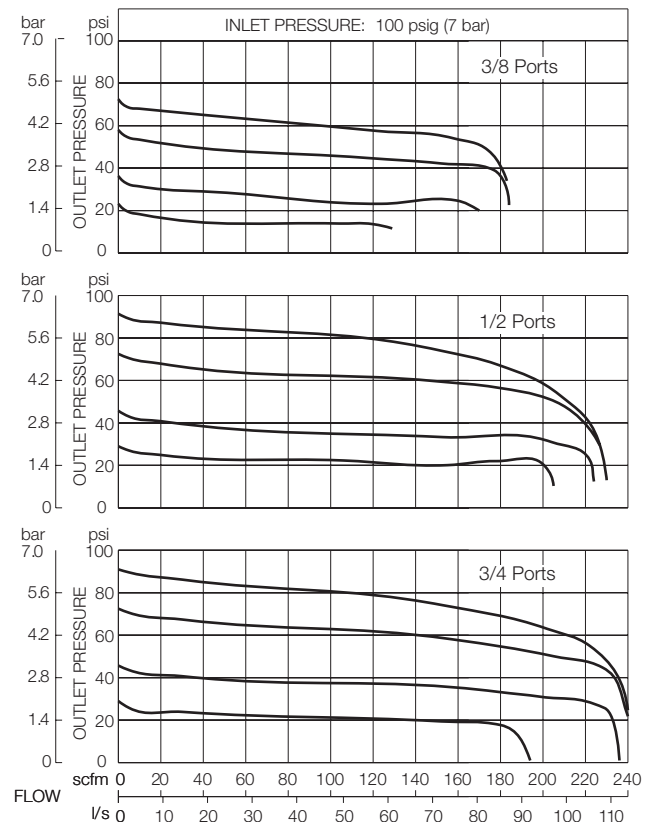

## DIMENSIONS inches (mm)

Bowl	A	B *	C **	Depth †	Weight † lb (kg)
Polycarbonate	3.5 (88)	7.7 (195)	5.4 (137)	2.9 (73)	3.69 (1.68)
Metal	3.5 (88)	7.6 (193)	5.4 (137)	2.9 (73)	3.69 (1.68)

\* Bowl removal clearance: add 3.1 (79).

\*\* Dome removal clearance: add 0.63 (16).

† Less gauge.

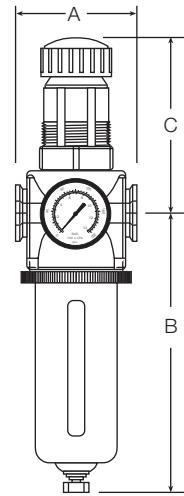

### ISO Filter/Regulator Symbol

Automatic Drain

Self-relieving

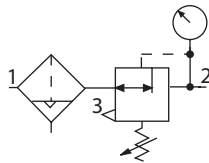

## REPLACEMENT FILTER ELEMENT KITS

Element Rating	Kit Number
5-µm Polyethylene (Std element)	A115-106PE5
40-µm Polyethylene	A115-106PE3
5-µm Bronze	A115-106E5
20-µm Bronze	A115-106E4

## ORDERING INFORMATION

Change the letters in the sample model number below to specify the filter/regulator you want.

**B** **CFD** **R** **380-3** **Y** **G** **W**

**BOWL TYPE**  
 Plastic with guard ..... Leave Blank  
 Metal with sight glass ..... B

**BOWL DRAIN**  
 Internal automatic drain ..... CFD  
 Manual drain..... CF

**PORT SIZE**  
 3/8 NPTF..... 3  
 1/2 NPTF..... 4  
 3/4 NPTF..... 6  
 3/4-16 UNF SAE ..... S8  
 7/8-14 UNF SAE ..... S10

### PORT TYPE

NPTF Threads ..... Leave Blank  
 BSPP threads ..... W

### OPTIONS (More than one option can be chosen)

None ..... Leave Blank  
 Panel mounting nut ..... P  
 0-200 psig Gauge ..... G

### OPTIONS (More than one option can be chosen)

None ..... Leave Blank  
 Non-relieving ..... A  
 40-µm rated filter element..... E3  
 Sintered bronze filter element  
     5-µm rating ..... E5  
     20-µm rating..... E4  
     0-175 psig (0-12 bar) ..... H\*\*  
 Remove adjusting key ..... JJ  
 Adjusting spring  
     0-50 psig (0-3.4 bar) ..... L  
 Metal Dome ..... MD  
 Limit maximum psig setting .... M\*  
 Tee handle..... T

\* Insert maximum limited pressure.

\*\* H option spring includes metal dome

### MOUNTING BRACKETS

See page 276.

# AIR LINE LUBRICATORS

## LUBRICATOR FUNCTION

Air line lubricators are designed to introduce atomized oil into the air line so that downstream mechanisms can be adequately lubricated. Lubricators should be adjusted so that the minimum amount of oil to lubricate the equipment is used. Excess oil will simply be blown into the atmosphere and pollute the environment.

There are two basic designs used in Master Pneumatic lubricators: sight-feed design and wick-feed design. Illustrations of these two types of assembly are shown on the facing page.

## SIGHT-FEED LUBRICATORS

Air flows through a flexible-vane automatic flow sensor that creates a small pressure differential between the air passage and the oil reservoir. This differential causes oil to move up a riser tube, through an adjustable metering valve, and then to drip into a transparent dome and the air stream. This oil is “atomized” by the air stream, and carried down the air line to the points of lubrication.

Sight-feed lubricators are easy to adjust, and an indicator on the sight dome measures the amount of oil dispensed. The adjusting knob can be removed to make the lubricator “tamper-resistant.”

All working parts are in an easily replaceable cartridge.

Note: Not recommended for valve and cylinder circuits (see **INJECTION LUBRICATORS** section).

## WICK-FEED LUBRICATORS

In a wick-feed lubricator one end of a porous bronze wick is saturated with oil in the reservoir. Capillary action causes the oil to travel up the wick. Oil is stripped off the upper portion of the wick by the air flow, and maintains a constant oil-to-air ratio. This ratio can be varied by manual adjustment. Units will not shut off, even with dirt and moisture in the reservoir. However, air must be shut off when filling the reservoirs of these models.

## MODULAR or INLINE MOUNTING

**SENTRY, GUARDSMAN, SERIES 380, and Full-Size VANGUARD** lubricators are of modular design. They are connected to other units by special modular connectors which seal the faces between units. They may also be inline mounted with pipe nipples.

**MINIATURE and High-Capacity VANGUARD** lubricators are inline mounted only.

## GUIDE to AIR LINE LUBRICATORS

For precision controlled lubrication see **INJECTION LUBRICATORS** section.

Regulator Series	Modular Construction	Port Sizes								Pages	
		1/8	1/4	3/8	1/2	3/4	1	1-1/4	1-1/2		2
<b>SENTRY †</b>											
Wick-Feed L10 models	yes	X	X								178-179
<b>MINIATURE</b>											
Wick-Feed L50, L50Y models	no	X	X								180-181
<b>GUARDSMAN</b>											
Sight-Feed L60D models	yes		X	X	X						182-183
<b>GUARDSMAN II</b>											
Sight-Feed BL70D models	yes		X	X	X						184-185
<b>Full-Size VANGUARD</b>											
Sight-Feed L28D models	yes		X	X	X	X					186-187
Wick-Feed L28W models	yes		X	X	X	X					188-189
<b>Full-Size SERIES 380</b>											
Sight-Feed L380D models	yes			X	X	X					190-191
<b>High-Capacity VANGUARD</b>											
Sight-Feed L29D models	no					X	X	X	X		192-193
Wick-Feed L100 models	no					X	X				194-195
Sight-Feed BL237 models	no					X	X	X	X		196-197

† Also available with quick-connect tube fittings up to 10 mm.



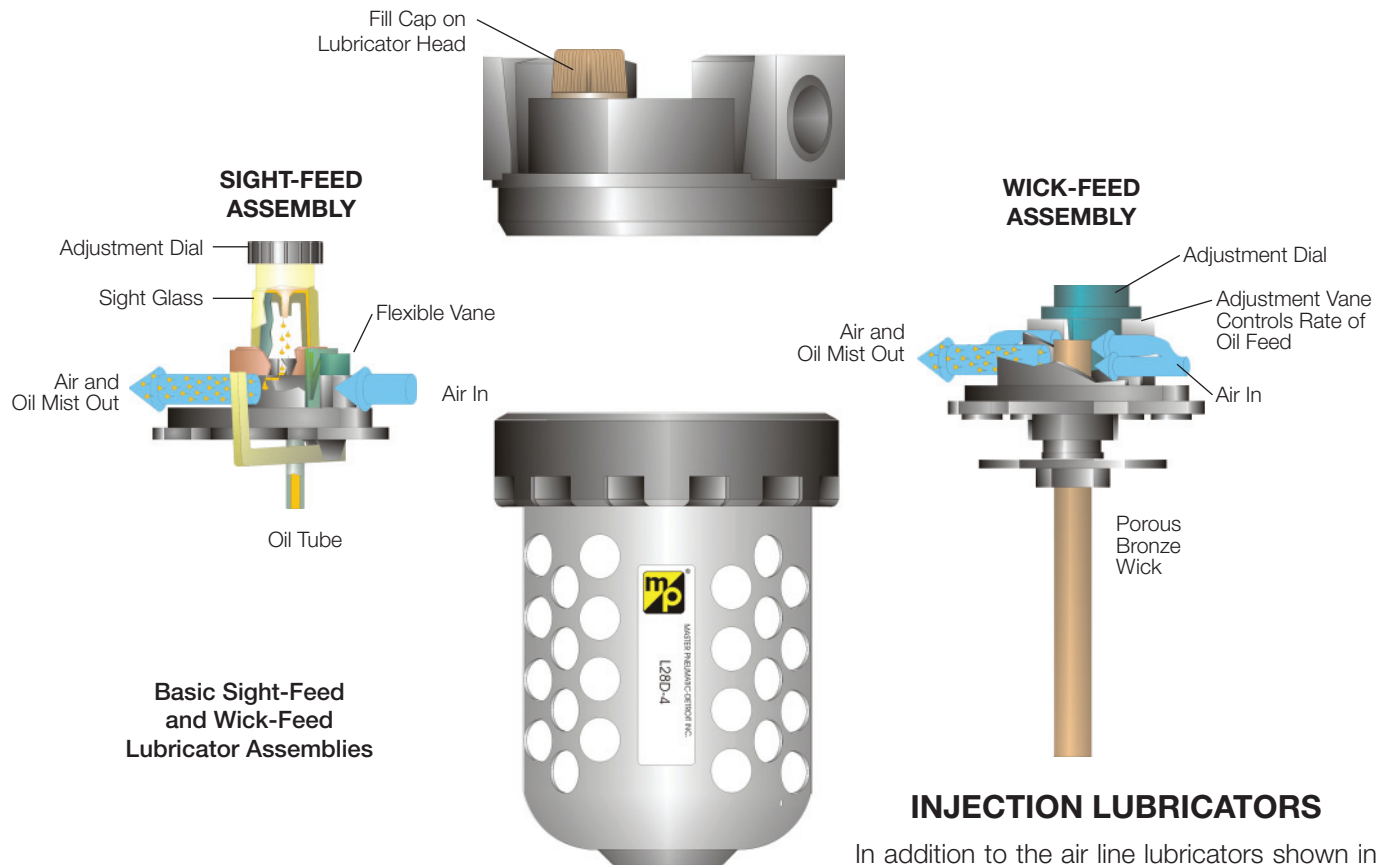

## INJECTION LUBRICATORS

In addition to the air line lubricators shown in this section, see the next section, **INJECTION LUBRICATORS**, for more specialized lubrication units.

## SENTRY LUBRICATORS

Port sizes 1/8 and 1/4 or fittings for tubing up to 10 mm. Wick-feed design and modular assembly. Made of durable, corrosion-resistant acetal. Polycarbonate or aluminum bowl. Air flow to 25 scfm (12 l/s). 2-Ounce (60-ml) bowl capacity.

## MINIATURE LUBRICATORS

Port sizes 1/8 and 1/4. Wick-feed design and inline mounting only. Aluminum head with polycarbonate or aluminum bowl. Air flow to 25 scfm (12 l/s). 2-Ounce (60-ml) bowl capacity. Special low-flow models are designed to deliver oil in situations where air flow is less than 1 scfm.

## GUARDSMAN LUBRICATORS

Series L60D with port sizes 1/4, 3/8, 1/2. Sight-feed design and modular or inline mounting. Polycarbonate bowl with zinc die-cast shatterguard or zinc bowl. Air flow to 110 scfm (52 l/s). 4-Ounce (120-ml) bowl capacity.

## GUARDSMAN II LUBRICATORS

Series BL70D with port sizes 1/4, 3/8, 1/2. Sight-feed design and modular or inline mounting. Zinc head. Aluminum bowl with clear nylon sight glass. Air flow to

110 scfm (52 l/s). 6-Ounce (180-ml) and 10-ounce (300-ml) bowl capacities.

## SERIES 380 LUBRICATORS

Port sizes 3/8, 1/2, 3/4. Sight-feed design and modular or inline mounting. Zinc head. Aluminum bowl with clear nylon sight glass. Air flow to 170 scfm (80 l/s). 9-Ounce (270-ml) and 15-ounce (450-ml) bowls.

## FULL-SIZE VANGUARD LUBRICATORS

Port sizes 1/4, 3/8, 1/2. Either wick-feed or sight-feed design; modular or inline mounting. Air flows up to 140 scfm (66 l/s). Zinc head. Polycarbonate bowl with steel shatterguard or zinc bowl. 8-Ounce (240-ml) or 20-ounce (600-ml) zinc bowls available.

## HIGH-CAPACITY VANGUARD LUBRICATORS

Port sizes 3/4 to 1-1/2. Either wick-feed or sight-feed design; inline mounting only. Air flows up to 500 scfm (235 l/s). Aluminum head. Polycarbonate bowl with steel shatterguard or aluminum bowl. 16-Ounce (480-ml), 35-ounce (1030-ml), or 62-ounce (1830-ml) bowls.

# SENTRY Modular Lubricators

# L10 Models Port Sizes: 1/8, 1/4; Tube Fittings



Model Shown: L10-2

- ◆ Modular assembly and mounting.
- ◆ Threaded ports or quick-connect fittings for tubing up to 10 mm in diameter.
- ◆ Wick-feed design.
- ◆ NPTF port threads; optional BSPP threads.

## SPECIFICATIONS

### Ambient/Media Temperature:

40° to 125°F (4° to 52°C).

**Body:** Acetal.

**Bowl:** 2-Ounce (60-ml) capacity polycarbonate plastic; optional aluminum bowl.

**Fluid Media:** Compressed air.

**Inlet Pressure:** 150 psig (10 bar) maximum.

**Oil Adjustment:** External, no shutoff.

**Seals:** Nitrile.

## FLOW CHART

Inlet Pressure: 100 psig (7 bar)

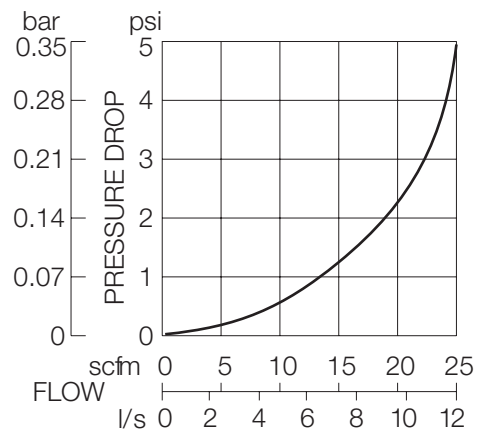

Minimum Flow: 1 scfm (0.47 l/s)

## DIMENSIONS inches (mm)

Ports	A	B †	C	Depth	Weight lb (kg)
No Port	1.7 (43)	3.6 (91)	0.9 (22)	1.8 (45)	0.17 (0.08)
1/8, 1/4	3.0 (76)	3.6 (91)	0.9 (22)	1.8 (45)	0.37 (0.17)
Models below have quick-connect fittings for tubing.					
1/4	3.4 (86)	3.6 (91)	0.9 (22)	1.8 (45)	0.37 (0.17)
3/8	3.9 (99)	3.6 (91)	0.9 (22)	1.8 (45)	0.37 (0.17)
4 mm	3.4 (86)	3.6 (91)	0.9 (22)	1.8 (45)	0.37 (0.17)
6 mm	3.4 (86)	3.6 (91)	0.9 (22)	1.8 (45)	0.37 (0.17)
8 mm	3.1 (79)	3.6 (91)	0.9 (22)	1.8 (45)	0.37 (0.17)
10 mm	3.9 (99)	3.6 (91)	0.9 (22)	1.8 (45)	0.37 (0.17)

† Dimension is for plastic bowl; metal bowl is 3.8 (97).

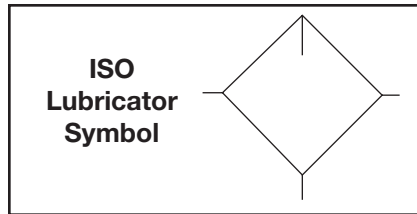
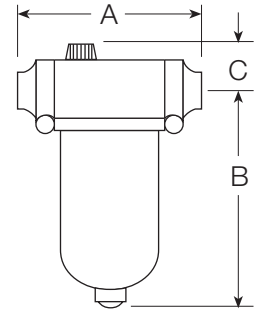

## ORDERING INFORMATION

Change the letters in the sample model number below to specify the lubricator you want.

L10 P - 2 X Y W

**BOWL TYPE**

Plastic ..... L10  
Metal..... BL10

**MOUNTING HOLE LOCATION**

Bottom mount (Standard) ..... Leave Blank  
Top mount ..... P

**INLET PORT SIZE**

No Inlet and Outlet Ports. .. Leave blank

**Threaded:**

1/8 NPTF ..... 1  
1/4 NPTF ..... 2

**Fittings for Tubing:**

1/4 ..... 04  
3/8 ..... 06  
4 mm ..... M4  
6 mm ..... M6  
8 mm ..... M8  
10 mm ..... M10

**PORT TYPE**

As specified in **INLET PORT**... Leave Blank  
BSP threads on both ports..... W

**OPTIONS**

None ..... Leave Blank  
Quick-fill Q-cap..... Q

**OUTLET PORT SIZE**

Same as inlet port ..... Leave Blank

**Threaded:**

1/8 NPTF ..... 1  
1/4 NPTF ..... 2

**Fittings for Tubing:**

1/4 ..... 04  
3/8 ..... 06  
4 mm ..... M4  
6 mm ..... M6  
8 mm ..... M8  
10 mm ..... M10

Air Line  
LUBRICATORS

# MINIATURE Lubricators

## L50, L50-Y Models Port Sizes: 1/8, 1/4



Model Shown: L50-2

- ◆ Inline mounting.
- ◆ High-strength polycarbonate plastic bowl; optional aluminum bowl.
- ◆ Low-flow models (L50Y) are designed to deliver oil in extremely low-flow (less than 1 scfm) situations.
- ◆ Wick-feed design in both standard-flow and low-flow lubricators.
- ◆ Internal tamper-proof adjustment.
- ◆ NPTF port threads; optional BSPP threads.

### SPECIFICATIONS

**Ambient/Media Temperature:**

Plastic bowl: 40° to 125°F (4° to 52°C).  
Metal bowl: 40° to 150°F (4° to 66°C).

**Body:** Aluminum.

**Bowl:** 2-Ounce (60-ml) capacity polycarbonate plastic; optional aluminum bowl.

**Fluid Media:** Compressed air.

**Inlet Pressure:**

Plastic bowl: 150 psig (10 bar) maximum.  
Metal bowl: 200 psig (14 bar) maximum.

**Oil Adjustment:** Internal, tamper-proof.

**Seals:** Nitrile.

### FLOW CHARTS

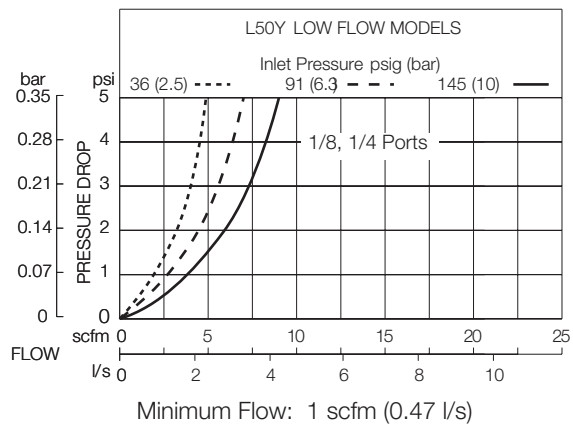
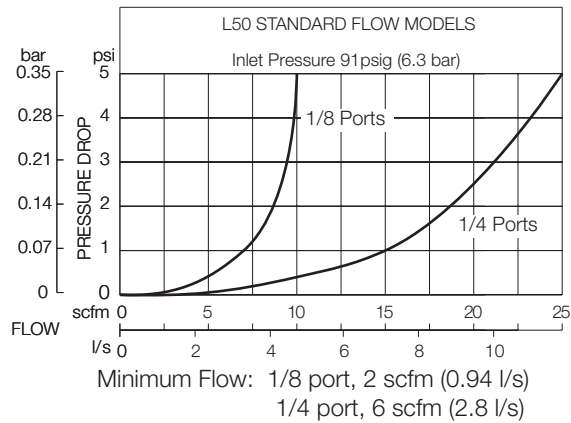

**DIMENSIONS** inches (mm)

Bowl	A	B	C	Depth	Weight lb (kg)
Plastic	1.6 (41)	3.6 (91)	0.7 (17)	1.6 (41)	0.21 (0.10)
Metal	1.6 (41)	3.8 (97)	0.7 (17)	1.6 (41)	0.21 (0.10)

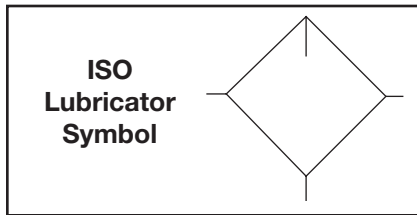
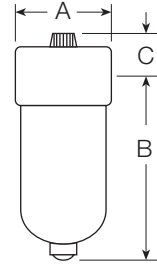

**ORDERING INFORMATION**

Change the letters in the sample model number below to specify the lubricator you want.

**L50 - 2 X W**

<p><b>BOWL TYPE</b></p> <p>Plastic (standard flow)..... L50          Plastic (low flow) .....L50-Y          Metal (standard flow) ..... BL50          Metal (low flow)..... BL50-Y</p> <p><b>PORT SIZE</b></p> <p>1/8 NPTF..... 1          1/4 NPTF..... 2</p>	<p><b>PORT TYPE</b></p> <p>NPTF Threads ..... Leave Blank          BSPP threads ..... W</p> <p><b>OPTIONS:</b> <i>(More than one option can be chosen)</i></p> <p>None ..... Leave Blank          Quick-fill Q-cap..... Q          Tapped modified head to ..... T          to allow 50-01 bracket assy.</p>
--	--

# GUARDSMAN Modular Lubricators

# L60D Models Port Sizes: 1/4, 3/8, 1/2



Model Shown: L60D-2

- ◆ Modular or inline mounting.
- ◆ High-strength polycarbonate plastic bowl with zinc shatterguard. Optional zinc bowl.
- ◆ Sight-feed design.
- ◆ External tamper-resistant adjustment.
- ◆ NPTF port threads; optional SAE or BSPP threads.

## SPECIFICATIONS

### Ambient/Media Temperature:

Plastic bowl: 40° to 125°F (4° to 52°C).

Metal bowl: 40° to 175°F (4° to 79°C).

**Body:** Zinc.

**Bowl:** 4-Ounce (120-ml) polycarbonate plastic with zinc shatterguard; optional zinc bowl.

**Fluid Media:** Compressed air.

### Inlet Pressure:

Plastic bowl: 150 psig (10 bar) maximum.

Metal bowl: 200 psig (14 bar) maximum.

**Oil Adjustment:** External, tamper-resistant.

**Sight Dome:** Nylon.

**Seals:** Nitrile.

## FLOW CHART

Inlet Pressure: 100 psig (7 bar)

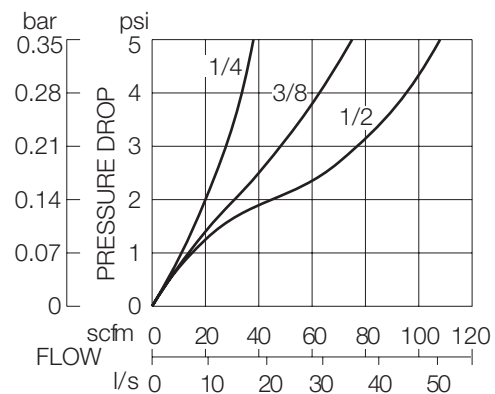

Minimum Flow: 2 scfm (0.94 l/s)

**DIMENSIONS** inches (mm)

Bowl	A	B	C	Depth	Weight lb (kg)
Plastic	2.7 (67)	4.1 (103)	1.8 (46)	2.4 (60)	1.06 (0.48)
Metal	2.7 (67)	4.1 (103)	1.8 (46)	2.4 (60)	1.50 (0.68)

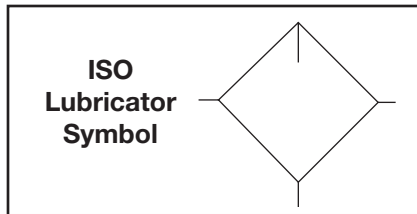
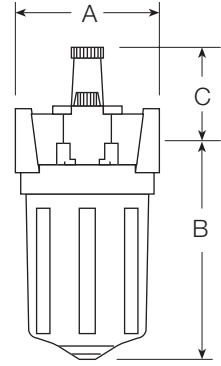

**ORDERING INFORMATION**

Change the letters in the sample model number below to specify the lubricator you want.

**L60D - 2 Y W**

<p><b>BOWL TYPE</b></p> <p>Plastic ..... L60D</p> <p>Metal..... BL60D</p>	<p><b>PORT SIZE</b></p> <p>1/4 NPTF..... 2</p> <p>3/8 NPTF..... 3</p> <p>1/2 NPTF..... 4</p> <p>9/16-18 UNF SAE ..... S6</p>	<p><b>PORT TYPE</b></p> <p>NPTF Threads ..... Leave Blank</p> <p>BSPP threads ..... W</p>	<p><b>OPTIONS</b></p> <p>None ..... Leave Blank</p> <p>Quick-fill Q-cap..... Q</p>
---	--	---	--

# GUARDSMAN II Modular Lubricators

# BL70D Models Port Sizes: 1/4, 3/8, 1/2



Model Shown: BL70D-2

- ◆ Modular or inline mounting.
- ◆ Aluminum bowl with clear nylon sight glass. Bowl can be rotated for easy readability. Optional extended bowl.
- ◆ Sight-feed design.
- ◆ External adjusting knob; removable for tamper resistance.
- ◆ NPTF port threads; optional SAE or BSPP threads.

## SPECIFICATIONS

### Ambient/Media Temperature:

40° to 175°F (4° to 79°C).

**Body:** Zinc.

### Bowl:

6-Ounce (180-ml) capacity aluminum bowl with clear nylon sight glass. Bowl can be rotated for easy readability. Optional 10-ounce (300-ml) extended aluminum bowl.

**Bowl Ring:** Nylon:

**Fluid Media:** Compressed air.

### Inlet Pressure:

200 psig (14 bar) maximum.

**Oil Adjustment:** External, tamper-resistant.

**Seals:** Nitrile.

**Sight Dome:** Nylon.

## FLOW CHART

Inlet Pressure: 100 psig (7 bar)

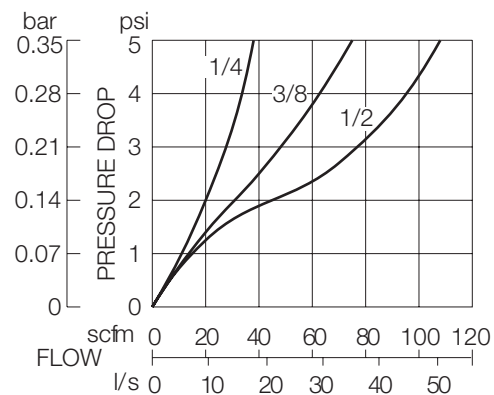

Minimum Flow: 2 scfm (0.94 l/s)



**DIMENSIONS** inches (mm)

Bowl	A	B	C	Depth	Weight lb (kg)
Standard	2.7 (67)	5.9 (151)	1.8 (46)	2.4 (60)	1.25 (0.57)
Extended	2.7 (67)	8.9 (227)	1.8 (46)	2.4 (60)	1.50 (0.68)

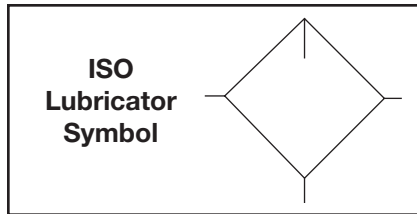
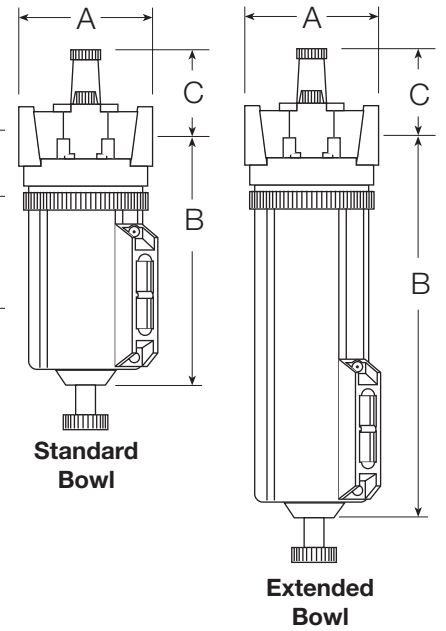

**ORDERING INFORMATION**

Change the letters in the sample model number below to specify the lubricator you want.

**BL 70D - 2 Y W**

**BOWL SIZE**

- Standard 6-ounce bowl ..... 70D
- Extended 10-ounce bowl ..... 70DH

**PORT SIZE**

- 1/4 NPTF ..... 2
- 3/8 NPTF ..... 3
- 1/2 NPTF ..... 4
- 9/16-18 UNF SAE ..... S6

**PORT TYPE**

- NPTF Threads ..... Leave Blank
- BSPP threads ..... W

**OPTIONS**

- None ..... Leave Blank
- Quick-fill Q-cap ..... Q

# Full-Size VANGUARD Modular Lubricators

# L28D Models Port Sizes: 1/4, 3/8, 1/2, 3/4



Model Shown: L28D-3

- ◆ Modular or inline mounting.
- ◆ High-strength polycarbonate plastic bowl with steel shatterguard. Optional zinc bowl with sight glass.
- ◆ Sight-feed design.
- ◆ Optional 20-ounce extended bowl.
- ◆ External adjusting knob; removable for tamper resistance.
- ◆ NPTF port threads; optional SAE or BSPP threads.

## SPECIFICATIONS

### Ambient/Media Temperature:

Plastic bowl: 40° to 125°F (4° to 52°C).

Metal bowl: 40° to 175°F (4° to 79°C).

**Body:** Zinc.

**Bowl:** 8-Ounce (240-ml) capacity polycarbonate plastic with steel shatterguard; optional zinc bowl with sight glass. Optional 20-ounce (600-ml) extended polycarbonate or zinc bowl.

**Bowl Ring:** Aluminum.

**Fluid Media:** Compressed air.

### Inlet Pressure:

Plastic bowl: 150 psig (10 bar) maximum.

Metal bowl: 200 psig (14 bar) maximum.

**Oil Adjustment:** External, tamper-resistant.

**Seals:** Nitrile.

**Sight Dome:** Nylon.

## FLOW CHART

Inlet Pressure: 100 psig (7 bar)

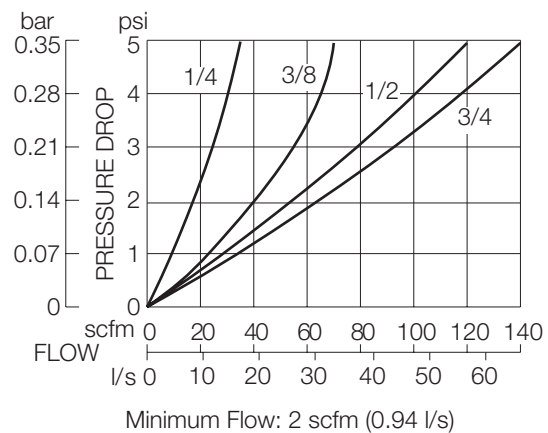

**DIMENSIONS** inches (mm)

Bowl	A	B	C	Depth	Weight lb (kg)
Standard Plastic	3.5 (89)	5.2 (132)	1.3 (32)	3.5 (89)	2.06 (0.94)
Extended Plastic	3.5 (89)	9.7 (246)	1.3 (32)	3.5 (89)	3.75 (1.70)
Standard Metal	3.5 (89)	5.3 (135)	1.3 (32)	3.5 (89)	2.90 (1.32)
Extended Metal	3.5 (89)	9.8 (249)	1.3 (32)	3.5 (89)	4.65 (2.11)

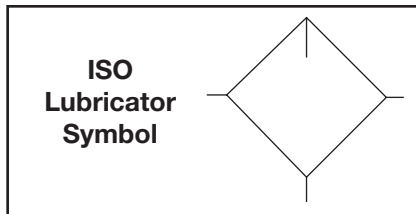
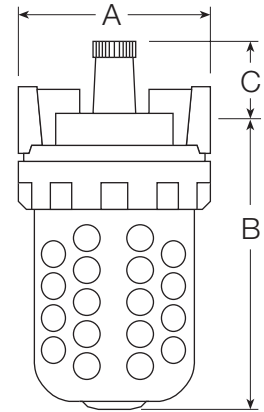

**ORDERING INFORMATION**

Change the letters in the sample model number below to specify the lubricator you want.

**L28D - 2 Y W**

**BOWL TYPE**

- 8-Ounce plastic ..... L28D
- 8-Ounce metal ..... BL28D
- 20-Ounce plastic ..... L28DH
- 20-Ounce metal ..... BL28DH

**PORT SIZE**

- 1/4 NPTF ..... 2
- 3/8 NPTF ..... 3
- 1/2 NPTF ..... 4
- 3/4 NPTF ..... 6
- 9/16-18 UNF SAE ..... S6
- 3/4-16 UNF SAE ..... S8
- 7/8-14 UNF SAE ..... S10

**PORT TYPE**

- NPTF Threads ..... Leave Blank
- BSPP threads ..... W

**OPTIONS**

- None ..... Leave Blank
- Quick-fill Q-cap ..... Q

# Full-Size VANGUARD Modular Lubricators

# L28W Models Port Sizes: 1/4, 3/8, 1/2, 3/4



Model Shown: L28W-4

- ◆ Modular or inline mounting.
- ◆ High-strength polycarbonate plastic bowl with steel shatterguard. Optional zinc bowl.
- ◆ Wick-feed design.
- ◆ External adjusting knob.
- ◆ NPTF port threads; optional SAE or BSPP threads.

## SPECIFICATIONS

### Ambient/Media Temperature:

Plastic bowl: 40° to 125°F (4° to 52°C).  
Metal bowl: 40° to 175°F (4° to 79°C).

**Adjusting Knob:** Acetal.

**Body:** Zinc.

**Bowl:** 8-Ounce (240-ml) capacity polycarbonate plastic with steel shatterguard. Optional zinc bowl.

**Bowl Ring:** Aluminum.

**Fluid Media:** Compressed air.

### Inlet Pressure:

Plastic bowl: 150 psig (10 bar) maximum.  
Metal bowl: 200 psig (14 bar) maximum.

**Oil Adjustment:** External.

**Seals:** Nitrile.

## FLOW CHART

Inlet Pressure: 100 psig (7 bar)

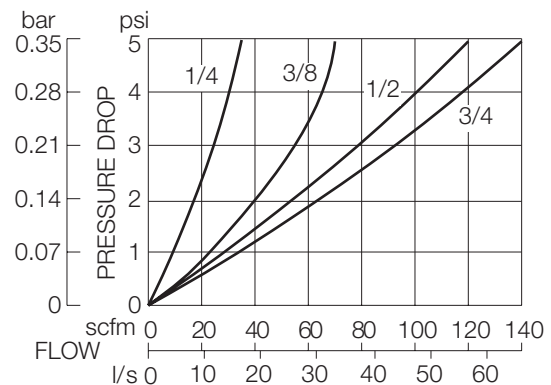

Minimum Flow: 6 scfm (2.8 l/s)

**DIMENSIONS** inches (mm)

Bowl	A	B	C	Depth	Weight lb (kg)
Plastic	3.5 (89)	5.2 (132)	0.7 (17)	3.5 (89)	2.25 (1.02)
Metal	3.5 (89)	5.3 (135)	0.7 (17)	3.5 (89)	2.85 (1.30)

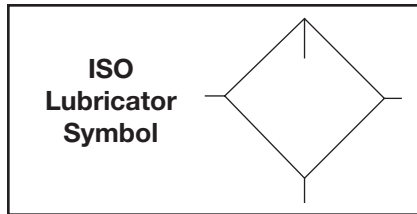
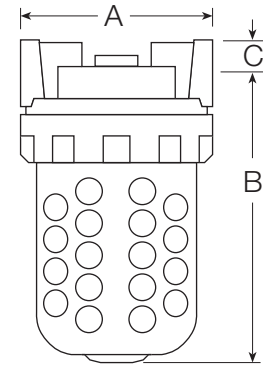

**ORDERING INFORMATION**

Change the letters in the sample model number below to specify the lubricator you want.

**L28W - 2 Y W**

<p><b>BOWL TYPE</b></p> <p>8-Ounce plastic .....L28W 8-Ounce metal .....BL28W</p> <p><b>PORT SIZE</b></p> <p>1/4 NPTF ..... 2 3/8 NPTF ..... 3 1/2 NPTF ..... 4 3/4 NPTF ..... 6 9/16-18 UNF SAE ..... S6 3/4-16 UNF SAE ..... S8 7/8-14 UNF SAE ..... S10</p>	<p><b>PORT TYPE</b></p> <p>NPTF Threads ..... Leave Blank BSPP threads ..... W</p> <p><b>OPTIONS</b></p> <p>None ..... Leave Blank Quick-fill Q-cap..... Q</p>
--	--

# Full-Size SERIES 380 Modular Lubricators

# L380D Models Port Sizes: 3/8, 1/2, 3/4

### Available Color Caps

Yellow  
(optional)



Red  
(optional)



Blue  
(optional)



Grey  
(standard)



Model Shown: L380D-6

## SPECIFICATIONS

### Ambient/Media Temperature:

Plastic bowl: 40° to 125°F (4° to 52°C).  
Metal bowl: 40° to 175°F (4° to 79°C).

**Body:** Zinc.

**Bowl:** 9-Ounce (270-ml) capacity polycarbonate plastic with steel shatterguard; optional aluminum bowl with clear nylon sight glass.  
Optional 15-ounce (450-ml) extended aluminum bowl with two clear nylon sight glasses.

**Bowl Ring:** Nylon.

**Cap Color:** Accent grey. Yellow, red, and blue optional.

**Fluid Media:** Compressed air.

### Inlet Pressure:

Plastic bowl: 150 psig (10 bar).  
Metal bowl: 200 psig (14 bar).

**Oil Adjustment:** External; tamper resistant.

**Seals:** Nitrile.

**Sight-Feed Dome:** Nylon.

- ◆ Modular or inline mounting.
- ◆ Sight-feed design; transparent dome shows how much oil is being dispensed.
- ◆ External adjusting knob, removable for tamper resistance.
- ◆ Polycarbonate plastic bowl with steel shatter-guard; optional aluminum bowl with sight glass.
- ◆ Optional extended metal bowl.
- ◆ All working parts can be replaced with a single service cartridge.
- ◆ NPTF port threads; optional SAE or BSPP threads.

## FLOW CHARTS

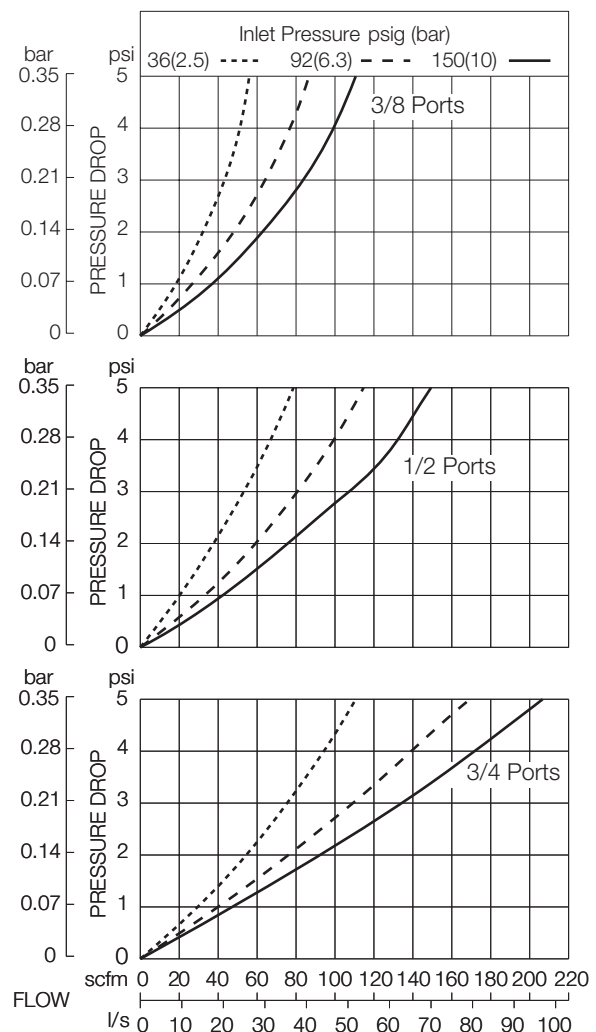

## DIMENSIONS inches (mm)

Bowl	A	B †	C	Depth	Weight lb (kg)
9-Ounce Plastic	3.5 (88)	7.1 (179)	2.2 (56)	2.9 (73)	2.0 (0.91)
9-Ounce Metal	3.5 (88)	7.4 (188)	2.2 (56)	3.1 (79)	2.0 (0.91)
Extended Metal	3.5 (88)	10.6 (269)	2.2 (56)	3.1 (79)	2.2 (1.00)

† Bowl removal clearance: add 3.1 (79) for 9-ounce bowl; 6.1 (155) for extended bowl.

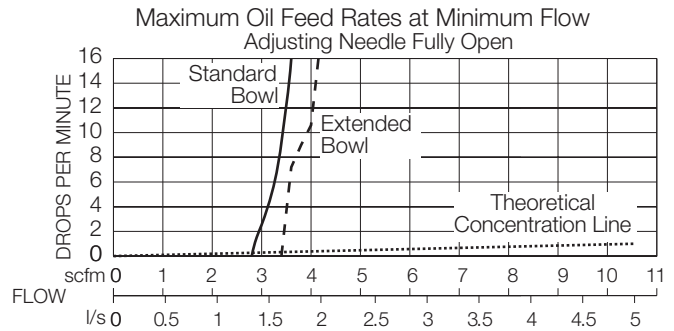
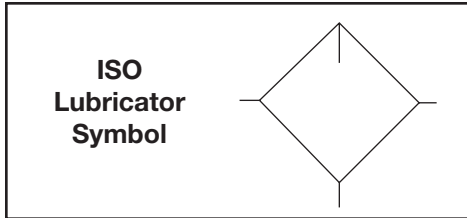
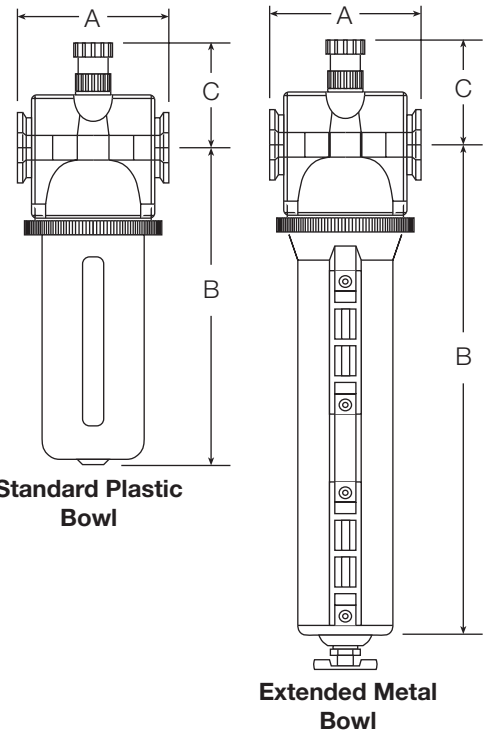

## ORDERING INFORMATION

Change the letters in the sample model number below to specify the lubricator you want.

**L380D - 3**

**BOWL TYPE**

- 9-Ounce plastic ..... L380D
- 9-Ounce metal ..... BL380D
- 15-Ounce metal ..... BL380DH

**PORT SIZE**

- 3/8 NPTF ..... 3
- 1/2 NPTF ..... 4
- 3/4 NPTF ..... 6
- 3/4-16 UNF SAE ..... S8
- 7/8-14 UNF SAE ..... S10

**Y W**

### PORT TYPE

NPTF Threads ..... Leave Blank  
BSPP threads ..... W

### OPTIONS

None ..... Leave Blank  
Cap color: Grey is standard.  
MP yellow ..... C1  
Red ..... C2  
Mid blue ..... C3  
Quick-fill Q-cap ..... Q

# High-Capacity VANGUARD Lubricators

# L29D Models Port Sizes: 3/4 to 1-1/2



Model Shown: L29D-8

- ◆ Inline mounting.
- ◆ High-strength polycarbonate plastic bowl with steel shatterguard. Optional aluminum bowl with sight glass.
- ◆ Sight-feed design.
- ◆ External adjusting knob; removable for tamper resistance.
- ◆ Optional low level switch is available on metal bowls
- ◆ NPTF port threads; optional SAE or BSPP threads.

## SPECIFICATIONS

### Ambient/Media Temperature:

Plastic bowl: 40° to 125°F (4° to 52°C).

Metal bowl: 40° to 175°F (4° to 79°C).

**Body:** Aluminum.

**Bowl:** 16-Ounce (480-ml) capacity polycarbonate plastic with steel shatterguard. Optional aluminum bowl with sight glass.

**Bowl Ring:** Aluminum.

**Fluid Media:** Compressed air.

### Inlet Pressure:

Plastic bowl: 150 psig (10 bar) maximum.

Metal bowl: 200 psig (14 bar) maximum.

**Oil Adjustment:** External, tamper-resistant.

**Seals:** Nitrile.

**Sight Dome:** Nylon.

## FLOW CHART

Inlet Pressure: 100 psig (7 bar)

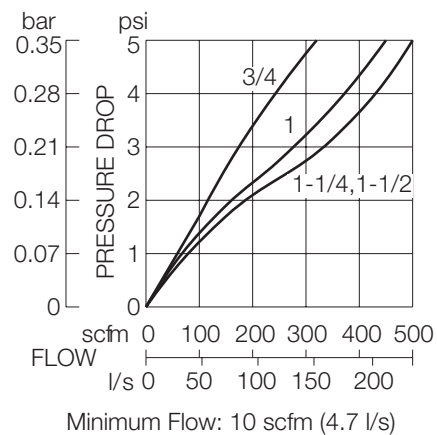



**DIMENSIONS** inches (mm)

Bowl	A	B	C	Depth	Weight lb (kg)
Plastic	4.3 (108)	8.2 (208)	1.4 (37)	4.2 (106)	2.63 (1.21)
Metal	4.3 (108)	7.3 (185)	1.4 (37)	4.2 (106)	2.85 (1.30)

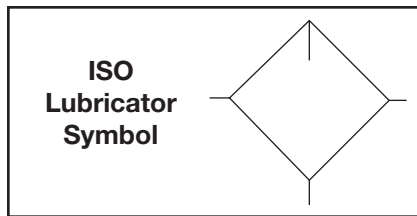
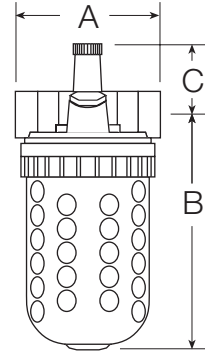

**ORDERING INFORMATION**

Change the letters in the sample model number below to specify the lubricator you want.

**L29D - 6 Y W**

<p><b>BOWL TYPE</b></p> <p>Plastic ..... L29D</p> <p>Metal BL29D</p>	<p><b>PORT TYPE</b></p> <p>NPTF Threads ..... Leave Blank</p> <p>BSP threads ..... W</p>
<p><b>PORT SIZE</b></p> <p>3/4 NPTF ..... 6</p> <p>1 NPTF ..... 8</p> <p>1-1/4 NPTF ..... 10</p> <p>1-1/2 NPTF ..... 12</p> <p>1-1/16-12 UNF SAE ..... S12</p> <p>1-5/16-12 UNF SAE ..... S16</p> <p>1-5/8-12 UNF SAE ..... S20</p> <p>1-7/8-12 UNF SAE ..... S24</p>	<p><b>OPTIONS</b></p> <p>None ..... Leave Blank</p> <p>Quick-fill Q-cap ..... Q</p> <p>Low level switch; ..... S</p> <p>only available with metal bowl option</p>

# High-Capacity VANGUARD Lubricators

# L100 Models Port Sizes: 3/4, 1



Model Shown: L100-8

- ◆ Inline mounting.
- ◆ High-strength polycarbonate plastic bowl with steel shatterguard. Optional aluminum bowl with sight glass.
- ◆ Wick-feed design.
- ◆ Internal adjustment.
- ◆ **NPTF** port threads; optional **SAE** or **BSPP** threads.

## SPECIFICATIONS

### Ambient/Media Temperature:

Plastic bowl: 40° to 125°F (4° to 52°C).

Metal bowl: 40° to 175°F (4° to 79°C).

**Body:** Aluminum.

**Bowl:** 16-Ounce (480-ml) capacity polycarbonate plastic with steel shatterguard. Optional aluminum bowl with sight glass.

**Bowl Ring:** Aluminum.

**Fluid Media:** Compressed air.

### Inlet Pressure:

Plastic bowl: 150 psig (10 bar) maximum.

Metal bowl: 200 psig (14 bar) maximum.

**Oil Adjustment:** Internal.

**Seals:** Nitrile.

**Sight Dome:** Nylon.

## FLOW CHART

Inlet Pressure: 100 psig (7 bar)

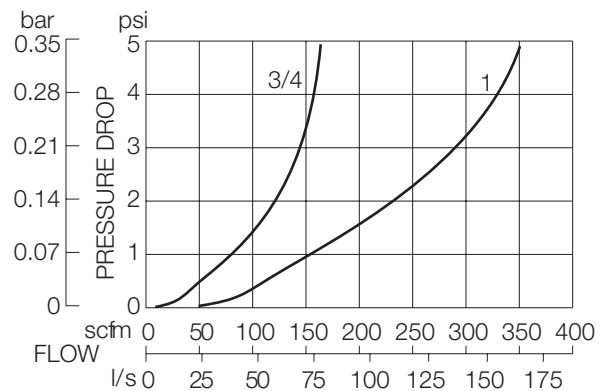

**Minimum Flow:** 3/4 port, 25 scfm (12 l/s)  
1 port, 35 scfm (16 l/s)

**DIMENSIONS** inches (mm)

Bowl	A	B	C	Depth	Weight lb (kg)
Plastic	4.5 (114)	7.7 (195)	0.8 (21)	4.2 (106)	2.88 (1.31)
Metal	4.5 (114)	8.2 (208)	0.8 (21)	4.2 (106)	3.00 (1.36)

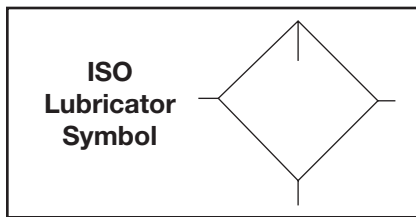
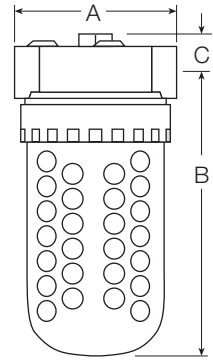

**ORDERING INFORMATION**

Change the letters in the sample model number below to specify the lubricator you want.

**L100 - 6 Y W**

<p><b>BOWL TYPE</b></p> <p>Plastic ..... L100</p> <p>Metal.....BL100</p> <p><b>PORT SIZE</b></p> <p>3/4 NPTF..... 6</p> <p>1 NPTF ..... 8</p> <p>1-1/16-12 UNF SAE ..... S12</p> <p>1-5/16-12 UNF SAE ..... S16</p>	<p><b>PORT TYPE</b></p> <p>NPTF Threads ..... Leave Blank</p> <p>BSP threads ..... W</p> <p><b>OPTIONS</b></p> <p>None ..... Leave Blank</p> <p>Quick-fill Q-cap..... Q</p>
---	---

# High-Capacity VANGUARD Lubricators

# BL237D Models Port Sizes: 3/4 to 1-1/2



Model Shown: BL237D-12

- ◆ Inline mounting.
- ◆ Aluminum bowl with sight glass. Optional extended bowl.
- ◆ Sight-feed design.
- ◆ External adjusting knob; removable for tamper resistance.
- ◆ Optional low level switch is available
- ◆ NPTF port threads; optional SAE or BSPP threads.

## SPECIFICATIONS

**Ambient/Media Temperature:**

40° to 175°F (4° to 79°C).

**Body:** Aluminum.

**Bowl:** 35-Ounce (1030-ml) capacity aluminum bowl with sight glass. Optional 62-ounce (1830-ml) extended aluminum bowl with two sight glasses.

**Bowl Ring:** Aluminum.

**Fluid Media:** Compressed air.

**Inlet Pressure:** 200 psig (14 bar) maximum.

**Oil Adjustment:** External, tamper-resistant.

**Seals:** Nitrile.

## FLOW CHART

Inlet Pressure: 100 psig (7 bar)

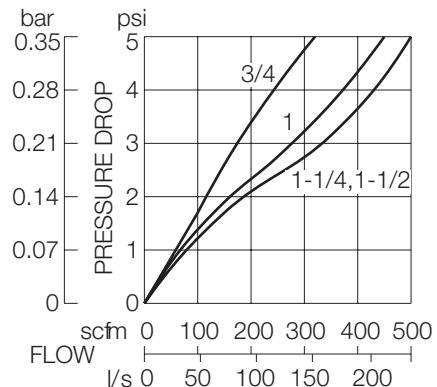

Minimum Flow: 35-Ounce bowl, 10 scfm (4.7 l/s)  
62-Ounce bowl, 14 scfm (6.6 l/s)

**DIMENSIONS** inches (mm)

Port	A	B	C	Depth	Weight lb (kg)
3/4	4.3	10.2	2.0	4.2	2.56
1	(108)	(259)	(51)	(106)	(1.16)
1-1/4	4.3	10.6	1.6	4.2	2.56
1-1/2	(108)	(268)	(41)	(106)	(1.16)

**The following have extended bowls:**

3/4	4.3	15.8	2.0	4.2	3.38
1	(108)	(400)	(51)	(106)	(1.64)
1-1/4	4.3	16.1	1.6	4.2	3.38
1-1/2	(108)	(410)	(41)	(106)	(1.64)

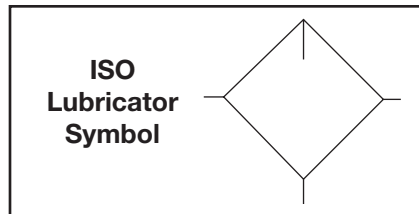
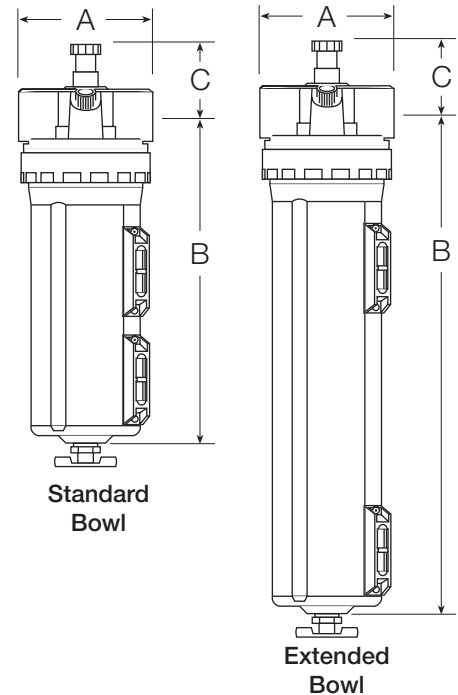

**ORDERING INFORMATION**

Change the letters in the sample model number below to specify the lubricator you want.

**BL237D - 6 Y W**

**BOWL SIZE**

Standard 35-ounce ..... BL237D  
 Extended 62-ounce.....BL237DH

**PORT SIZE**

3/4 NPTF..... 6  
 1 NPTF ..... 8  
 1-1/4 NPTF ..... 10  
 1-1/2 NPTF ..... 12  
 1-1/16-12 UNF SAE ..... S12  
 1-5/16-12 UNF SAE ..... S16  
 1-5/8-12 UNF SAE ..... S20  
 1-7/8-12 UNF SAE ..... S24

**PORT TYPE**

NPTF Threads ..... Leave Blank  
 BSPP threads ..... W

**OPTIONS**

None ..... Leave Blank  
 Quick-fill Q-cap..... Q  
 Low level switch ..... S

# SERV-OIL® INJECTION LUBRICATORS

## WHAT IS SERV-OIL?

**SERV-OIL** is the most advanced system for the precision lubrication of pneumatic equipment. It has been used for over thirty years to provide lubrication to all kinds of pneumatic equipment and various fixtures, bearings, slides, and ways. It overcomes the control problems that can be encountered with conventional mist lubricators. It also ensures proper lubrication of pneumatic components in complex circuits, and accurately delivers lubricant to points at a long distance from the lubricator.

Positive-displacement oil injectors, called Servo-Meters, are the heart of **SERV-OIL** equipment. They put pre-determined, precise amounts of oil right at the points where lubrication is needed. By comparison, mist lubricators lack the precision and control of a **SERV-OIL** system. Extensive tests have shown that when a conventional mist lubricator is installed upstream of a control valve, much of the oil dispensed by the lubricator is exhausted to atmosphere through the exhaust port of the control valve. This is inefficient, and also contributes significantly to pollution of plant air.

With **SERV-OIL** equipment the amount of oil used is greatly reduced and lubrication is more effective because of the accuracy with which the oil is delivered. Briefly: **SERV-OIL** lubricates the component, not the area!

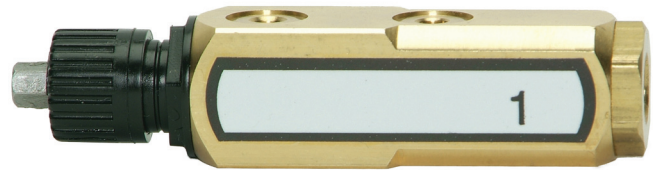

### Servo-Meter: Key Element in SERV-OIL Equipment

- ◆ Actuated by air pulse (60 psig minimum).
- ◆ Choice of 3 output ratings: 1/2, 1 or 2 drops.
- ◆ Output adjustable in small increments.
- ◆ Positive displacement metering ensures precise oil delivery with each actuation.
- ◆ Modular assembly allows up to 10 Servo-Meters to be built into a single assembly.
- ◆ Servo-Meters easily added or removed from multiple-unit assemblies.

## DO YOU NEED SERV-OIL?

If any **ONE** of the following statements describes a situation in your plant, you can reap long-term dividends by the use of **SERV-OIL** equipment.

- ◆ We repair air tools because the vanes are worn and the cylinders and rotors are scored due to insufficient lubrication.
- ◆ The appearance of fog or mist lubrication is a hazard in our plant.
- ◆ Over-lubrication costs us money because of the stringent requirements for disposing of used lubricants.
- ◆ Air cylinders in our plant become sluggish because of varnish or other contaminants.
- ◆ Torque control in our air tools is variable and doesn't meet our requirements.
- ◆ We set pressure regulators higher than the work requires just to overcome stiction in valves, cylinders, or other air components.
- ◆ If one pump fails in our lubrication system, the performance of other pumps is adversely affected.
- ◆ Sometimes lubricators are turned off, or the lubrication adjustments have been tampered with by unauthorized personnel. Such tampering removes lubrication control from the proper hands.
- ◆ We use flood coolants to lubricate taps and drills. The cost and environmental impact of this have not been considered.
- ◆ It would be to our advantage to know exactly what lubrication is being provided, and when to fill our lubricator reservoirs.

# SERVO-METER: Key SERV-OIL Module

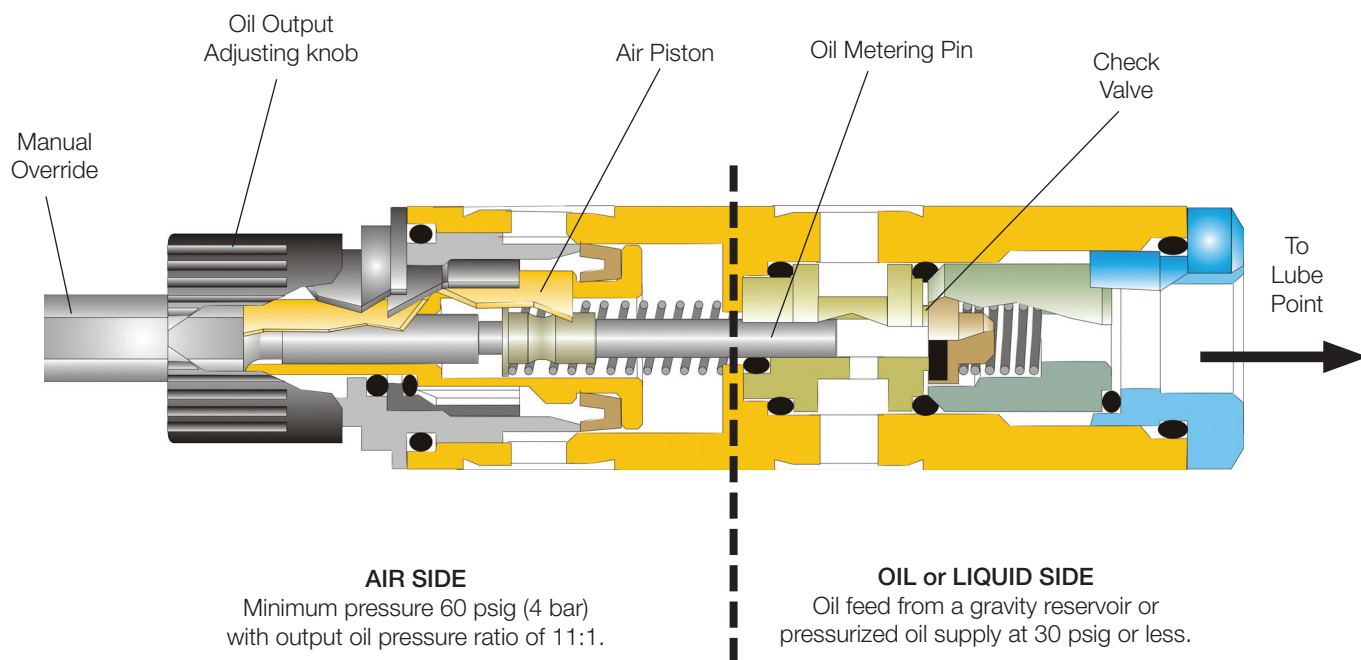

**Cutaway Drawing of SERVO-METER**

Servo-Meters are the key modules in all the **SERV-OIL** equipment. They are precision, positive-displacement liquid injectors which are actuated by an air pressure signal of at least 60 psig (4 bar). 1/8-Inch oil-filled nylon line carries the injected oil from each Servo-Meter to a point of lubrication. Servo-Meters in single-point lubricators have a flow-actuated ball in the sight indicator at one end of the Servo-Meter to give visual verification of oil delivery. Ball check valves at the ends of the nylon lines ensure that the lines and the oil sides of the Servo-Meters remain full of oil and free of air.

Servo-Meters are available in three capacities: maximum flows of 1/2 drop, 1 drop, and 2 drops. A Servo-Meter is adjustable so that the maximum amount can be reduced in increments of 1/50th of its rated capacity as shown in the following chart: (Note: 1 drop = 1/30 cc.)

Maximum Output	Reducing Increments	Minimum Output
1/2 drop	1/100 drop	1/20 drop
1 drop	1/50 drop	1/10 drop
2 drops	1/25 drop	1/5 drop

With the aid of pulse counters and the controllers described on the next page, lubrication can be reduced even further by selecting the frequency of oil injection.

**SERV-OIL** equipment described on the following pages may be designed for either single Servo-Meter service or multiple (up to twenty) Servo-Meter service. Servo-Meters are made for modular assembly so that the equipment using multiple Servo-Meters can have them added or removed very simply.

**SERV-OIL** units employing multiple Servo-Meters use the same oil supply and the same air signals. An accessory block plate can be used in a stack of Servo-Meters to allow the use of two different air signals. All the Servo-Meters will continue to use the same oil supply. See **SERV-OIL** Accessories on page 223 for further details.

Although Servo-Meters are most commonly used to inject oil, they can also be used with other liquids. Before using them with other liquids, consult Master Pneumatic for advice on such applications.

# SERVO-METER Controllers

Servo-Meters can be set to dispense widely different amounts of oil on each actuation. In addition, every SERV-OIL unit employs a controller to regulate the frequency with which the Servo-Meter(s) in the unit are actuated. This control of both the amount and frequency of lubrication makes for the greatest efficiency and economy of use of lubricants.

Controllers range from simple pulse counters to units that create the pulses that actuate the Servo-Meters.

## INTEGRATED CONTROLLERS

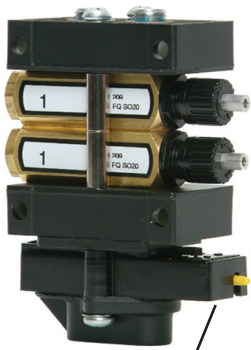

**Pneumatic Pulse  
Controller**

**Pneumatic Pulse Counter.** A multiple-point lubricator with pulse counter is shown at the left. The counter receives air pulses (usually from the output of an operating valve) and determines which of the pulses it will pass on to the Servo-Meter and so become an actuating signal. A ratcheting mechanism in the counter can be set to make an actuating signal of every pulse, every 5th pulse, or every 10th pulse.

Pulse counters can be paired in tandem so that lubrication frequency can be reduced to as little as every 100th pulse.

**Frequency Generator.** This all-pneumatic device requires a steady supply of input air, and is used most often where on-off air-input pulses are not available. From the steady air input the generator produces output pulses to actuate Servo-Meters. This type of controller is shown at the right as an integrated part of an Automation Pac assembly.

A frequency generator's output is most accurate when producing pulses with a period of 1 to 30 seconds. The generator can be combined with a pulse counter to produce a final pulse output with periods from 1 second to 5 minutes. The actuating pulse frequency in seconds of



the pulse counter and frequency generator combination is equal to the pulse counter setting (1, 5, or 10) multiplied by the frequency generator setting (1 to 30).

## STAND-ALONE CONTROLLERS



**Series PC100 Controller.** This is a stand-alone assembly of two pulse counters, and a coalescing filter to provide clean input air. A pulsed air input (usually from the output of an operating valve) is required. This controller can be used for a number of **SERV-OIL** units instead of having a counter in each of the individual units. This provides greater economy and superior control.

**Series PC110 Controller.** This is a stand-alone assembly that combines a pulse counter, a frequency generator, and a coalescing filter to provide clean input air. A steady flow of input air is required. The steady flow is converted into controlled pulses to actuate Servo-Meters.

As explained above, the settings of the pulse counter and the frequency generator can produce actuating pulses in periods as long as five minutes.

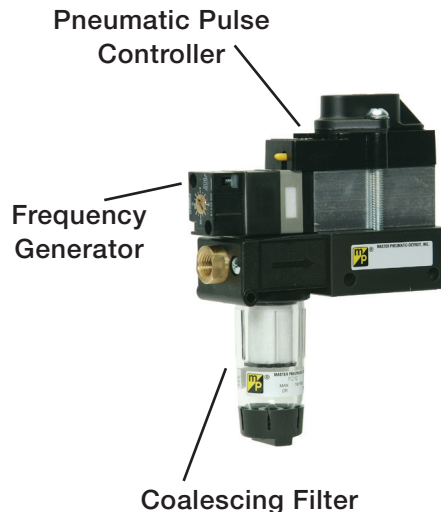



# The SERV-OIL Family of Products

## AUTOMATION PAC –

This is a self-contained assembly consisting of an oil reservoir, up to 20 Servo-Meters, and frequency controller. It is supplied ready for installation in a pneumatic circuit, with only ball checks, fittings, and tubing being required accessories. The Automation Pac will provide precision lubrication for valves, cylinders, fixtures, and machine tools using pneumatic components.



## SINGLE-POINT INJECTION LUBRICATOR for AIR TOOLS –

This unit is specifically designed to lubricate air tools. It cannot be used for other lubrication. For other single-point lubrication see the Downstream Lubricator below.



## MULTIPLE POINT INJECTION LUBRICATORS –

Up to ten Servo-Meters can be assembled to provide precision lubrication for up to ten lubrication points. All Servo-Meters use the same oil and air sources.



## SINGLE-POINT DOWNSTREAM INJECTION LUBRICATOR –

The downstream lubricator is installed in an air line going to cylinders, air motors, or other pneumatic equipment except air tools. See above for air tools. A small nylon line carries oil from the lubricator to the desired point of lubrication. Most commonly the nylon line runs inside the air line.



## LIQUID-ONLY EJECTOR –

A Servo-Meter is terminated with a nozzle through which a precise amount of liquid can be ejected up to ten inches. Assemblies of up to 10 Servo-Meters can be used.

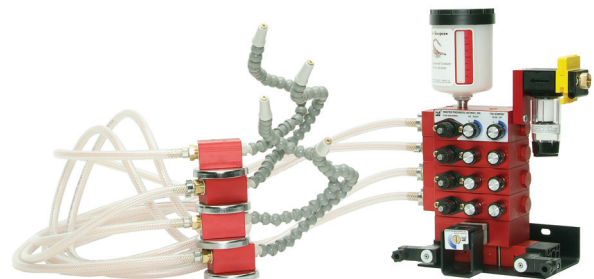

**COMPLETE LUBRICATION SYSTEMS** – All-in-one lubrication or coolant systems are engineered for many specialized requirements. See the descriptions of the **SCORPION** and **VIPER** systems at the end of this section.

# PNEUMATIC TOOL LUBRICATION

## The Best Way to Do It!

### CONVENTIONAL MIST LUBRICATION

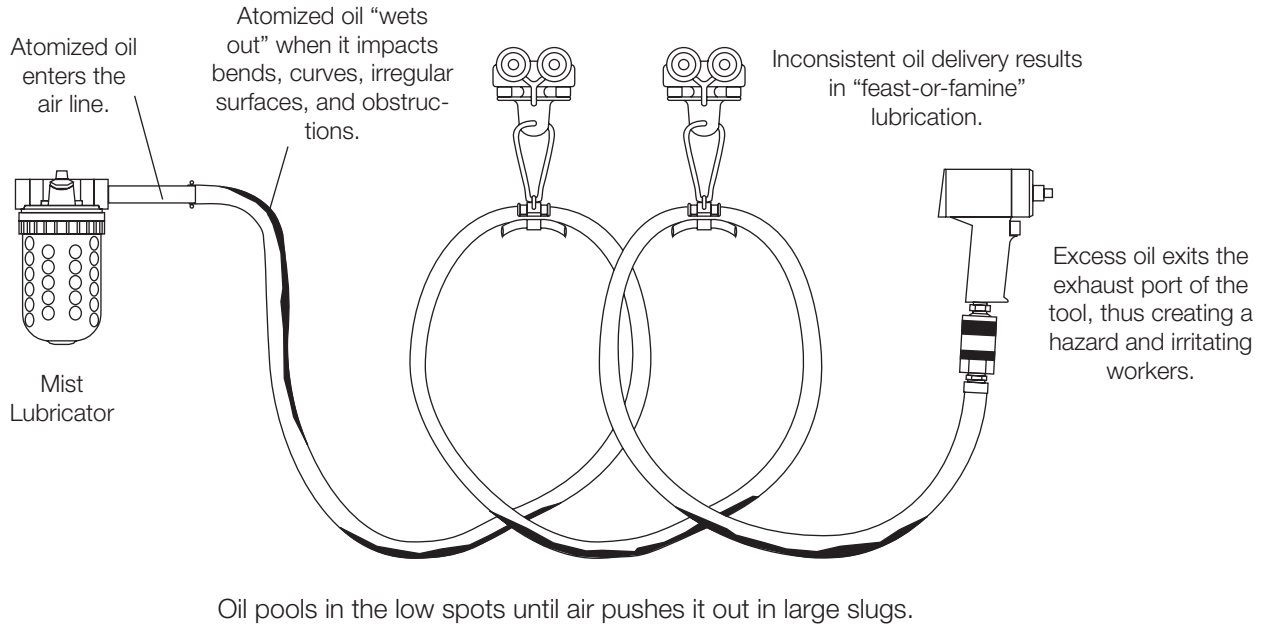

### INJECTION LUBRICATION

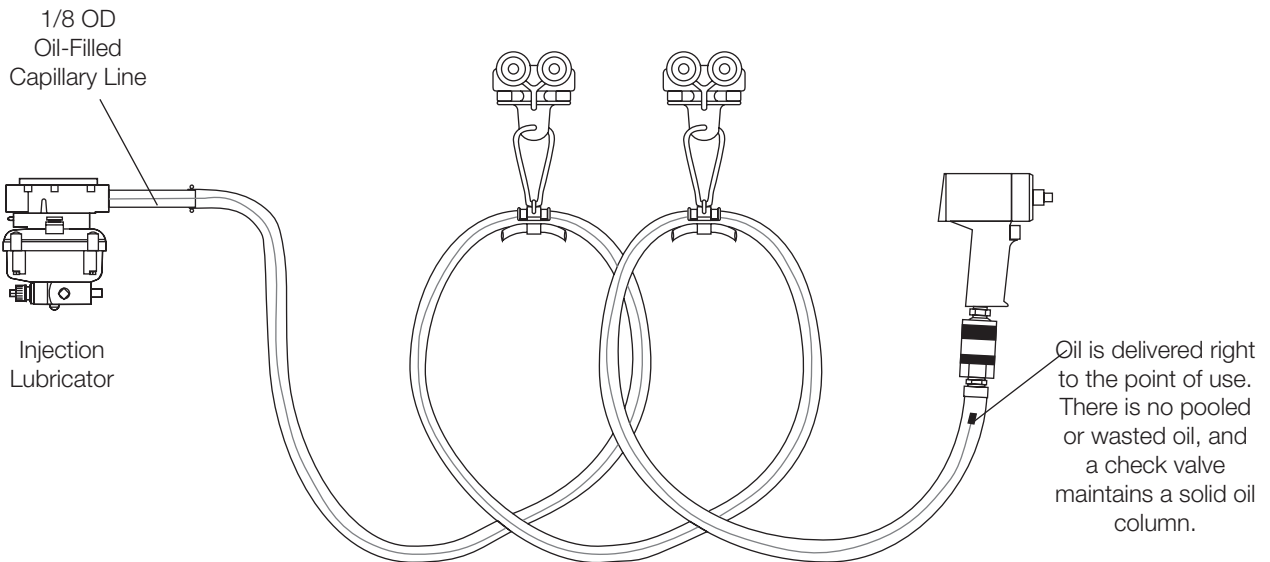

Consistant, Precision Lubrication Results in Consistent Torque and Tool Performance.

# The Importance of SERV-OIL to Air Tools

Air tools are very economical devices for tightening threaded fasteners. They are usually smaller and lighter than similar electric or hydraulic tools, and have the advantage of being able to stall without suffering motor damage. However, understanding the mechanics of an air tool will make it clear why it requires consistent, controlled lubrication.

## CONSTRUCTION

The most common motor design used in air tools is the rotary vane type. A typical cross section of such a motor is shown below.

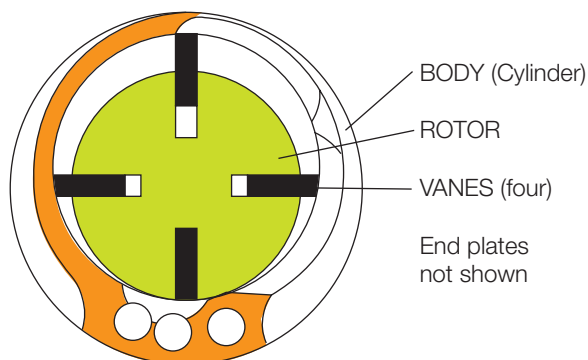

The motor body is usually of cast metal. Its inside diameter and is machined and polished to a high finish. The diameter and length of the body will determine the size and capacity of the motor. The rotor's diameter is about 85% of the inside diameter of the body, and has radial slots to accommodate the four vanes. The vanes are as long as the rotor, and are linen-based, phenolic resin strips. The two end plates are made of a soft metal. They support the rotor shaft and serve as dynamic seals.

Note that the cylinder inside diameter and the rotor diameter have different center points. The difference is such that the two surfaces will be tangent where the bottom of the rotor touches the cylinder. Note also that the vanes slide in the rotor slots so that they maintain contact with the cylinder. This contact can be maintained by springs beneath each vane, or, more commonly, by air pressure.

## WORK CYCLE

Referring to the diagram below we can follow a work cycle of the air motor.

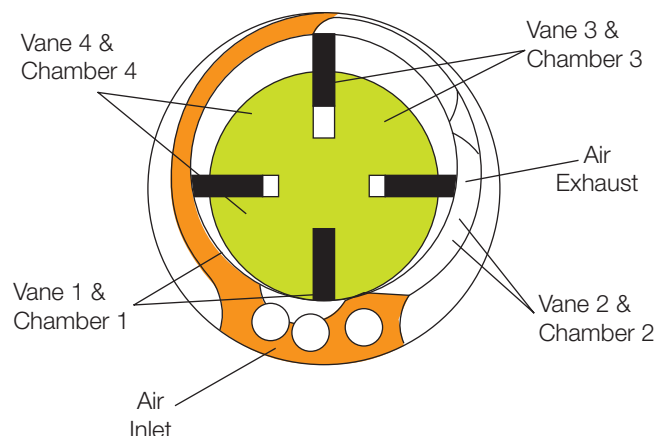

Vaness divide the space between the rotor and cylinder into four chambers. Chamber 1 includes the inlet port. When pressurized air enters chamber 1 it causes the rotor to turn clockwise. When vane 2 clears the inlet port, chamber 2 is pressurized and the rotation to continues. As each chamber reaches the exhaust port its pressure is exhausted. A positive pressure differential between the chambers on the left and those on the right must be maintained in order for the rotor to rotate.

Maintaining a good seal between chambers is the function of the vanes. The most important seal points are where the vanes contact the cylinder, with the seal of the bottom vane being the most critical. It is here that the pressure differential between the inlet and exhaust sides of the motor must be maintained. If the seal points leak, the pressure differential drops, and the motor loses torque.

The wear of the seals is magnified by hit-or-miss lubrication. Without oil the vanes take a beating, and eventually crack and chip. The chips score the cylinder and rotor, and may even wedge themselves between vanes and cylinder. The air motor is approaching uselessness!

The **SERV-OIL** Single Point Lubricator is specifically designed to inject a predetermined amount of oil at the inlet of the air tool every time it cycles. Maximum performance. Extended life. Reduced maintenance. Less downtime. Improved torque control. These are all the result of **PRECISE, CONSISTENT LUBRICATION.**

# SERV-OIL Single-Point Injection Lubricators for Air Tools

Port Sizes: 1/2, 3/4



Model Shown: A64061

## SPECIFICATIONS

**Air Flow:** Maximum inlet pressure of 150 psig (10 bar) and a pressure drop of 3 psi (0.2 bar):

1/2 NPTF — 60 scfm (28 dm<sup>3</sup>/s)

3/4 NPTF — 90 scfm (43 dm<sup>3</sup>/s)

**Ambient/Media Temperature:**

40° to 125°F (4° to 52°C).

**Flow Valve:** Zinc body.

**Operating Pressure Range:**

60-150 psig (4.1-10.3 bar)

**Pulse Counter:** Adjustable to operate the Servo-Meter on every cycle, every 5th cycle, or every 10th cycle.

**Reservoir:** Integral, unpressurized. 10-Ounce (300-ml) capacity transparent nylon with quick-fill cap. Optional M476R reservoir. Integral reservoir can be eliminated if a central-fill system is employed

**Servo-Meter:** Aluminum body; acetal end caps. 1-Drop rating; optional 1/2-drop or 2-drop rating. Transparent sight indicator gives visual verification of oil delivery.

**Tubing:** Optional 25 feet (8 meters) of oil-filled tubing.

The single-point lubricator (**SPL**) is specifically designed to lubricate air tools. It cannot be used for general lubrication of components other than air tools. For other single-point applications see the single-point downstream lubricator on the following pages.

An **SPL** is installed in the air supply line upstream of the air tool. When the tool is cycled the **SPL** injects a precise amount of oil at the air inlet of the tool. Both the amount of oil and the frequency of injection are adjustable.

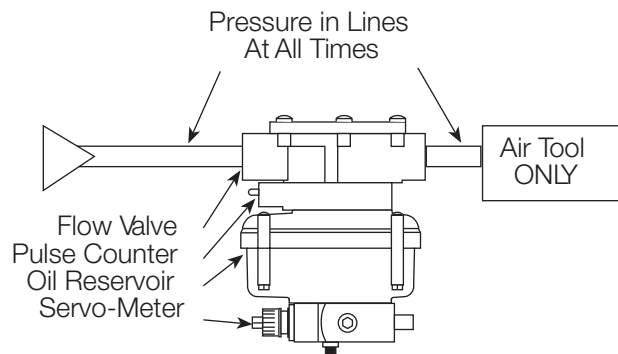

Sub-Assemblies and Installation of SPL

The four sub-assemblies shown in the drawing above make up the **SPL**.

**Flow Valve.** The air supply line is connected to the inlet of the flow valve. 1/8-Inch nylon tubing is connected to the nozzle in the outlet port, and then runs inside or outside the air line to within a short distance of the air tool.

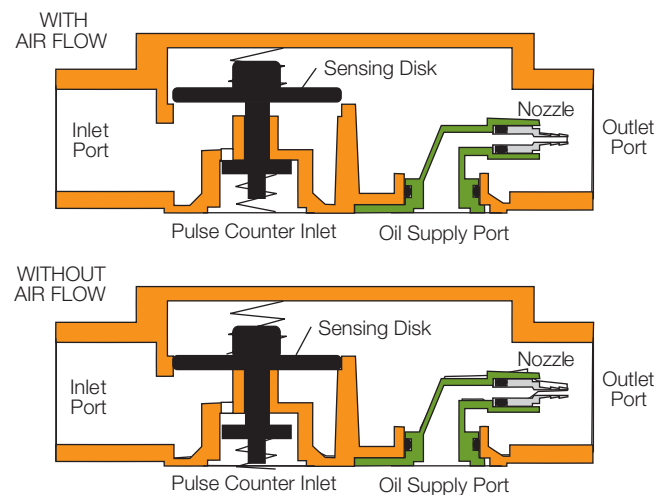

SPL Flow Valve

(continued on next page)

When the air tool is at rest, no air flows in the valve. When the tool is triggered the differential pressure across the sensing disk opens a passage to the pulse counter.

**Pulse Counter.** When the air tool is triggered the pulse counter receives an air signal from the flow valve. A three-position switch on the counter is set to allow the air signal to proceed to the Servo-Meter on every cycle, every 5th cycle, or every 10th cycle. This is one of the means of controlling the amount of lubrication that will be supplied to the air tool.

**Servo-Meter.** The Servo-Meter is an air-actuated, positive-displacement oil pump. It injects oil with each signal from the pulse counter. These signals can be every time, every 5th time, or every 10th time the air tool is triggered. The frequency is determined by the setting of the pulse counter.

To actuate the Servo-Meter the signal received must have a pressure of at least 60 psig (4 bar). When actuated the Servo-Meter delivers a precise amount of oil to the nozzle in the outlet port of the flow valve, and is then carried by a nylon line to the air tool. A transparent sight indicator on one end of the Servo-Meter gives visual verification of oil delivery.

By means of the adjusting knob on the end of the Servo-Meter, oil delivery can be reduced in increments of 1/50th of the maximum rating down to 1/10th of the maximum rating.

**Oil Reservoir.** The integral oil reservoir is made of tough, transparent nylon, and has a capacity of 10 ounces (300 ml). It has a quick-fill cap, and since the reservoir is not pressurized it can be filled at any time. It can also be used with a central-fill system. Gravity fill is recommended, but fill pressure can be up to 30 psig (2 bar).

An SPL can be ordered without an integral reservoir, in which case a sight-dome air eliminator is available for use with a central-fill system.

**DIMENSIONS** inches (mm)

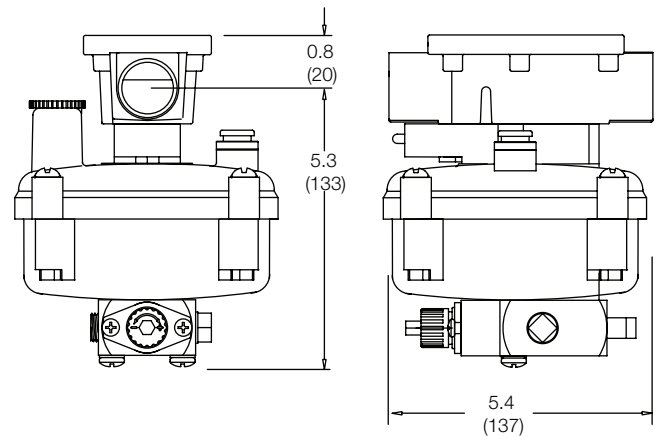

**To determine lubrication rates refer to page 289.**

**ORDERING INFORMATION**

Change the letters in the sample model number below to specify the **SPL** you want.

**P A6 4 0 4 1 Y W**

**OIL-FILLED TUBING**

With 25 ft (8 m) of tubing ... Leave Blank  
Without tubing..... P

**RESERVOIR**

With integral reservoir ..... 4  
No integral reservoir. Also specify  
0 if ordering M476R reservoir  
under **OPTIONS** at right ..... 0

**PORT SIZE**

1/2 NPTF..... 4  
3/4 NPTF..... 6

**PORT TYPE**

NPTF Threads ..... Leave Blank  
BSPP threads ..... W

**OPTIONS** (*More than one option can be chosen*)

None ..... Leave Blank  
Two pulse counters ..... BB  
Frequency controller ..... F  
M476R reservoir. Also specify 0  
under **RESERVOIR** at left..... R

**SERVO-METER RATING**

One drop..... 1  
Two drops ..... 2  
Half drop ..... 5

# SERV-OIL Downstream Injection Lubricators for Equipment *except* Air Tools

Port Sizes: 1/2, 3/4



Model Shown: D64061

## SPECIFICATIONS

**Air Flow:** Maximum inlet pressure of 150 psig (10 bar) and a pressure drop of 3 psi (0.2 bar):

1/2 NPTF — 60 scfm (28 dm<sup>3</sup>/s)

3/4 NPTF — 90 scfm (43 dm<sup>3</sup>/s)

**Ambient/Media Temperature:**

40° to 125°F (4° to 52°C).

**Flow Valve:** Zinc body.

**Operating Pressure Range:**

60-150 psig (4.1-10.3 bar)

**Pulse Counter:** Adjustable to operate the Servo-Meter on every cycle, every 5th cycle, or every 10th cycle.

**Reservoir:** Integral, unpressurized. 10-Ounce (300-ml) capacity transparent nylon with quick-fill cap. Optional M476R reservoir. Integral reservoir can be eliminated if a central-fill system is employed

**Servo-Meter:** Aluminum body; acetal end caps. 1-Drop rating; optional 1/2-drop or 2-drop rating. Transparent sight indicator gives visual verification of oil delivery.

**Tubing:** Optional 25 feet (8 meters) of oil-filled tubing.

The downstream injection lubricator is specifically designed to overcome the shortcomings of the conventional mist lubricator installed upstream of a control valve. Laboratory and field tests have shown that a mist lubricator installed in the conventional manner results in much of the lubricating oil being exhausted to atmosphere through the exhaust port of the control valve.

Oil that passes through the valve tends to coalesce and cling to the wall of the air line where it simply moves back and forth with each valve cycle.

The SERV-OIL downstream injection lubricator eliminates these shortcomings. It is installed downstream of the control valve and uses a small nylon line to carry the lubricant right to the desired lubrication point. This assures dependable lubrication for cylinders, air motors, or other pneumatic equipment.

The downstream lubricator is not designed to work with air tools. For such applications see preceding pages .

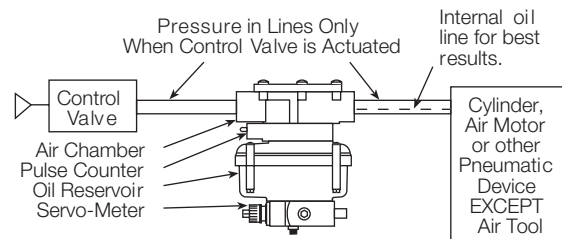

Sub-Assemblies and Installation of Downstream Lubricator

The four sub-assemblies shown in the drawing above make up the downstream lubricator.

**Air Chamber.** The air line supplying the cylinder (or other device to be lubricated) is connected to the inlet port of the air chamber. 1/8-Inch nylon tubing is connected to the nozzle in the outlet port, and then runs inside the air line to within a short distance of the cylinder port. A check valve can be installed at the end of the tubing to prevent air from entering the system.

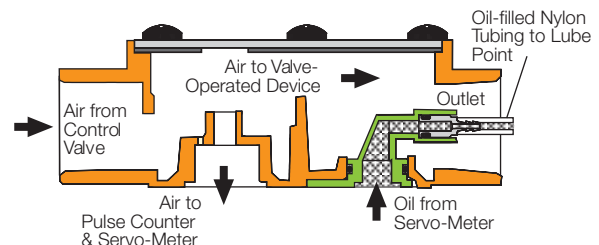

Air Chamber of Downstream Lubricator

**Pulse Counter.** When the control valve is actuated the pulse counter receives an air signal from the air chamber. A three-position switch on the counter is set to allow the air signal to proceed to the Servo-Meter on every cycle, every 5th cycle, or every 10th cycle. This is one of the means of controlling the amount of lubrication that will be dispensed by the Servo-Meter.

**Servo-Meter.** The Servo-Meter is an air-actuated, positive-displacement oil pump. It injects oil with each signal from the pulse counter. These signals can be every time, every 5th time, or every 10th time the control valve is actuated. The frequency is determined by the setting of the pulse counter.

To actuate the Servo-Meter the signal received must have a pressure of at least 60 psig (4 bar). When actuated the Servo-Meter delivers a precise amount of oil to the nozzle in the outlet port of the flow valve, and thus on to the lubrication point. A transparent sight indicator on one end of the Servo-Meter gives visual verification of oil delivery.

By means of the adjusting knob on the end of the Servo-Meter, oil delivery can be reduced in increments of 1/50th of the maximum rating down to 1/10th of the maximum rating.

**Oil Reservoir.** The integral oil reservoir is made of tough,

transparent nylon, and has a capacity of 10 ounces (300 ml). It has a quick-fill cap, and since the reservoir is not pressurized it can be filled at any time. It can also be used with a central-fill system. Gravity fill is recommended, but fill pressure can be up to 30 psig (2 bar).

A downstream lubricator can be ordered without an integral reservoir, in which case a sight-dome air eliminator is available for use with a central-fill system.

**DIMENSIONS** inches (mm)

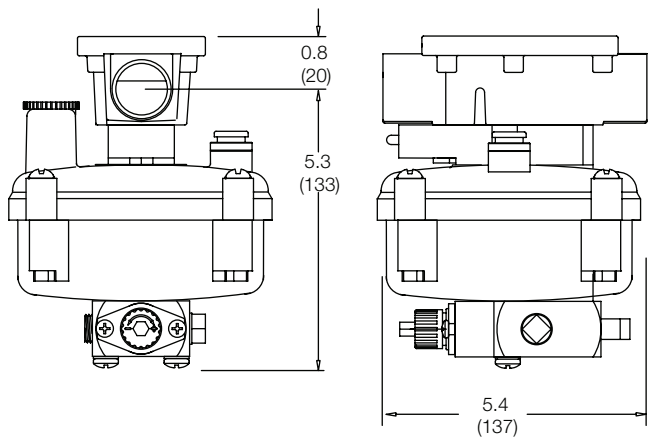

**To determine lubrication rates refer to page 289.**

**ORDERING INFORMATION**

Change the letters in the sample model number below to specify the downstream lubricator you want.

**P D6 4 0 4 1 Y W**

- OIL-FILLED TUBING**
  - With 25 ft (8 m) of tubing ... Leave Blank
  - Without tubing..... P
- RESERVOIR**
  - With integral reservoir ..... 4
  - No integral reservoir. Also specify 0 if ordering M476R reservoir under **OPTIONS** at right ..... 0
- PORT SIZE**
  - 1/2 NPTF..... 4
  - 3/4 NPTF..... 6

- PORT TYPE**
  - NPTF Threads ..... Leave Blank
  - BSP threads ..... W
- OPTIONS** (*More than one option can be chosen*)
  - None ..... Leave Blank
  - Two pulse counters ..... BB
  - Frequency controller ..... F
  - M476R reservoir. Also specify 0 under **RESERVOIR** at left..... R
- SERVO-METER RATING**
  - One drop..... 1
  - Two drops ..... 2
  - Half drop ..... 5

# PNEUMATIC CYLINDER LUBRICATION

## Extend Cylinder Life and Decrease Downtime

### CONVENTIONAL MIST LUBRICATION

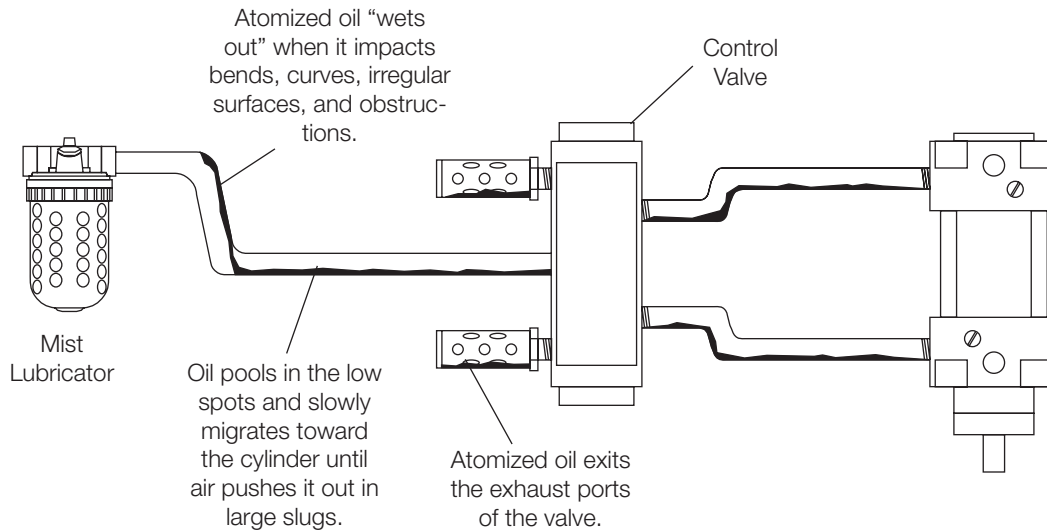

### INJECTION LUBRICATION

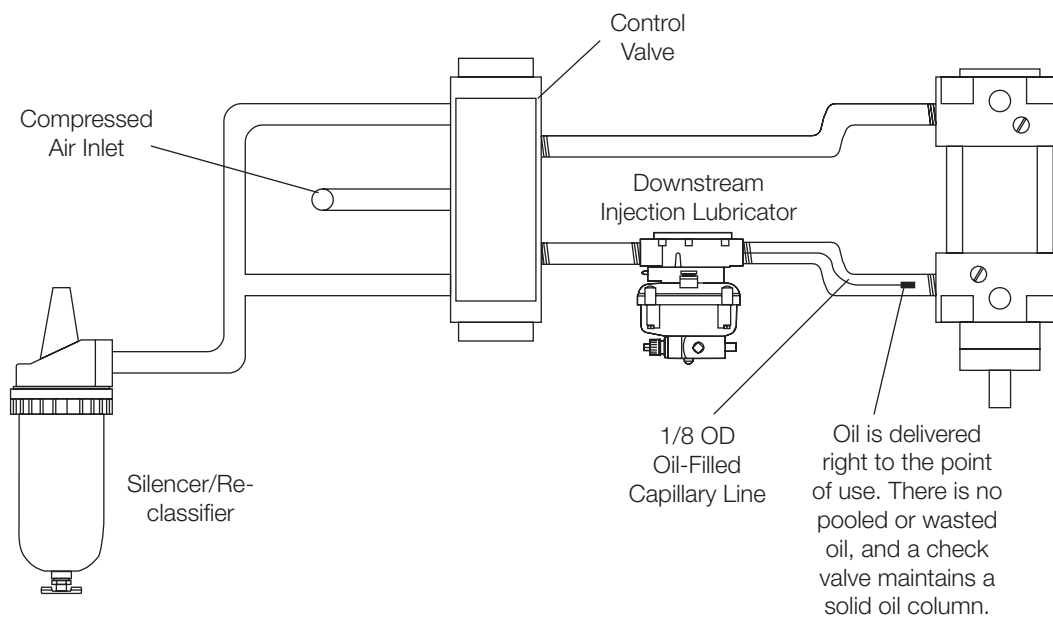



# Cylinder Lubrication: Mist vs. SERV-OIL

A test was conducted for a major automotive plant to compare the effectiveness of mist type and SERV-OIL injection type lubricators. The test used special dual lip piston weld cylinders, and was conducted over a period of three and a half months. Cylinders were run for approximately 14 hours at a time. Both types of lubricators were adjusted to dispense the equivalent of one-tenth drop of oil for each 10 cylinder cycles.

Triple-filtered air was used in this test, and when the cylinders were disassembled at the end of the test no visible foreign particles were found in the cylinders. Filtration was at the 0.3- $\mu$ m level, and this is much finer than is found in most air cylinder operations where only 40- $\mu$ m filtration is common.

At the end of each daily test run, an air flow meter was attached to each cylinder to measure rod end leakage while the cylinders were still warm. The findings are displayed in the graph below.

If the cylinders had been of conventional construction, and had air filtration been at the more common plant level (40- $\mu$ m), cylinder wear could be expected to be much greater than that recorded in this test.

With the use of **SERV-OIL** injection lubrication, it is guaranteed that lubricant is reaching the cylinder at the rod end. Oil is carried from the **SERV-OIL** injector to the lubrication point by 1/8-inch nylon tubing inside the air line. The rod, therefore, is well lubricated and as a result, due to the piston's extended resting period (usually directly under the retract air supply port), the piston also receives a beneficial delivery of lubricant.

The longer and more tortuous the air pathway from control valve to cylinder, the less effective the mist lubricator becomes. Oil tends to coalesce on the air line walls and puddle in low points. Much of the oil can also be blown into the atmosphere from the valve's exhaust port, so that it serves no purpose in lubricating the cylinder, but does create a health hazard.

Wear in the cylinder during this test is exemplified by the O-ring wear shown in the graph below.

Effect of Lubrication on Cylinder Leakage

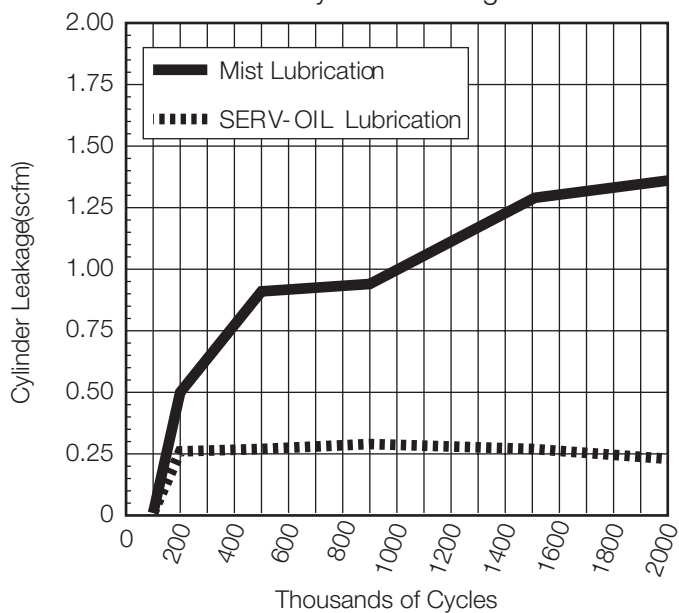

Effect of Lubrication on O-ring Wear

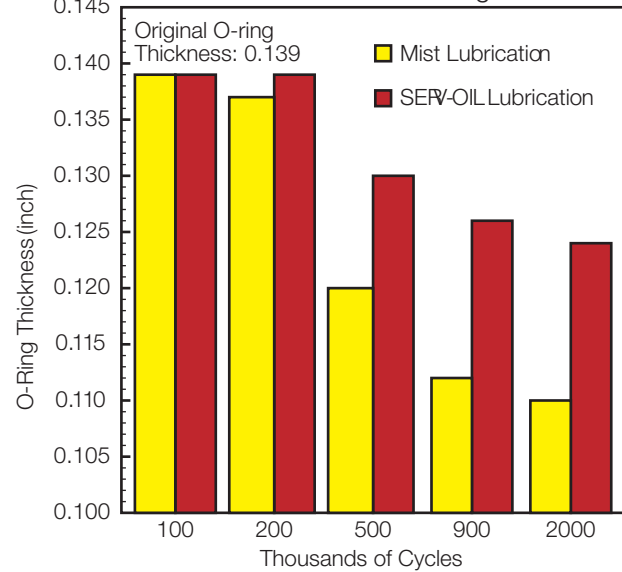

The cylinder leakage graph above displays the results at intervals up to 2 million cycles, the cycle count for the entire test. Air bypass around the piston can be seen to be significantly greater with mist type lubrication. This bypass is a failure that directly affects the force and speed of a cylinder. With **SERV-OIL** lubrication bypass loss is small, and essentially constant after establishing a low initial loss level.

As shown in this graph, an initial O-ring thickness of 0.139 inch was reduced by little more than 10% after two million cycles using **SERV-OIL** lubrication. With mist lubrication, the O-ring wear was nearly twice as great.

\* See page 289 for Cylinder Lubrication Rate chart.

## FRL and HOSE ASSEMBLIES

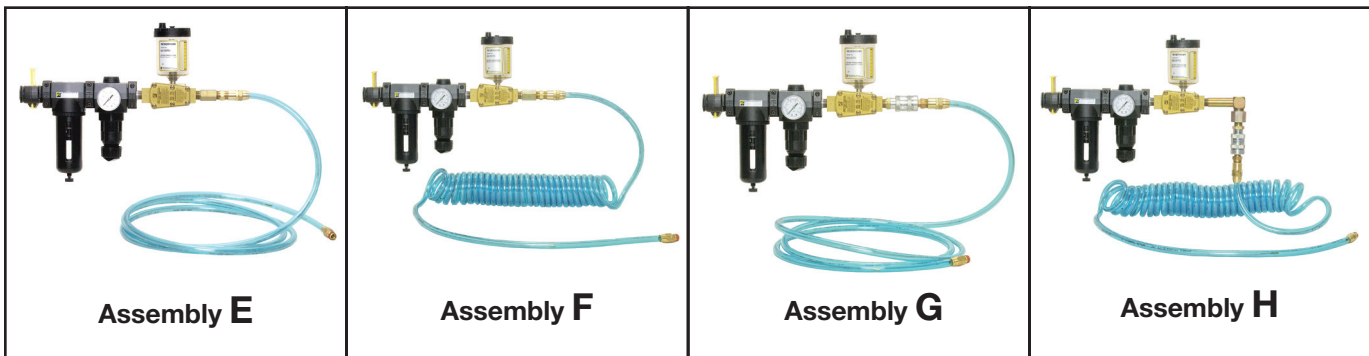
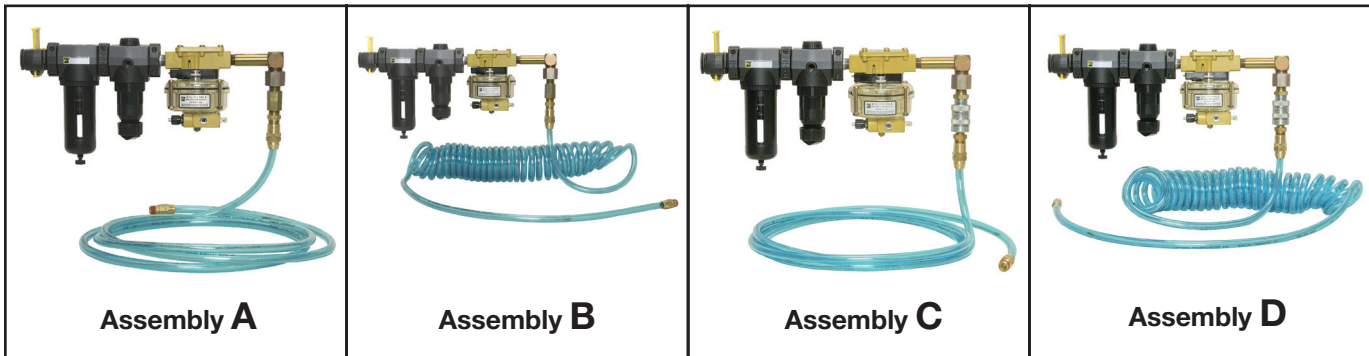

**SERV-OIL** single point lubricators (**SPLs**) have been used for decades to provide economical, precision lubrication to pneumatic devices. They lubricate just the points needing lubrication, not the hose or pipe supplying air to the device

The illustrations above are but a small sample of the available **FRL** combinations using single point lubricators. All those shown are for lubricating **AIR TOOLS** only. The injection lubricators used here are not designed for bi-directional flow, and so are **NOT** to be used with air cylinders or air motors. Where bi-directional flow is involved the downstream **SPLs** on pages 206-207 would be used.

In the above assemblies the lubricators can be fitted with integral oil reservoirs (assemblies A-D), or can be supplied from external reservoirs (assemblies E-H).

A variety of coaxial fittings and hose assemblies are available. Coaxial fittings allow the air and oil supplies to be connected simultaneously. Both quick connect/disconnect

versions and **NPT** pipe models are offered. Some assemblies (A-D and H) include a 90-degree coaxial elbow for use where the lubricator is installed overhead.

The coaxial hose assemblies are available with the internal oil capillary tube, including check valve, installed in either straight or coiled blue urethane hose. The standard hose lengths are 12-, 25-, and 50-feet. Note that the coiled assemblies have a working length less than the overall length. Working lengths are shown with the Ordering Information on page 211, 213 and 215. Other hose lengths can be made to the user's exact specifications. Consult the Master Pneumatic Sales Department.

Coiled hose assemblies are typically used in applications where the **SPL** is overhead and the amount of hose on the floor needs to be minimized.

# HOSE ASSEMBLIES

Straight Hose Assembly

Model H-0A0A3B-S12



Upstream Connection  
(From SPL)

Downstream Connection  
(To tool)

Coiled Hose Assembly

Model H-0A0A1B-C12



Upstream Connection  
(From SPL)

Downstream Connection  
(To tool)

**Upstream Connector** (Used without quick disconnect)



**Upstream Connector**  
(Used with coaxial quick disconnect socket)



## HOSE for SPLs ORDERING INFORMATION

Change the letters in the sample model number below to specify the hose assembly you want.

**H-0A0 A 1 C - C 12**

**HOSE MATERIAL**

- Urethane ..... 0
- Reinforced urethane ..... 1

**HOSE DIAMETER**

- 5/16 ID (1/2 upstream connection only) ..... A
- 3/8 ID (1/2 and 3/4 upstream connections) ..... B
- 1/2 ID (1/2 and 3/4 upstream connections) ..... C

**UPSTREAM CONNECTION**

- 1/2 coaxial plug (Used with quick disconnect) ..... 1
- 3/4 coaxial plug (Used with quick disconnect) ..... 2
- 1/2 coaxial adaptor (1/2 male threaded end) ..... 3
- 3/4 coaxial adaptor (3/4 male threaded end) ..... 4
- 1/2 NPT male (non-coax - upstream barb installed in hose) ..... 5
- 3/4 NPT male (non-coax - upstream barb installed in hose) ..... 6

**HOSE LENGTH**

- 12 ft (3.7 m); if coiled, 9 ft (2.7 m) working length ..... 12
- 25 ft (7.6 m); if coiled, 18 ft (5.5 m) working length ..... 25
- 50 ft (15 m); if coiled, 36 ft (11 m) working length ..... 50

**HOSE TYPE**

- Coiled (standard 18" upstream tail, 36" downstream tail) ..... C
- For other tail lengths, consult factory*
- Straight ..... S

**DOWNSTREAM CONNECTION**

- 3/8 male swivel (Used with 3/8 ID hose) ..... B
- 1/4 male swivel (Used with 5/16 ID hose) ..... C
- 1/2 male swivel (Used with 1/2 ID hose) ..... D

# FRL ASSEMBLY WITH SPL and HOSE

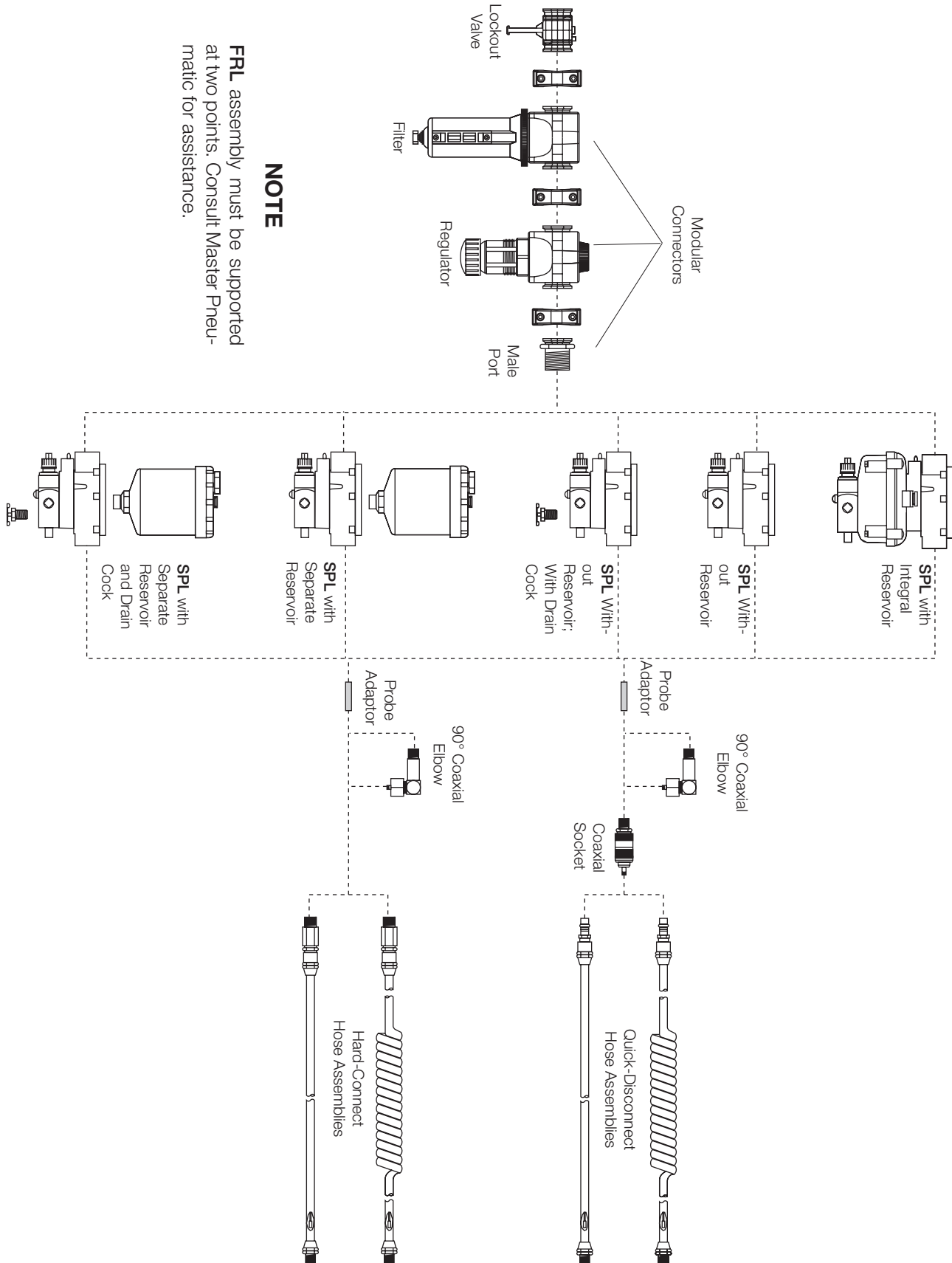

**NOTE**

FRL assembly must be supported at two points. Consult Master Pneumatic for assistance.

## FRL (with SPL) ORDERING INFORMATION

Change the letters in the sample model number below to specify the FRL assembly you want.

# HA-0 A 0 B 0 A 0 B-A00

### MODULAR LOCKOUT VALVE

None .....0  
V380 .....1

### MODULAR FILTER (See pg 48)

None .....A  
FD380 .....B  
F380 .....C  
BFD380 .....D  
BF380 .....E

### MODULAR REGULATOR (See pg 126)

None .....0  
R380-G, 0-200 psi gauge, and  
modular male port .....1  
R380 and modular male port .....2

### † LUBRICATOR (See pp 204, 206)

SM designates Servo-Meter

PA640, 1-drop SM ..... B  
PA600, 1-drop SM ..... C  
PA600, 1-drop SM, M476R reservoir ..... D  
PA600, 1-drop SM, M476R  
reservoir, 1/4 drain cock ..... E  
PA600, 1-drop SM, 1/4 drain cock ..... F  
PA640, 2-drop SM ..... G  
PA600, 2-drop SM ..... H  
PA600, 2-drop SM, M476R reservoir ..... J  
PA600, 2-drop SM, M476R  
reservoir, 1/4 drain cock ..... K  
PA600, 2-drop SM, 1/4 drain cock ..... L  
PA640, 1/2-drop SM ..... M  
PA600, 1/2-drop SM ..... N  
PA600, 1/2-drop SM, M476R reservoir ..... P  
PA600, 1/2-drop SM, M476R  
reservoir, 1/4 drain cock ..... Q  
PA600, 1/2-drop SM, 1/4 drain cock ..... R  
PD640, 1-drop SM ..... S  
PD600, 1-drop SM ..... T  
PD600, 1-drop SM, M476R reservoir ..... U  
PD600, 1-drop SM, M476R  
reservoir, 1/4 drain cock ..... V  
PD600, 1-drop SM, 1/4 drain cock ..... W  
PD640, 2-drop SM ..... X  
PD600, 2-drop SM ..... Y  
PD600, 2-drop SM, M476R reservoir ..... Z  
PD600, 2-drop SM, M476R  
reservoir, 1/4 drain cock ..... 0  
PD600, 2-drop SM, 1/4 drain cock ..... 1  
PD640, 1/2-drop SM ..... 2  
PD600, 1/2-drop SM ..... 3  
PD600, 1/2-drop SM, M476R reservoir ..... 4  
PD600, 1/2-drop SM, M476R  
reservoir, 1/4 drain cock ..... 5  
PD600, 1/2-drop SM, 1/4 drain cock ..... 6  
PA640\*1BB, 1 drop, double counter ..... 7  
PA640\*2BB, 2 drop, double counter ..... 8  
PA640\*5BB, 1/2-drop, double counter ..... 9

### PORT SIZE

1/2 NPTF .....4  
3/4 NPTF .....6

### ELBOW

None .....A  
90° coaxial elbow ..... B

### HOSE ASSEMBLIES

No hose assembly. . . . . B-A00

Assembly Number	Hose Type	Length ft (m)		Code
		Overall	Working	

#### URETHANE HOSE

**Includes 3/8 male swivel downstream connection:**

H-0A0B*B-C12	3/8 ID coiled	12 (3.7)	9 (2.7)	. . . B-C12
H-0A0B*B-C25	3/8 ID coiled	25 (7.6)	18 (5.5)	. . . B-C25
H-0A0B*B-C50	3/8 ID coiled	50 (15)	36 (11)	. . . B-C50
H-0A0B*B-S12	3/8 ID straight	12 (3.7)	12 (3.7)	. . . B-S12
H-0A0B*B-S25	3/8 ID straight	25 (7.6)	25 (7.6)	. . . B-S25
H-0A0B*B-S50	3/8 ID straight	50 (15)	50 (15)	. . . B-S50

**Includes 1/4 male swivel downstream connection (for use with 1/2 ports only):**

H-0A0A*C-C12	5/16 ID coiled	12 (3.7)	9 (2.7)	. . . C-C12
H-0A0A*C-C25	5/16 ID coiled	25 (7.6)	18 (5.5)	. . . C-C25
H-0A0A*C-C50	5/16 ID coiled	50 (15)	36 (11)	. . . C-C50
H-0A0A*C-S12	5/16 ID straight	12 (3.7)	12 (3.7)	. . . C-S12
H-0A0A*C-S25	5/16 ID straight	25 (7.6)	25 (7.6)	. . . C-S25
H-0A0A*C-S50	5/16 ID straight	50 (15)	50 (15)	. . . C-S50

#### REINFORCED URETHANE HOSE

**Includes 3/8 male swivel downstream connection:**

H-0A1B*B-C12	3/8 ID coiled	12 (3.7)	9 (2.7)	. . . E-C12
H-0A1B*B-C25	3/8 ID coiled	25 (7.6)	18 (5.5)	. . . E-C25
H-0A1B*B-C50	3/8 ID coiled	50 (15)	36 (11)	. . . E-C50
H-0A1B*B-S12	3/8 ID straight	12 (3.7)	12 (3.7)	. . . E-S12
H-0A1B*B-S25	3/8 ID straight	25 (7.6)	25 (7.6)	. . . E-S25
H-0A1B*B-S50	3/8 ID straight	50 (15)	50 (15)	. . . E-S50

**Includes 1/4 male swivel downstream connection (for use with 1/2 ports only):**

H-0A1A*C-C12	5/16 ID coiled	12 (3.7)	9 (2.7)	. . . F-C12
H-0A1A*C-C25	5/16 ID coiled	25 (7.6)	18 (5.5)	. . . F-C25
H-0A1A*C-C50	5/16 ID coiled	50 (15)	36 (11)	. . . F-C50
H-0A1A*C-S12	5/16 ID straight	12 (3.7)	12 (3.7)	. . . F-S12
H-0A1A*C-S25	5/16 ID straight	25 (7.6)	25 (7.6)	. . . F-S25
H-0A1A*C-S50	5/16 ID straight	50 (15)	50 (15)	. . . F-S50

\*Upstream connection.

#### UPSTREAM CONNECTION

Direct connect coaxial male (not Q.D.) ..... 0  
Direct connect coaxial Q.D. socket ..... 1  
Manual connect non-coaxial male (not Q.D.) ..... 2  
(Elbow connection must be "A")

† **NOTE:** "P" prefix on lubricator part number indicates that it is supplied without capillary tubing. Instead a probe adapter will be supplied within this assembly.

# LOW FLOW SPL HOSE ASSEMBLIES

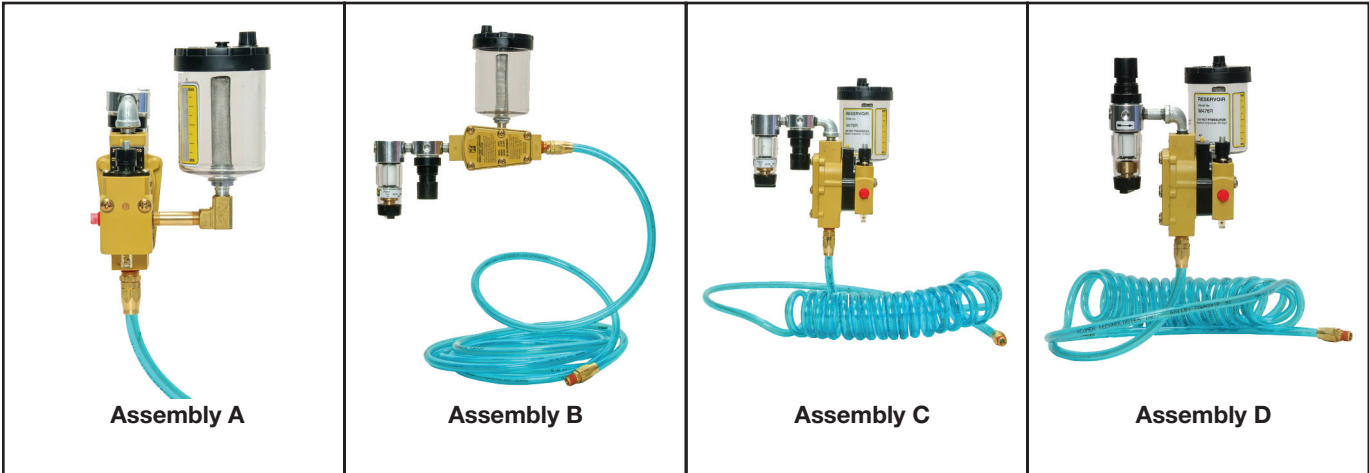

**SERV-OIL** single point lubricators (**SPLs**) have been used for decades to provide economical, precision lubrication to pneumatic devices. They lubricate just the points needing lubrication, not the hose or pipe supplying air to the device.

The low flow **FR-SPL** assembly has been designed to offer a more economical, lower flow **FR-SPL** assembly at the same time supplying the accuracy and reliability that customers have come to rely on with our standard **FR-SPL** assemblies.

The illustrations above are but a small sampling of the available **FR-SPL** combinations using single point lubricators. All those shown are for lubricating **AIRTOOLS** requiring low flow operation only. The injection lubricators used here are not designed for bi-directional flow, and are **NOT** to be used with air cylinders or air motors. Where bi-directional flow is involved the downstream **SPLs** on pages 206-207 would be used.

In the above assemblies the lubricators can be fitted with external oil reservoirs (assemblies A-D) or without the external oil reservoir for applications using central fill oil delivery systems.

The low flow **FR-SPL** assemblies are supplied with a 1/4"NPT inlet port. The outlet port is 1/2"NPT. The downstream hose fitting is supplied with a 1/4"NPT male swivel. Depending on the installation, these

**FR-SPL** low flow assemblies can be ordered in a straight inline design or a 90 degree version allowing these assemblies to be mounted overhead in a workstation.

The coaxial hose assemblies are available with the internal oil capillary tube, including check valve, installed in either straight or coiled blue urethane hose. The standard hose lengths are 12- or 25-feet. Note that the coiled assemblies have a working length less than the overall length. Other hose lengths can be made to the user's exact specifications. Consult the Master Pneumatic Sales Department.

Coiled hose assemblies are typically used in applications where the **SPL** is overhead and hose on the floor needs to be eliminated, or at least minimized. A 90 Degree **FR-SPL** design is recommended to prevent the hose from crimping during operations when the design is called out to be mounted overhead.

## INJECTION LUBRICATION vs. MIST LUBRICATION

- ◆ Increased tool life 2-1/2 – 3x
- ◆ Reduce tool repair cost by 50 – 90%
- ◆ Provide constant lubrication for constant torque
- ◆ Use less oil AND minimize oil discharge in tool exhaust

# HOSE ASSEMBLIES

Straight Hose Assembly



Coiled Hose Assembly



Upstream Connectors



Downstream Connectors



## HOSE for LOW FLOW FR-SPLs ORDERING INFORMATION

Change the letters in the sample model number below to specify the hose assembly you want.

**H-0A 0 A5C - C 12**

**HOSE MATERIAL**

- Urethane ..... 0
- Reinforced Urethane..... 1

**HOSE LENGTH**

- 12 ft (3.7 m); if coiled, 9 ft (2.7 m) working length..... 12
- 25 ft (7.6 m); if coiled, 18 ft (5.5 m) working length..... 25

**HOSE DIAMETER:**

5/16 ID (1/2 upstream connection only)

**UPSTREAM CONNECTION:**

1/2-NPT male (non-coax – upstream barb on capillary tube installed in hose)

**HOSE TYPE**

- Coiled (standard 18" upstream straight tail, 36" downstream straight tail).....C
- For other tail lengths, consult factory*
- Straight.....S

**DOWNSTREAM CONNECTION:**

1/4 male swivel (used with 5/16 ID hose)

# LOW FLOW SPL HOSE ASSEMBLIES

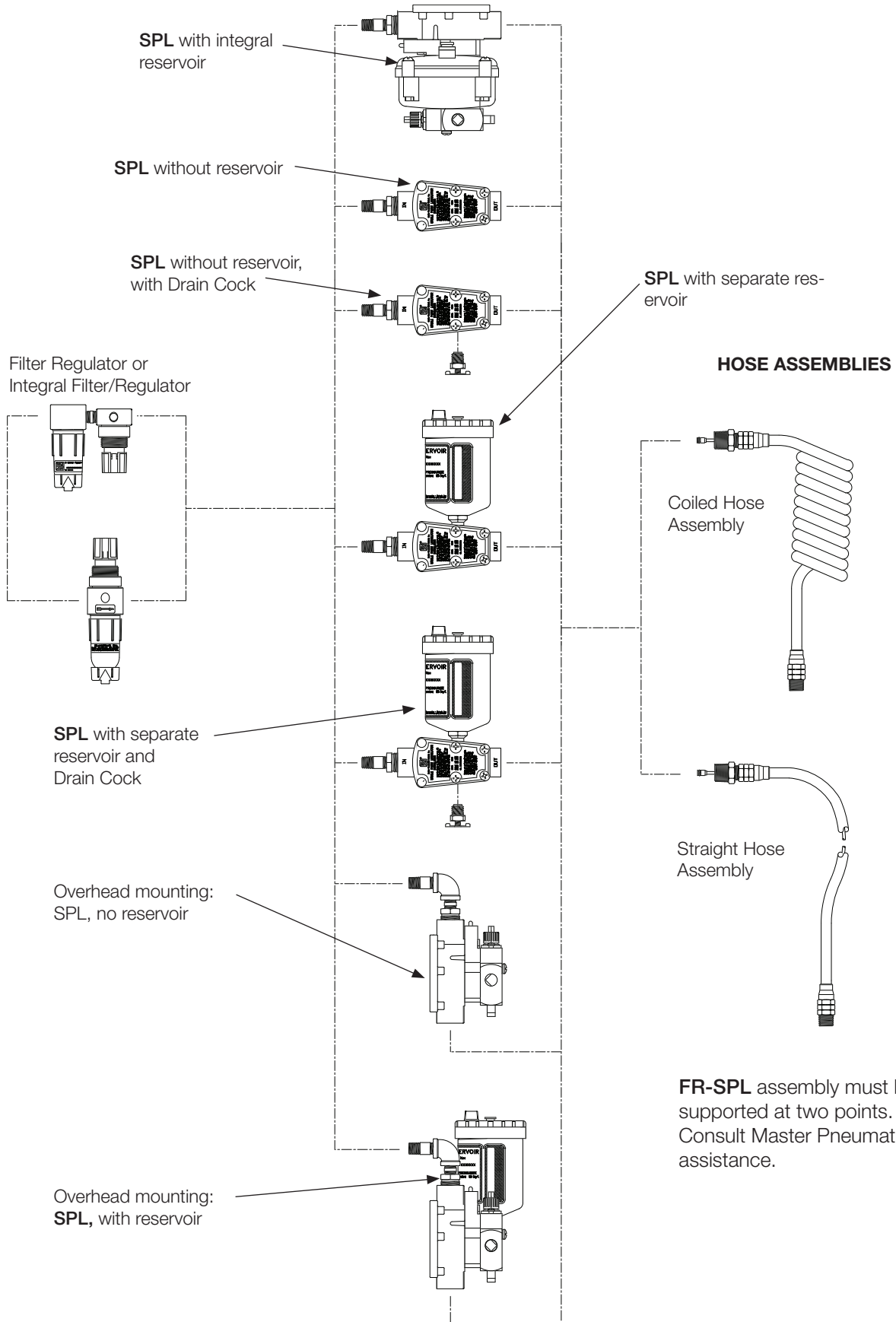

**FR-SPL** assembly must be supported at two points. Consult Master Pneumatic for assistance.



# LOW FLOW AIR TOOL LUBRICATION SYSTEM ORDERING INFORMATION

Change the letters in the sample model number below to specify the assembly you want.

## HB-0 A 0 A 4 A 2 A-C12

### FILTER AND FILTER/REGULATOR OPTIONS

FD50-2.....	B
F50-2.....	C
BFD50-2.....	D
BF50-2.....	E
CFDR55M-2NG.....	F
CFDR55M-2.....	G
CFR55M-2NG.....	H
CFR55M-2.....	J
CFDR56M-2NG.....	K
CFDR56M-2.....	L
CFR56M-2NG.....	M
CFR56M-2.....	N
BCFDR55M-2NG.....	P
BCFDR55M-2.....	Q
BCFR55M-2NG.....	R
BCFR55M-2.....	S
BCFDR56M-2NG.....	T
BCFDR56M-2.....	U
BCFR56M-2NG.....	V
BCFR56M-2.....	W

### REGULATOR

None.....	0
R55M-2.....	1
R55M-2G.....	2
R56M-2.....	3
R56M-2G.....	4

### HOSE ASSEMBLIES

No hose assembly. . . . . B-A00

Assembly Number	Hose Type	Length ft (m)		Code
		Overall	Working	

### URETHANE HOSE

**Includes 1/4 male swivel downstream connection:**

H-0A0A5C-C12	5/16 ID coiled	12 (3.7)	9 (2.7).....	C-C12
H-0A0A5C-C25	5/16 ID coiled	25 (7.6)	18 (5.5)....	C-C25
H-0A0A5C-S12	5/16 ID straight	12 (3.7)	12 (3.7)....	C-S12
H-0A0A5C-S25	5/16 ID straight	25 (7.6)	25 (7.6)....	C-S25

### REINFORCED URETHANE HOSE

**Includes 1/4 male swivel downstream connection:**

H-0A1A5C-C12	5/16 ID coiled	12 (3.7)	9 (2.7).....	F-C12
H-0A1A5C-C25	5/16 ID coiled	25 (7.6)	18 (5.5)....	F-C25
H-0A1A5C-S12	5/16 ID straight	12 (3.7)	12 (3.7)....	F-S12
H-0A1A5C-S25	5/16 ID straight	25 (7.6)	25 (7.6)....	F-S25

### † LUBRICATOR (See pp 204, 206)

**(1/2" port size and 1/2" drop only)**

PA60045.....	C
PA60045, M476R reservoir.....	D
PA60045, M476R reservoir, 1/4" drain cock.....	E
PA60045, 1/4" drain cock.....	F
PA60045, 90° assembly.....	G
PA60045, 90° assembly, M476R reservoir.....	H
PD60045.....	K
PD60045, M476R reservoir.....	L
PD60045, M476R reservoir, 1/4" drain cock.....	M
PD60045, 1/4" drain cock.....	N
PD60045, 90° assembly.....	P
PD60045, 90° assembly, M476R reservoir.....	Q
PA60045BB, double counter.....	S
PA60045BB, M476R reservoir, double counter.....	T
PA60045BB, M476R reservoir, 1/4" drain cock, double counter.....	W
PA60045BB, 1/4" drain cock, double counter.....	X
PA60045BB, 90° assembly, double counter.....	Y
PA60045, 90° assembly, M476R reservoir, double counter.....	Z
PD60045BB, double counter.....	1
PD60045BB, M476R reservoir, double counter.....	2
PD60045BB, M476R reservoir, 1/4" drain cock, double counter.....	3
PD60045BB, 1/4" drain cock, double counter.....	4
PD60045BB, 90° assembly, double counter.....	5
PD60045BB, 90° assembly, M476R reservoir, double counter.....	6

† **NOTE:** "P" prefix on lubricator part number indicates that it is supplied without capillary tubing. Instead a probe adapter will be supplied within this assembly.

Injection  
LUBRICATORS

## TYPICAL MPL APPLICATION

### With 2-Drop Servo-Meters and Integral Oil Reservoir

Diagram A at the right shows a simple circuit using three 2-drop Servo-Meters and an integral oil reservoir. The actuating signal for the Servo-Meters is taken from the downstream side of the operating valve. Each actuation of the valve causes the Servo-Meters to inject oil at three different specific lubrication points. The Servo-Meters can be set to inject as little as 1/5th drop or as much as 2 drops per cycle. No controller is required in this application.

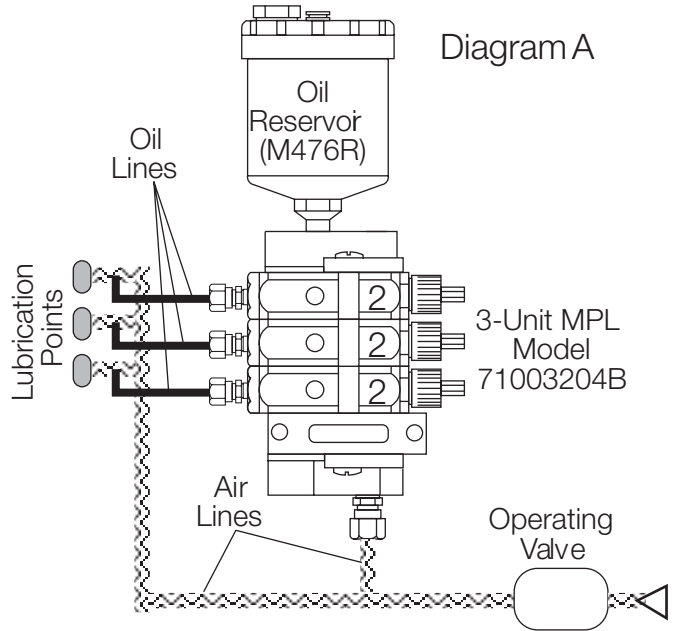

## TYPICAL MPL APPLICATION

### With 1-Drop Servo-Meters, a Pulse Counter, and Remote Oil Reservoir

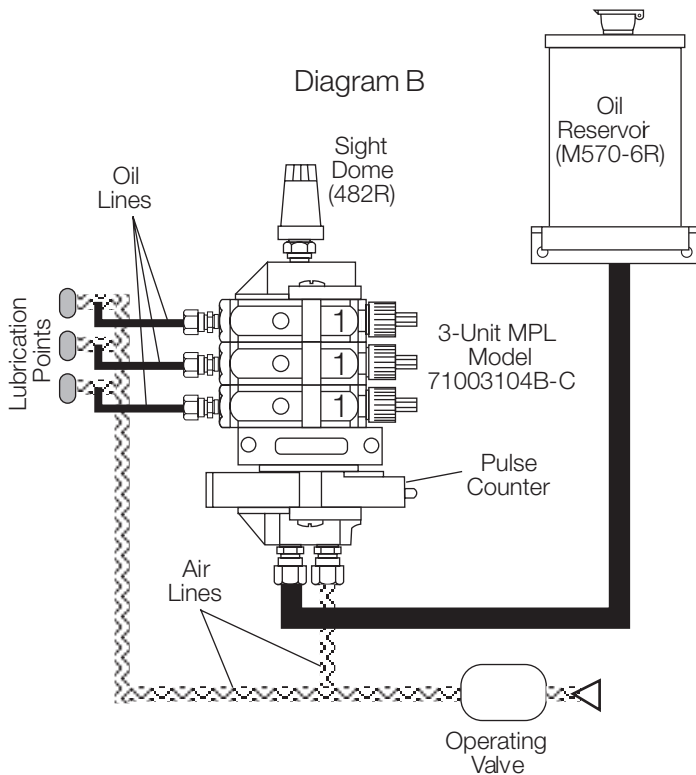

Diagram B at the left shows a circuit using three one-drop Servo-Meters, a pulse counter, and a remote one-quart oil reservoir. The actuating signal for the Servo-Meters is taken from the downstream side of the operating valve. The Servo-Meters can deliver from 1/10th drop to one drop of oil to each of the three different lubrication points. The pulse counter can be set to reduce lubrication by allowing only every 5th or 10th air pulse from the operating valve to actuate the Servo-Meters. For even greater reduction of the lubricating frequency, two pulse counters acting in tandem can be used.

Note the use of a sight dome to vent air from the system.

**An additional Typical Application using a stand-alone frequency generator is shown on the following page.**

## TYPICAL MPL APPLICATION

### With 1/2-Drop Servo-Meters, a Frequency Controller, and Remote Oil Reservoir

In diagram C at the right the **MPL** has 1/2-drop Servo-Meters which can supply from 1/20th drop to 1/2 drop of oil at each actuation. A 10-gallon metal oil reservoir is used. This reservoir could actually supply a number of similar **MPL** lubricating systems. Oil is introduced at the bottom of the assembly, and a standpipe is used to prevent airlock of the Servo-Meters.

A stand-alone frequency controller determines how often the Servo-Meters will inject oil. This can be as often as every second or as infrequent as every five minutes. Air for the controller is from a constant, no-pulse source which the controller will use to create the actuating pulses for the Servo-Meters. The air signal can be introduced at either the top or the bottom of the assembly.

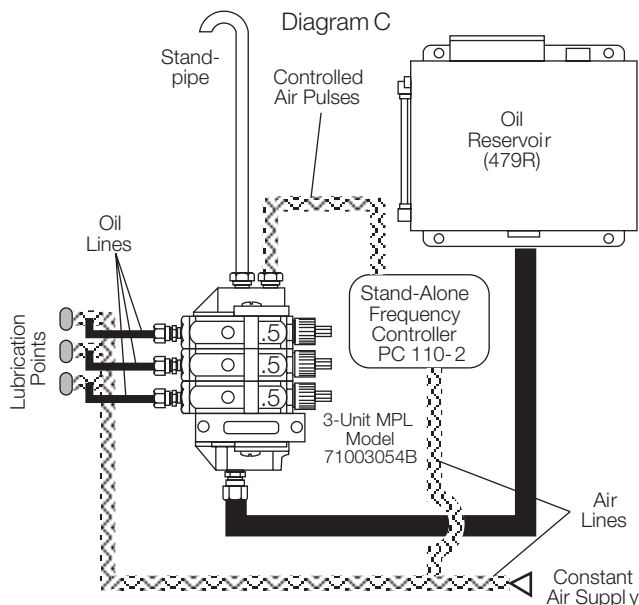

## ASSEMBLY OF MPL SYSTEMS

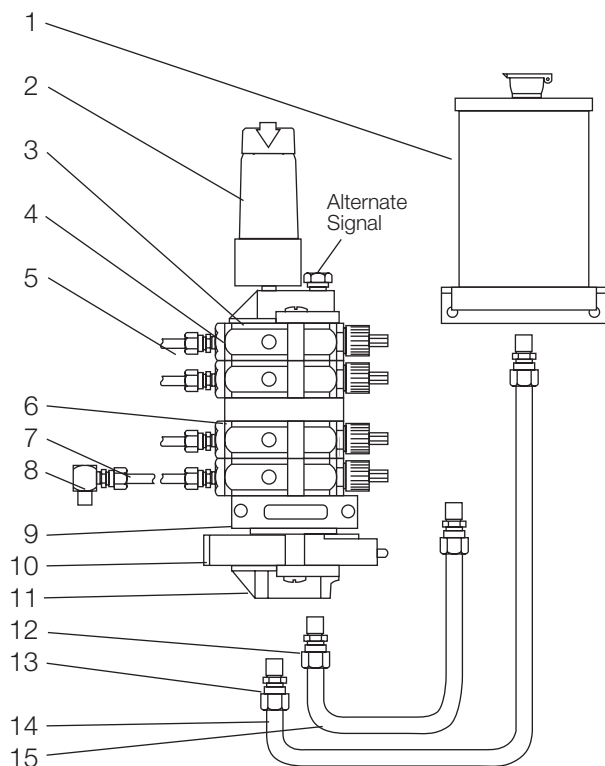

1. Oil reservoir
2. Sight dome for venting air manually and to give visual confirmation of oil in Servo-Meters. Part **482R**.
3. Mounting clamp.
4. Servo-Meter.
5. Prefilled 1/8" nylon oil delivery line. Part **A00942M**.
6. Block plate. Block plate with seals and hardware is kit number **K474-07T**. See page 287.
7. Tube connector. Part **00142W**
8. Ball check valve. One required for inlet to tee before air valves. See page 287 for types and sizes.
9. Mounting plate.
10. Pneumatic pulse counter.
11. Mounting clamp.
12. Tube connector. Part **00184W**.
13. Tube connector. Part **001124W**.
14. Oil supply line; 3/8" nylon tubing. Part **009126-M**. Larger size can be used.
15. Air signal line; 1/4" nylon tubing. Must be from on-off source, usually downstream of operating valve. Part **00984M**. Note: When using a pulse counter, the air signal must first go to the counter, then to the Servo-Meters.

### MPL ASSEMBLY KITS

Servo-Meter Kit (see footnotes)	70001##4B-@
Mounting/Assembly Kit	KA474-10

## – Specify rating:  
 1/2 drop .....05  
 1 drop.....10  
 2 drops.....20

@ – Specify options.  
 See OPTIONS under  
 Ordering Information on  
 following pages.



**MPL Mounting Kit**

# SERV-OIL Multiple-Point Injection Lubricators

## Series 710, 720



Model Shown: 71003104B

Up to 10 Servo-Meters can be assembled to make up a multiple point lubricator (**MPL**). Assembled **MPLs** can be ordered, or they can be assembled by the user employing the Servo-Meter and Assembly/Mounting Kits shown on the facing page. Master Pneumatic recommends that you order factory-assembled **MPLs**. The cost is economical, your installation time is greatly reduced, and you are assured of reliable performance because both the components and the assemblies have been factory-tested.

The frequency of oil injection can be controlled by using one of the pulse counters or frequency controllers detailed on page 200.

Series 710 factory assemblies employ two mounting holes. When a very rigid mounting is needed, order Series 720 which employs heavy-duty mounting plates with four mounting holes.

## SPECIFICATIONS

**Ambient/Media Temperature:**

40° to 125°F (4° to 52°C).

**Controller:** See page 200 for the various types of controllers available.

**Operating Pressure:** 60-150 psig (4.1-10.3 bar).

**Reservoir:** See page 222 for the various types of reservoirs available.

**Servo-Meter:** Brass body; optional Aluminum and Nickel plated housings; acetal end caps. 1-Drop rating; optional 1/2-drop or 2-drop rating. Minimum operating air pressure: 60 psig (4 bar).

**DIMENSIONS** inches (mm)

A	B †	C	D	E †
3.9 (99)	2.5 (64)	1.8 (46)	4.1 (104)	4.3 (109)

† Add 0.9 (23) for each additional Servo-Meter.

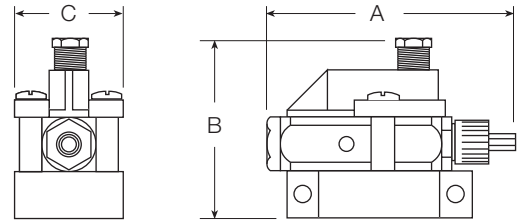

**Without Pulse Counter**

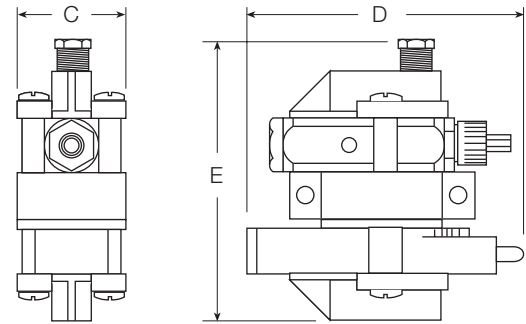

**With Pulse Counter**

**ORDERING INFORMATION**

Change the letters in the sample model number below to specify the **MPL** you want.

**710 01 05 4 B - Y W**

**MPL SERIES**

- Standard MPL assembly..... 710
- MPL assembly with heavy-duty mount..... 720

**NUMBER OF SERVO-METERS**

Specify by numerals  
from 01 to 10

**SERVO-METER RATING**

- Half drop ..... 05
- One drop ..... 10
- Two drops ..... 20

**SERVO-METER HOUSING MATERIAL**

- Brass housing ..... B
- Aluminum housing ..... A
- Nickel plated brass housing, ..... N  
clamp and mounting plate.

**PORT TYPE**

- NPTF Threads ..... Leave Blank
- BSPP threads ..... W

**OPTIONS** (*More than one option can be chosen*)

- None ..... Leave Blank
- Servo-Meter shutoff  
(Non-shutoff is standard) ..... A
- Block plate; indicate position  
from top with \* ..... B\*
- Pulse counter
  - One ..... C
  - Two ..... CC
- Oil End Seals (Buna N standard)
  - EPR ..... E
  - Neoprene ..... N
  - Viton ..... V
- Frequency controller ..... F

# Electronically Controlled SERV-OIL Multiple-Point Lubricators

## Series 7A0



Model Shown: 7A001204B-2110

The electronically controlled multiple-point lubricator has a 3-way solenoid-controlled valve to produce the actuating signals for the Servo-Meters (up to four may be used.). This allows lubrication control to be interfaced with other system electronics, so that the frequency of oil injection is under precise control.

**Servo-Meters.** Up to four can be included in the assembly with ratings of 1/2, 1, or 2 drops. Each Servo-Meter output is adjustable down to just 10 percent of its rating. Because of their modular construction Servo-Meters can be easily added or removed from the assembly.

**Pneumatic Valve.** A solenoid-actuated, 3-way valve provides the air pressure to actuate the Servo-Meters. Inlet pressure must be at least 60 psig (4 bar). Available solenoid voltage options are 24-, 110-, or 220-volts AC and 12-, 24-, or 110-volts DC.

**Oil Supply.** Oil can be supplied from a central reservoir, or an optional integral reservoir. Integral reservoirs are available in 10-ounce (part **M476R**), one-quart (part **M570-6R**), or two-quart (**M570-12R**) capacities.

**Air Filter.** A general-purpose Sentry filter can be included in the assembly, but is not required if external air filtration is adequate, i.e., has at least 40- $\mu$ m filtration.

## SPECIFICATIONS

### Ambient/Media Temperature:

40° to 125°F (4° to 52°C).

**Operating Pressure:** 60-150 psig (4.1-10.3 bar).

**Pneumatic Valve:** Solenoid actuated 3-way. Electrical: 24-, 120-, 220-volts 50/60 Hz; 12-, 24-, 110-volts DC.

**Servo-Meter:** Brass body; optional Aluminum and Nickel plated housings; acetal end caps. 1-Drop rating; optional 1/2-drop or 2-drop rating. Minimum operating air pressure: 60 psig (4 bar). Transparent sight indicator gives visual verification of oil delivery.

## IMPORTANT SERIES 7A0 BENEFITS

Modular design provides Servo-Meters, solenoid valve, and air filter in a complete package with easy add-on capability.

There is no need to purchase additional valves or other components. Simply pipe up an air supply and plug in the **MPL** package.

You have full control by coordinating with your own computer programming. This eliminates costly feast-or-famine lubrication.

### EASY ORDERING FOR SERIES 7A0

Model Number	Servo-Meters	Inlet Port
7A00#054B-11XY	1/2 drop	1/8 NPTF
7A00#054B-21XY	1/2 drop	1/4 NPTF
7A00#104B-11XY	1 drop	1/8 NPTF
7A00#104B-21XY	1 drop	1/4 NPTF
7A00#204B-11XY	2 drops	1/8 NPTF
7A00#204B-21XY	2 drops	1/4 NPTF

# – Insert quantity of Servo-Meters (1 to 4).  
 X – Insert voltage number (see Ordering Information below).  
 Y – Insert filter number (see Ordering Information below).

### DIMENSIONS inches (mm)

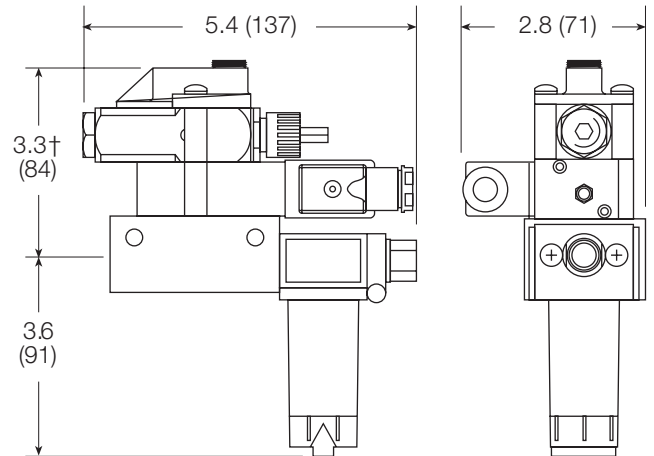

† Add 0.9 (23) for each additional Servo-Meter

### ORDERING INFORMATION

Change the letters in the sample model number below to specify the **MPL** you want.

**7A0 01 05 4 B – 1 1 1 0 W**

**MPL SERIES**

**NUMBER OF SERVO-METERS**  
 Specify by numerals  
 from 01 to 04

**SERVO-METER RATING**  
 Half drop ..... 05  
 One drop ..... 10  
 Two drops ..... 20

**SERVO-METER HOUSING MATERIAL**  
 Brass housing ..... B  
 Aluminum housing ..... A  
 Nickel plated brass housing, ..... N  
 clamp and mounting plate.

**INLET PORT SIZE**  
 1/8 NPTF ..... 1  
 1/4 NPTF ..... 2

**DIN 4360 Form B Option** ..... 1

**PORT TYPE**

NPTF Threads ..... Leave Blank  
 BSPP threads ..... W

**FILTER**

Standard Sentry filter ..... 0  
 No filter; female side port ..... 1

**VOLTAGE**

120 volts, 50/60 Hz ..... 1  
 24 volts, DC ..... 2  
 24 volts, 50/60 Hz ..... 3  
 220 volts, 50/60 Hz ..... 4  
 12 volts, DC ..... 5  
 110 volts, DC ..... 6

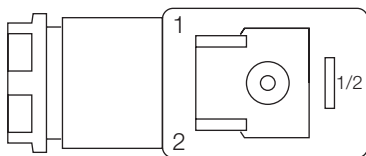

Normal Polarity:  
 1 = (+) positive, high  
 2 = (-) negative, neutral  
 1/2 = chassis ground

**NOTE:** Optional automotive standard to mini plug is available. Consult Master Pneumatic.

# SERV-OIL Automation Pacs

# Series 730

Model Shown: 73010104B-CC

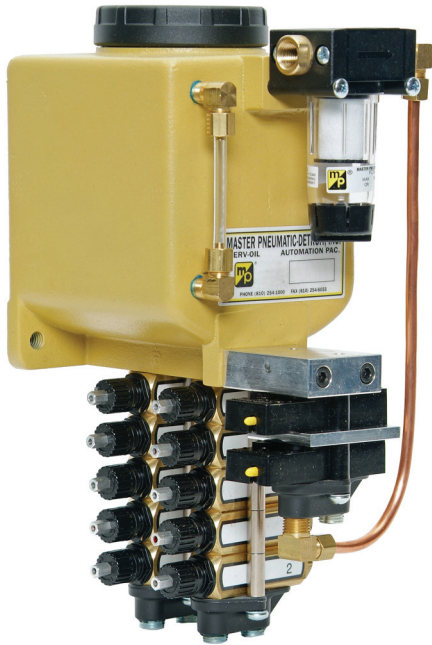

**Automation Pac with Double-Counter Controller  
For Use with Pulse Air Inlet Source**

Model Shown: 73010104B-F

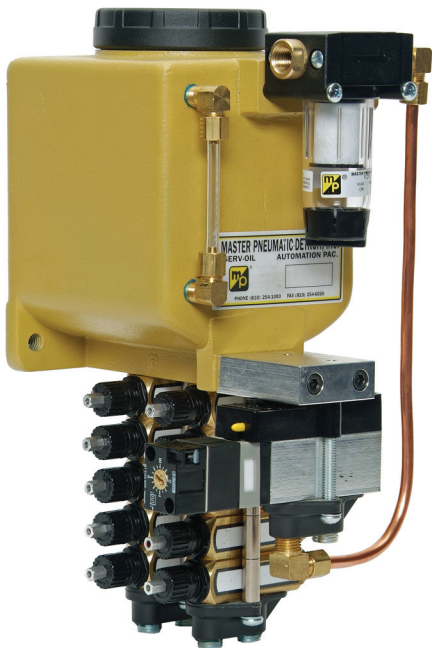

**Automation Pac with Frequency Controller  
For Use with Constant Air Inlet Source**

A **SERV-OIL** Automation Pac is a self-contained assembly of oil reservoir, up to 20 Servo-Meters, and a controller. It is supplied ready for installation in a pneumatic circuit, with only ball checks, fittings, and tubing being required. The Automation Pac will provide precision lubrication for up to 20 points on valves, cylinders, fixtures, automation equipment, and machine tools using pneumatic components.

**Oil Reservoir.** The Automation Pac oil reservoir is made of cast aluminum, and has a capacity of 1/2 gallon (1.9 liters). It has a built-in oil strainer, a transparent sight tube, a quick-fill cap, and a screw-on lid.

If the Automation Pac is located where the oil level cannot easily be determined visually, electrical oil-level switches are available. There are both high-level and low-level switches. They can be connected to a remote electrical control for automatic filling of the reservoir.

**Controllers:** (See page 200.) Double pulse counters, with or without a frequency generator, can be used to control the frequency of oil injection. These can be integrated into the assembly, or be in the form of stand-alone controllers. A stand-alone controller can be employed to control the injection frequency of several Automation Pacs.

In either case actuation pulses from the system control valve initiate the oil injection function. The controller then is set so the actual oil injection could be every cycle, or every 5, 10, 25, 50, or 100 cycles of the control valve.

Both types of controller are supplied with a 0.3- $\mu$ m coalescing filter for clean, long-life operation. The coalescing filter should be preceded by 5- $\mu$ m filtration to prolong the life of the coalescing element.

## SPECIFICATIONS

**Ambient/Media Temperature:**

40° to 175°F (4° to 79°C).

**Reservoir:** Aluminum; 0.5 gallon (1.9 liters) capacity.

**Seals:** Nitrile.

**Servo-Meter:** Brass body; optional Aluminum and Nickle Plated brass; acetal end caps.

**Servo-Meter Operating Pressure:**

60-150 psig (4.1-10.3 bar).



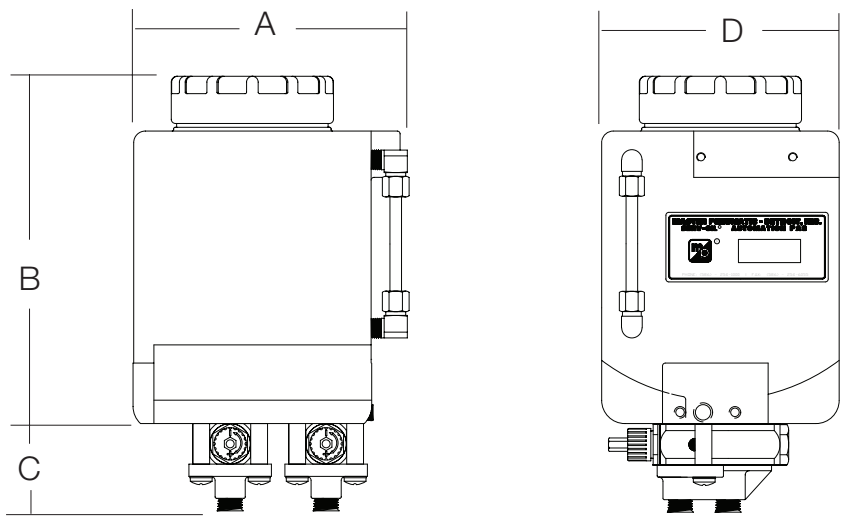

**DIMENSIONS** inches (mm)

A	B	C †	D	Weight lb (kg)
5.1 (130)	7.6 (193)	1.8 (46)	5.1 (130)	6.6 (3.0)

† Dimension for single Servo-Meter. For each additional Servo-Meter add 0.9 (23).

**ORDERING INFORMATION**

Change the letters in the sample model number below to specify the Automation Pac you want.

**730 01 05 4 B -Y W**

**AUTOMATION PAC SERIES**

**NUMBER OF SERVO-METERS**

Specify by numerals  
from 01 to 20

**SERVO-METER RATING**

- Half drop ..... 05
- One drop ..... 10
- Two drops ..... 20

**SERVO-METER HOUSING MATERIAL**

- Brass housing ..... B
- Aluminum housing ..... A
- Nickel plated brass housing ..... N  
and clamp.

**PORT TYPE**

- NPTF Threads ..... Leave Blank
- BSPF threads ..... W

**OPTIONS** (More than one option can be chosen)

- None ..... Leave Blank
- Servo-Meter shutoff  
(Non-shutoff is standard) ..... A
- Block plate ..... B  
(Consult Master Pneumatic)
- Two pulse counters ..... CC
- Oil-end seals for Servo-Meter  
(Buna N standard)
- EPR ..... E
- Viton ..... V
- Frequency controller ..... F
- Oil-level switches:
- Low-level only ..... G
- High-level and low-level ..... GG

# Liquid Dispensers

## Series 740, 770



Model Shown: 74004204B-ALV

The Series 740 liquid dispenser employs Servo-Meters to send precise amounts of liquid through nozzles for a distance up to 10 inches (250 mm). It is primarily used where liquid without entrained air is wanted, and a precisely controlled jet is not required. Up to 10 Servo-Meters can be used in a single assembly. A pressure of at least 60 psig (4 bar) is required for actuation.

1/8-Inch O.D. nylon tubing carries the oil from a Servo-Meter to a nozzle [5/64" (2-mm) orifice] located near the delivery point.

**Install a liquid-only dispenser so that the Servo-Meters are vertical and the outlets are at the top.** This helps to eliminate air from the system. The nozzles need to be secured in place with a clamp or similar means.

Series 740 factory assemblies employ two mounting holes. When a very rigid mounting is needed, order Series 770 which employs heavy-duty mounting plates with four mounting holes.

Liquid dispenser assemblies can be ordered, or they can be assembled by the user employing the Servo-Meter and Assembly/Mounting Kits shown on the facing page.

***Master Pneumatic recommends that you order factory-assembled dispensers. The cost is economical, your installation time is greatly reduced, and you are assured of reliable performance because both the components and the assemblies will have been factory-tested.***

### SPECIFICATIONS

**Ambient/Media Temperature:**

40° to 125°F (4° to 52°C).

**Inlet Pressure:** 60 to 120 psig (4 to 8 bar).

**On/Off Control:** Manual.

Servo-Meter Body: Brass; optional Aluminum and Nickel plated brass; zinc end plates.

**Servo-Meter Seals:**

Nitrile on air end; viton on oil end.

**DIMENSIONS** inches (mm)

A	B †	C
3.9 (99)	2.5 (64)	1.8 (46)

† Add 0.9 (23) for each additional Servo-Meter.

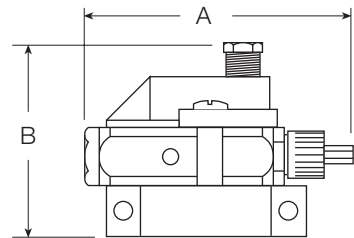
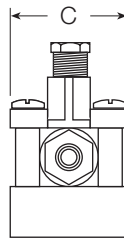

**LIQUID DISPENSER ASSEMBLY KITS**

Servo-Meter Kit (see footnotes)	70001##4B-@LV
Mounting/Assembly Kit	KA474-10

## – Specify rating:                      @ – Remove if non-shutoff  
 1/2 drop.... 05                              A.....Shutoff  
 1 drop.... 10  
 2 drops.... 20

**Mounting/Assembly Kit**

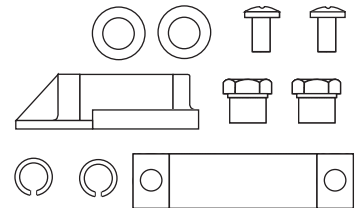

**ORDERING INFORMATION**

Change the letters in the sample model number below to specify the Liquid Dispenser you want.

**740 01 05 4 B - Y L V W**

**LIQUID EJECTOR SERIES**

- Assembly with standard mount ..... 740
- Assembly with heavy-duty mount..... 770

**NUMBER OF SERVO-METERS**

Specify by numerals from 01 to 10

**SERVO-METER RATING**

- Half drop ..... 05
- One drop..... 10
- Two drops ..... 20

**SERVO-METER HOUSING MATERIAL**

- Brass housing ..... B
- Aluminum housing ..... A
- Nickel plated brass housing, ..... N
- clamp and mounting plate.

**PORT TYPE**

- NPTF Threads ..... Leave Blank
- BSPP threads ..... W

**OPTION**

- Oil end seals for Servo-Meter
- Viton ..... V
- EPR ..... Leave Blank
- (Add E using other option Location)

**OPTIONS (More than one option can be chosen)**

- None ..... Leave Blank
- Servo-Meter shutoff (Non-shutoff is standard) ..... A
- Pulse counters
- One..... C
- Two..... CC
- Oil End Seals for Servo-Meter
- EPR ..... E
- Frequency controller ..... F

# SERV-OIL JETMASTER Liquid Dispenser Propels Conical Air-Liquid Jets

**Series 750,  
760**

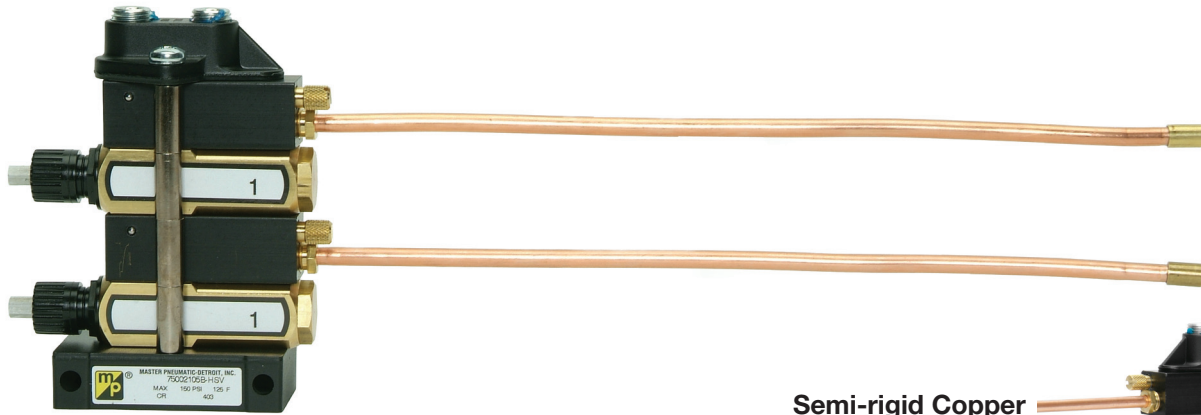

**Model Shown:** 75002105B-HSV

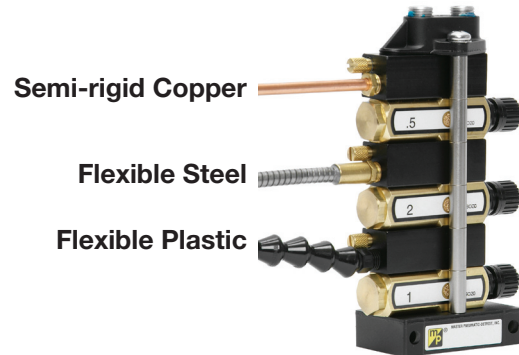

The Serv-Oil Jetmaster Liquid Dispenser is used for the controlled application of many types of liquids. Light, chemically non-aggressive spindle lubricating oil, however, is the most commonly used liquid\*.

The Jetmaster employs a Servo-Meter and a nozzle to propel a conical air-liquid jet up to 10 inches (25 cm) with pinpoint accuracy, and with no drip or overspray. The amount of liquid and the amount of air in the jet are independently adjustable. The Jetmaster is actuated by an air pulse (usually from a valve), and controllers are available to determine the frequency with which a jet is propelled. Viton seals are standard.

### Multiple Jetmaster Dispensers

Assemblies may be ordered with up to five Servo-Meters and five nozzles. All can be actuated simultaneously by a single air signal of 60 psig (4 bar).

To increase the amount of liquid in a single jet, multiple Servo-Meters can feed through a single nozzle. Consult Master Pneumatic for further information.

### Nozzles

Twelve-inch nozzles are standard, but other lengths can be special ordered. The standard copper tube nozzles can be bent in any direction to dispense liquid at the point of need. Teflon tubing running through the nozzle carries the liquid to the nozzle end where it is propelled from the tubing by the air jet passing around it. An air metering adjustment screw is provided for each nozzle.

### JETMASTER NOZZLE ASSEMBLIES

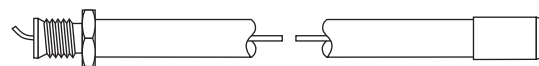

**Semi-rigid Copper** (Standard - suffix H)

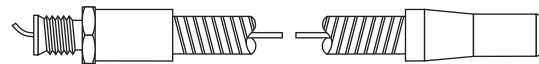

**Flexible Steel** (Optional - suffix M)

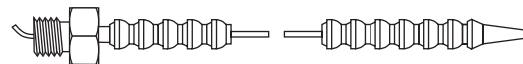

**Flexible Plastic** (Optional - suffix K)

\*Contact M/P for fluid compatibility.

**DIMENSIONS** inches (mm)

A	B †	C
3.5 (89)	3.4 (86)	1.8 (46)

† Add 0.9 (23) for each additional Servo-Meter.

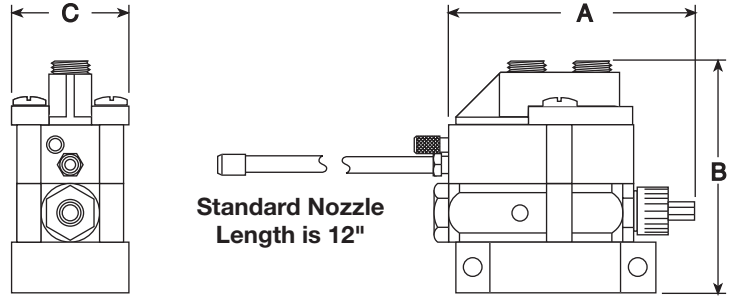

**LIQUID DISPENSER ASSEMBLY KITS**

Servo-Meter Kit (see footnotes)	70001##4B-@LV
Mounting/Assembly Kit	KA474-10

## – Specify rating:                      @ – Remove if non-shutoff  
 1/2 drop .... 05                              A.....Shutoff  
 1 drop .... 10  
 2 drops .... 20

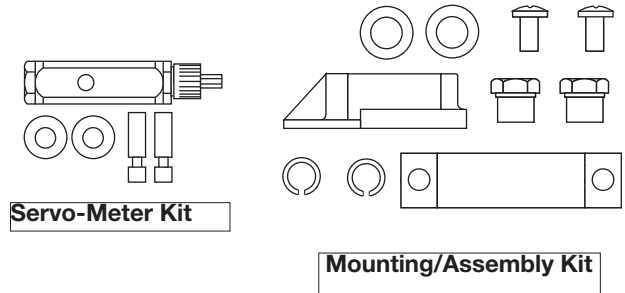

**ORDERING INFORMATION**

Change the letters in the sample model number below to specify the Liquid Dispenser you want.

**750 01 05 5 B - Y H 00 S V W**

**JETMASTER SERIES**

Standard Jetmaster ..... 750  
 Jetmaster with heavy-duty mount ..... 760

**NUMBER OF SERVO-METERS**

Specify by numerals from 01 to 05

**SERVO-METER RATING**

Half drop ..... 05  
 One drop ..... 10  
 Two drops ..... 20

**SERVO-METER HOUSING MATERIAL**

Brass housing ..... B  
 Aluminum housing ..... A  
 Nickel plated brass housing, ..... N  
 clamp and mounting plate.

**PORT TYPE**

NPTF Threads ..... Leave Blank  
 BSPP threads ..... W

**OPTION**

Oil end seals for Servo-Meter  
 Viton ..... V  
 EPR ..... Leave Blank  
 (Add E using other option Location)

**NOZZLE LENGTH**

Length of copper nozzle if other than 12"

**NOZZLE TYPE**

Standard 12" flexible  
 copper nozzle ..... H  
 12" flexible  
 plastic nozzle ..... K  
 12" flexible  
 steel nozzle ..... M

**OPTIONS** (More than one option can be chosen)

None ..... Leave Blank  
 Servo-Meter shutoff  
 (Non-shutoff is standard) ..... A  
 Pulse counters  
 One ..... C  
 Two ..... CC  
 Oil End Seals for Servo-Meter  
 EPR ..... E  
 Frequency controller ..... F

**SCORPION and LIQUID DISPENSERS**

# SCORPION

Liquid dispensers are used where precise control of the delivery of liquids such as water or coolant is required. Specially adapted positive-displacement Servo-Meters inject precisely controlled amounts of liquid at designated intervals.

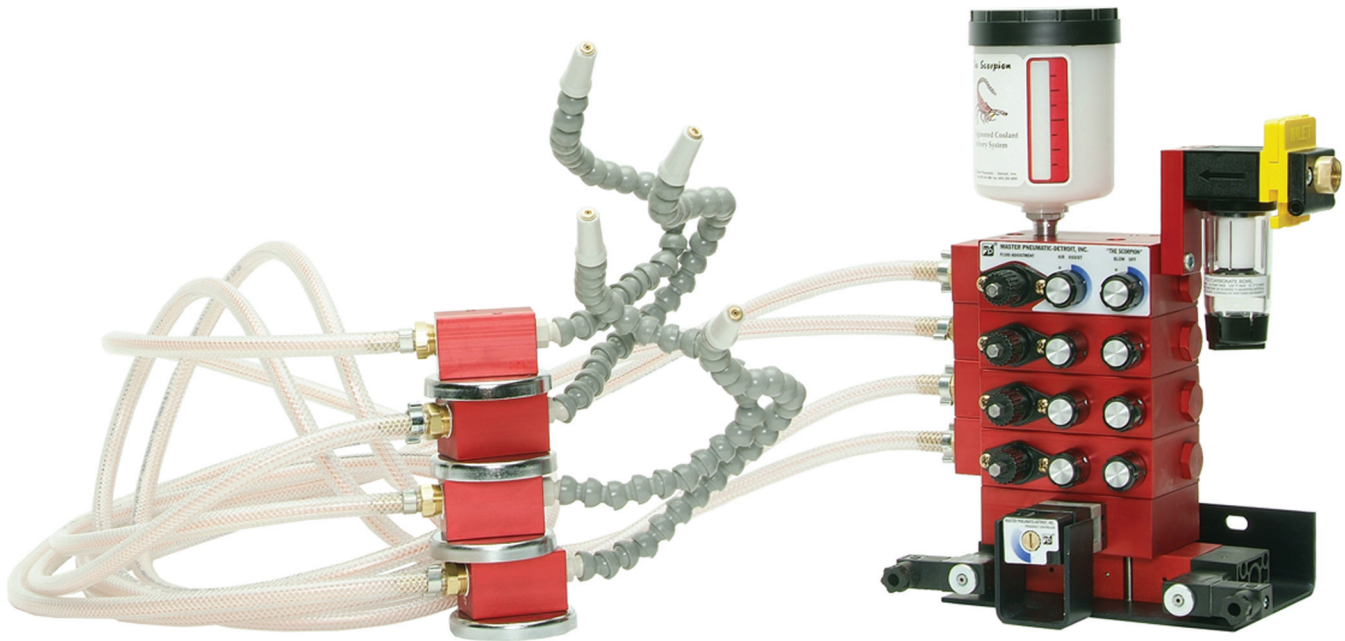

The Scorpion is a compact, pneumatically controlled system for the delivery of coolant to cutting edges in precisely controlled amounts and frequency. It is a cost-effective solution to the waste management problems created by flood coolants.

When used in machining and grinding operations the Scorpion directs a precise amount of coolant and air directly onto the tool's cutting edges.

An optional blowoff feature programs compressed air to remove chips, cool the workpiece, and clean the area between applications of coolant. Injection of coolant and the air blowoff feature operate independently for flexible control.

On/off control is either pneumatic or electric, the latter allowing the Scorpion to be interfaced with external electronic controls.

# SCORPION Features

**Coolant Reservoir:** 10-ounce capacity standard; optional capacities up to 2 quarts. Remote 5-gallon reservoir also available. See PneuCool Coolant Concentrate (page 286). For use with other liquids, consult Master Pneumatic.

**Fluid Adjustment:** Sets the amount of coolant delivered at each output pulse.

**Output Line:** Coaxial flexible line conducts coolant and air from control assembly to magnetic transfer junction.

**Magnetic Mounting Block:** Provides strong attachment to iron or steel surface.

**Output Delivery Line:** Coaxial line delivers coolant and air to the cutting interface. Line is flexible for easy and accurate positioning. Available as segmented flexible plastic, or semi-rigid copper tubing. Scorpion units are available with one to four output lines.

**Pneumatic Valve:** Used with Scorpion units with optional blowoff control. Provides on/off and blowoff control, and permits interfacing with external controls.

**Frequency Control:** Adjusts frequency of output pulses, i.e., coolant injection.

**Air Filter:** 5-Micron filter element assures essential clean air to the Scorpion unit.

**Lockout Valve:** Built in valve provides manual on/off control. During lockout of supply pressure, the valve allows exhausting of compressed air in the Scorpion.

**Air Inlet:** For pressurized air from 60 to 120 psig (4 to 8 bar).

**Blowoff Adjustment:** Optional blowoff feature allows compressed air to be programmed to remove chips, cool the workpiece, and clean the area between applications of coolant.

**Air Assist Adjustment:** Adjusts the amount of air in the coolant/air output mixture. Aids in directing the coolant flow, and helps to keep the work area clean.

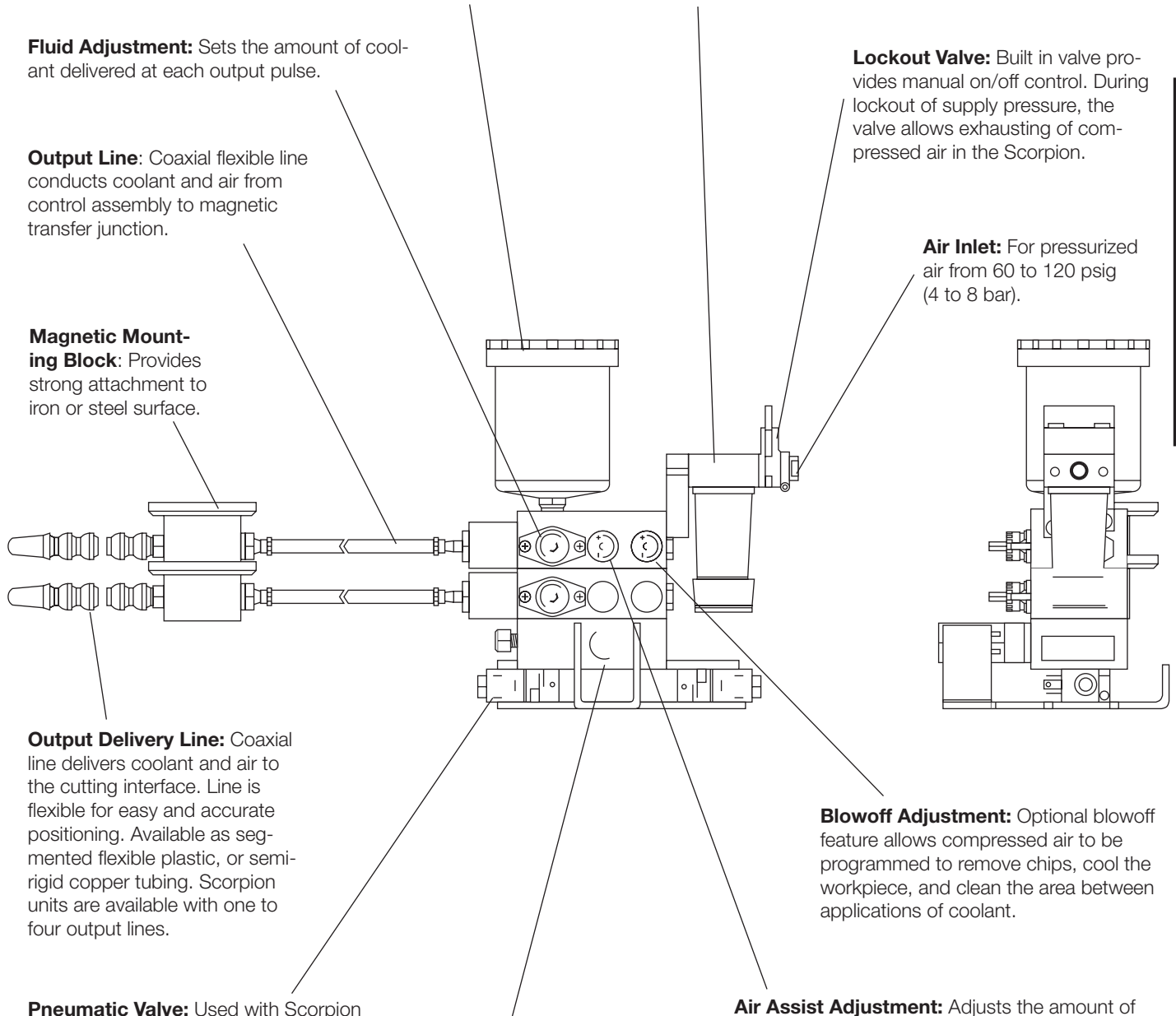

**SCORPION and LIQUID DISPENSERS**

# SCORPION

## Solenoid or Pneumatic Actuation

## Series 800, 830, 850

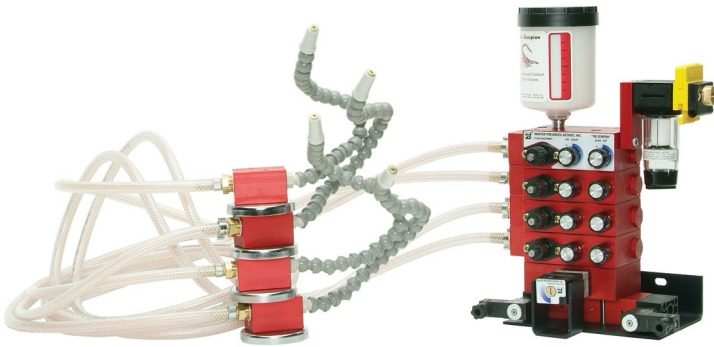

Model Shown: 8504

- ◆ Servo-Meter injector. 1-Drop capacity; optional 2-drop and 1/2-drop capacities.
- ◆ Up to four injectors and nozzles can be used.
- ◆ Patented blowoff feature.
- ◆ Snaplock® coolant dispensing nozzle. Optional copper nozzles.
- ◆ Braided PVC hose.
- ◆ Magnetic nozzle base.
- ◆ 10-Ounce capacity coolant reservoir.
- ◆ NPTF port threads; optional BSPP threads.

### SPECIFICATIONS

**Ambient/Media Temperature:**

40° to 125°F (4° to 52°C).

**Body Blocks:** Anodized aluminum.

**Hose:** 6-Ft braided PVC; longer or shorter hose optional in 1-foot increments.

**Injector:** 1-Drop-rated Servo-Meter; 0 to 0.027 ml per pulse. Optional 2-drop-rated Servo-Meter; 0 to 0.060 ml per pulse. Injection frequency up to 100 pulses per minute.

**Inlet Port:**

1/4 NPTF; optional 1/8 NPTF and BSPP threads.

**Inlet Pressure:** 60 to 120 psig (4 to 8 bar).

**Nozzle:** Snaplock® with 12-inch flexible segmented plastic. Optional 18-inch or 24-inch lengths. Optional copper nozzles.

**On/Off Control:** Manual. Optional solenoid control with or without blowoff feature.

**Reservoir:** Integral semi-clear polypropylene with 10-ounce (300 ml) capacity. Optional 1-quart and 2-quart capacities. Also no-reservoir option for use with remote reservoir.

**Seals:** Air, nitrile; oil, Viton.

**Solenoid Voltages:** (With optional solenoid)

110 or 220 volts, 50/60 Hz; 24 volts D.C.

### BASIC SYSTEMS

Three basic Scorpion systems are described below. They will satisfy the requirements of most coolant applications, and can be ordered by the 4-digit numbers given in the descriptions. However, to order a system with additional options see Ordering Information on the facing page.

**System 8001:** Single nozzle with manual on/off control. Can be ordered with 2, 3, or 4 nozzles by changing the last digit to the number of nozzles wanted. For example, a 3-nozzle system would be ordered by number 8003.

**System 8301:** Single nozzle with solenoid on/off control. 110 volts, 50/60 Hz. Can be ordered with 2, 3, or 4 nozzles by changing the last digit to the number of nozzles wanted. For example, a 4-nozzle system would be ordered by number 8304.

**System 8501:** Single nozzle with solenoid on/off control with blowoff feature. 110 volts, 50/60 Hz. Can be ordered with 2, 3, or 4 nozzles by changing the last digit to the number of nozzles wanted. For example, a 2-nozzle system would be ordered by number 8502.



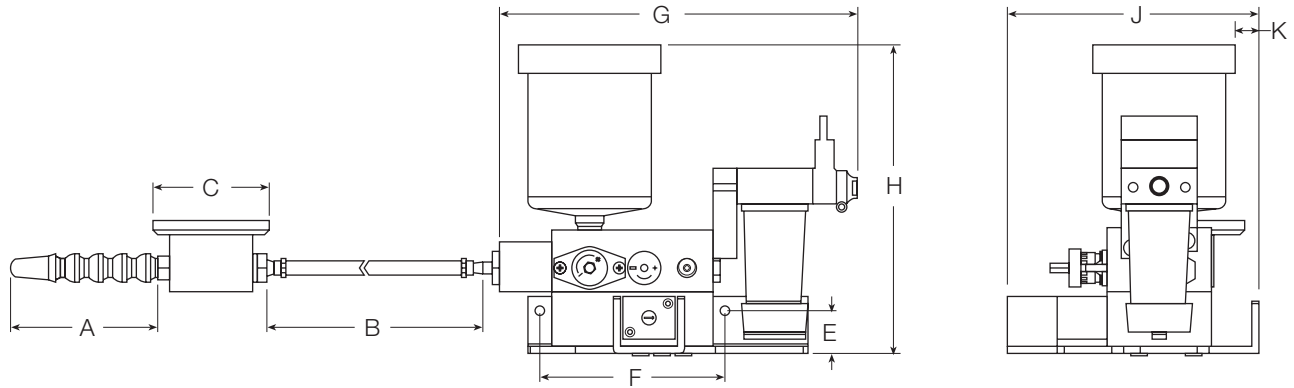

**DIMENSIONS** inches (mm)

Dimension	Manual On/Off	Solenoid On/Off	Solenoid On/Off Plus Blowoff	Add for Each Additional Nozzle Assembly
A	12 (305) Std.	12 (305) Std.	12 (305) Std.	—
B	72 (1829) Std.	72 (1829) Std.	72 (1829) Std.	—
C	2.62 (67)	2.62 (67)	2.62 (66.7)	—
E	0.9 (23)	0.9 (23)	0.9 (23)	—
F	4.4 (112)	4.4 (112)	4.4 (112)	—
G	8.3 (211)	8.3 (211)	8.3 (211)	—
H	7.4 (188)	9.1 (231)	9.1 (231)	1.3 (33)
J	5.9 (150)	5.9 (150)	5.9 (150)	—
K	0.5 (13)	0.5 (13)	0.5 (13)	—

**SCORPION and LIQUID DISPENSERS**

### ORDERING INFORMATION

Change the letters in the sample model number below to specify the Scorpion assembly you want.

**80 0 A 1 1 0 0 1 T 06 K A 1**

#### ON/OFF ACTUATION

- Manual ..... 80
- Solenoid ..... 83
- Solenoid with blowoff ..... 85

#### SOLENOID VOLTAGE

- No solenoid (Series 80 only) ..... 0
- 110 volts, 50/60 Hz (Series 83, 85) ..... C
- 220 volts, 50/60 Hz (Series 83, 85) ..... F
- 24 volts, D.C. (Series 83, 85) ..... E

#### BRACKETS

- With standard bottom bracket only ..... A
- With standard bottom bracket plus extended back bracket ..... D

#### NUMBER OF NOZZLES

Specify number from 1 to 4.

#### INJECTOR RATING

- 1 Drop (Standard) ..... 1
- 2 Drops ..... 2
- 1/2 drop ..... 5

#### RESERVOIR:

- 10-Ounce capacity ..... 0
- No reservoir ..... 1
- 1 Qt with mounting plate ..... 2
- 2 Qt with mounting plate ..... 3

#### NOZZLE TIP

- Standard conical nozzle ..... 1
- Fantip nozzle ..... 2

#### PLASTIC NOZZLE LENGTH

- 12 inches (305 mm) ..... A
- 18 inches (457 mm) ..... B
- 24 inches (610 mm) ..... C

#### NOZZLE TYPE

- Copper ..... H
- Snaplock® ..... K

#### HOSE LENGTH

- Standard PVC (6 feet) ..... 06
- Specify desired length (in feet) with two digits. For example, 08 for 8 feet, 12 for 12 feet ..... \*\*

#### INLET PORT with SENTRY FILTER

- 1/8 NPTF ..... 1
- 1/4 NPTF ..... 2
- 1/8 BSPP ..... A
- 1/4 BSPP ..... B

#### NOZZLE BASE ("C" in drawing above)

- Magnetic ..... 0
- No base ..... 1

# SCORPION Jr. Pneumatic Actuation

Series 890



Model Shown: 8901

- ◆ Operated by pneumatic pulse.
- ◆ Up to four injectors and nozzles can be used.
- ◆ Servo-Meter injector. 1-Drop capacity; optional 2-drop and 1/2-drop capacities.
- ◆ Snaplock® coolant dispensing nozzle. Optional copper nozzles.
- ◆ Optional magnetic nozzle base.
- ◆ Optional 10-ounce capacity coolant reservoir.
- ◆ NPTF port threads; optional BSPP threads.

## SPECIFICATIONS

**Ambient/Media Temperature:**

40° to 125°F (4° to 52°C).

**Body Blocks:** Anodized aluminum.

**Hose:** Optional 6 feet long braided PVC. Longer or shorter hose in 1-foot increments.

**Injector:** 1-Drop-rated Servo-Meter; 0 to 0.027 ml per pulse. Optional 2-drop-rated Servo-Meter; 0 to 0.060 ml per pulse. Up to four injectors can be used. Injection frequency up to 100 pulses per minute.

**Inlet Port:**

1/8 NPTF; optional 1/4 NPTF. Optional BSPP threads.

**Inlet Pressure:** 60 to 120 psig (4 to 8 bar).

**Nozzle:** Snaplock® with 12-inch flexible segmented plastic. Optional 18-inch or 24-inch lengths. Optional copper nozzles and fan tips.

**On/Off Control:** Manual.

**Reservoir:** Optional integral clear plastic with 10-ounce (300 ml) capacity.

**Seals:** Air, nitrile; oil, Viton.

## BASIC SYSTEMS

Four basic Scorpion Jr. systems are described below. They will satisfy the requirements of many coolant applications, and can simply be ordered by the 4-digit model numbers given in the descriptions. However, to order a system with additional options see Ordering Information on the facing page.

**Model 8901:** One-injector system.

**Model 8902:** Two-injector system.

**Model 8903:** Three-injector system.

**Model 8904:** Four-injector system

Each of the above includes:

- 1/8 NPTF inlet port
- One-drop injectors
- 12-Inch Snaplock® nozzle
- No filter

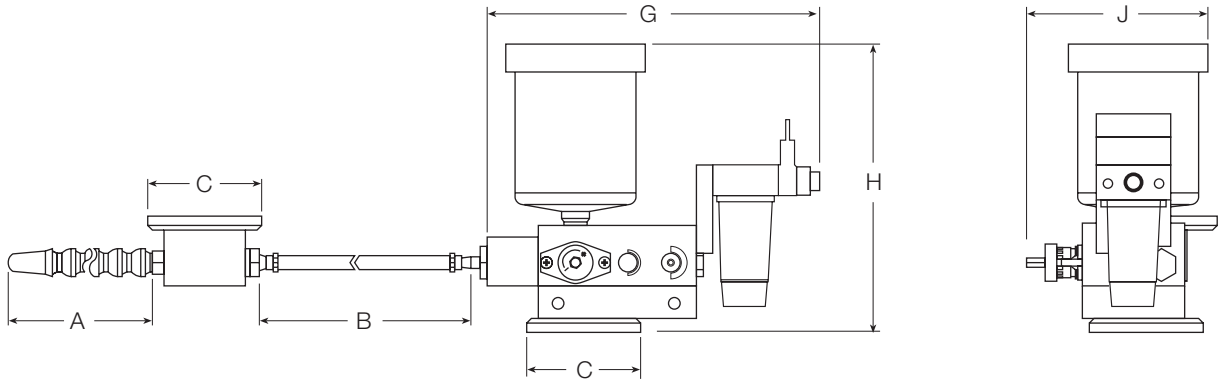

**DIMENSIONS** inches (mm)

Dimension		Add for Each Additional Nozzle Assembly
A	12 (305) Std.	—
B	72 (1830) Std.	—
C	2.6 (66)	—
G	5.3 (135)	—
H	7.2 (183)	1.3 (33)
J	4.3 (109)	—

**ORDERING INFORMATION**

Change the letters in the sample model number below to specify the Scorpion Jr. assembly you want.

**8900 1 1 0 0 1 A 00 K B 1**

**NUMBER OF INJECTORS/NOZZLES**

Specify number from 1 to 4.

**INJECTOR RATING**

- 1 Drop (standard)..... 1
- 2 Drops ..... 2
- 1/2 Drop..... 5

**RESERVOIR**

- 10-Ounce capacity ..... 0
- None ..... 1
- 10-Ounce capacity (no coolant) ..... 4

**MOUNTING BLOCK BASE** (See C in dimensional drawing above.)

- Magnetic ..... 0
- No base ..... 1

**INLET PORT and FILTER**

- 1/8 NPTF (with Sentry filter) ..... 1
- 1/4 NPTF (with Sentry filter) ..... 2
- 1/8 NPTF (without filter) ..... 0
- 1/8 BSPP (with Sentry filter)..... A
- 1/4 BSPP (with Sentry filter)..... B
- 1/8 BSPP (without filter)..... C
- 1/4 BSPP (without filter)..... D

**NOZZLE**

- Standard conical tip..... 1
- Fan tip..... 2

**NOZZLE LENGTH**

- 12 inches (305 mm)..... A
- 18 inches (457 mm)..... B
- 24 inches (610 mm)..... C
- 36 inches (914 mm)..... D

**NOZZLE TYPE**

- Copper..... H
- Snaplock® ..... K

**HOSE LENGTH**

- None ..... 00
- 6 Feet (1.8 m) with base C in dimensional drawing above ..... 06
- Specify desired length (in feet) with two digits. For example, 08 for 8 feet, 12 for 12 feet ..... \*\*

**HOSE TYPE**

- None ..... A
- Braided PVC hose ..... T

# VIPER Chain Lubricators Electro-Pneumatic Actuation

## Series 870



Model Shown: 8703

The **VIPER** is an engineered system used to deliver lubricant for a specific amount of time and at specific intervals. The most common application is lubricating chains. The volume of oil delivered and the frequency of delivery are both adjustable.

The **TIMER** uses an electronic time switch, which can be set with 24-hour and 7-day programming, with six on/off set points. Three block programs allow for different weekday schedules. A manual override is provided for ON or OFF to the next scheduled event. Standby operation is provided for a minimum of seven days with a built-in rechargeable NiCad battery.

- ◆ Servo-Meter lubricant injector. 1-Drop capacity; optional 2-drop capacity.
- ◆ Up to four injectors and nozzles can be used.
- ◆ Snaplock® lubricant dispensing nozzle.
- ◆ Magnetic nozzle base.
- ◆ 2-Quart capacity lubricant reservoir. Other optional capacities.
- ◆ Built-in lockout valve.
- ◆ NPTF port threads; optional BSPP threads.

### GENERAL SPECIFICATIONS

**Ambient/Media Temperature:**

40° to 125°F (4° to 52°C).

**Body Blocks:** Anodized aluminum.

**Hose:** 6-feet long braided PVC. Longer or shorter hose in 1-foot increments.

**Injector:**

1-Drop-rated Servo-Meter; 0 to 0.027 ml per pulse. Optional 2-drop-rated Servo-Meter; 0 to 0.060 ml per pulse. Up to four injectors can be used.

**Inlet Port:**

1/4 NPTF; optional 1/8 NPTF. Optional BSPP threads.

**Inlet Pressure:** 60 to 120 psig (4 to 8 bar).

**Lubricant Viscosity:** 32–500 SUS @ 100°F (38°C).

**Nozzle:** Snaplock® with 12-inch flexible segmented plastic. Optional 18-inch or 24-inch lengths. Optional copper nozzles and fan tips.

**Reservoir:** 2-Quart capacity

**Seals:** Air, nitrile; oil, Viton.

### TIMER SPECIFICATIONS

**Accuracy:** ± 4 minutes per year.

**Ambient Temperature:** -14° to 130°F (-25° to 54°C).

**Display:** LCD with TIME, AM/PM, ON/OFF, and DAY indicators.

**Power Consumption:** 4 VA.

**Power Supply:**

120 V 50/60 Hz. Other voltages available.

**Standby System:** Internal rechargeable NiCad battery supplies standby operations for a minimum of 7 days.

**Switch Rating:** SPDT relay.

16 A @ 120 VAC (resistive).

1/2 HP @ 120 VAC.

1 HP @ 240 VAC.

1000 watts tungsten @ 120/240 VAC.

**Switch Timing:**

Presets programmable in 1-minute increments.

UL Approved.

<b>DIMENSIONS</b> inches (mm)	
A	12 (305) Std
B	72 (1830) Std
C	2.6 (66)
D	14 (356)
E	6.8 (172)
F	
2-Qt Reservoir (Std)	23.4 (594)
1-Qt Reservoir	17.4 (441)

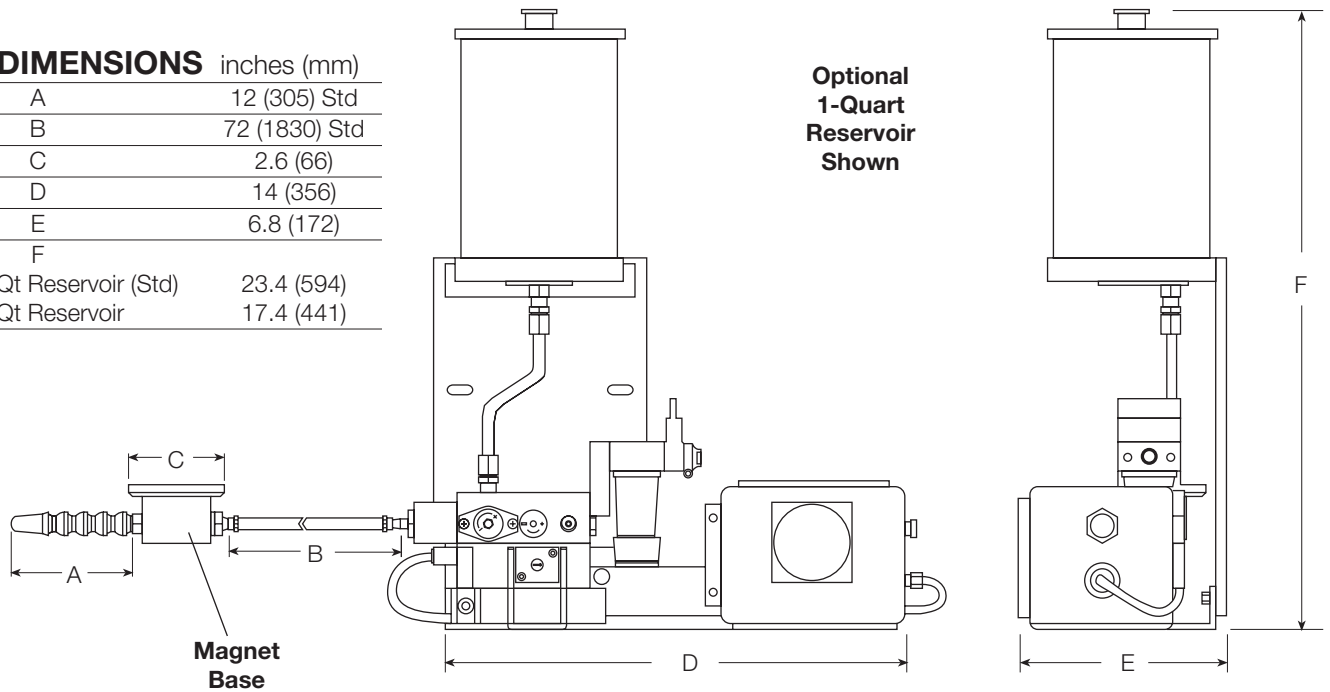

### ORDERING INFORMATION

Change the letters in the sample model number below to specify the Viper assembly you want.

**87 C B 1 1 3 0 2 T 06 K A 1**

#### ELECTRICAL

- 110 volts 50/60 Hz mini plug ..... C
- 24 VDC mini plug ..... E

#### EXTENDED BRACKET

- For 1-qt and 2-qt reservoirs ..... B
- No bracket (no reservoir) ..... C

#### NUMBER OF INJECTORS/NOZZLES

Specify number from 1 to 4.

#### INJECTOR RATING

- 1 Drop (Std) ..... 1
- 2 Drops ..... 2
- 1/2 Drop ..... 5

#### RESERVOIR

- No reservoir or mounting plate ..... 1
- 1-Qt with mounting plate ..... 2
- 2-Qt with mounting plate (Std) ..... 3

#### NOZZLE BASE ("C" in drawing above)

- Magnetic ..... 0
- No base ..... 1

#### INLET PORT

- 1/8 NPTF ..... 1
- 1/4 NPTF ..... 2
- 1/8 BSPP ..... A
- 1/4 BSPP ..... B

#### NOZZLE

- Standard conical tip ..... 1
- Fan tip ..... 2

#### NOZZLE LENGTH

- 12 inches (305 mm) (Std) ..... A
- 18 inches (457 mm) ..... B
- 24 inches (610 mm) ..... C
- 36 inches (914 mm) ..... D

#### NOZZLE TYPE

- Snaplock® (Std) ..... K
- Copper ..... H

#### HOSE LENGTH

- None ..... 00
- 6 Feet (1.8 m) (Std) ..... 06
- Specify desired length (in feet) with two digits. For example, 08 for 8 feet, 12 for 12 feet ..... \*\*

#### HOSE TYPE

- Braided PVC hose (Std) ..... T
- Teflon tubing with braided shielding with capillary tubing. (Copper cap tubing in all copper nozzle sections) ..... S

# INTEGRAL FILTER/REGULATOR plus LUBRICATOR ASSEMBLIES (FRLs)

The integration of a general purpose filter and a pressure regulator into a single module provides the compactness needed where space is limited. These integral filter/regulators are offered by Master Pneumatic in port sizes from 1/8 up to 3/4 along with **SENTRY** models equipped with quick-connect fittings for tubing from 1/4 up to 10 mm.

When an integral filter/regulator is paired with a lubricator, joined either by a modular connector or a pipe nipple, the assembly makes a complete **FRL** with nothing lost in performance, but with the advantage of compactness to fit in tight spaces.

All filter/regulators include an internal automatic filter drain and a pressure gauge as standard equipment, and regulators are either self-relieving or non-relieving. **SENTRY**, **GUARDSMAN**, and **SERIES 380** assemblies include a lockout valve for added safety.

Available options are the same as those for the corresponding individual filters, regulators, and lubricators. They include regulating springs for various pressure ranges, metal filter bowls, and sintered bronze filter elements in several  $\mu\text{m}$  ratings, as well as quick-fill caps for the lubricators. All assemblies, except Miniatures, now include a lockout valve for increased safety.



## GUIDE to INTEGRAL FILTER/REGULATORS plus LUBRICATORS

Series	Modular Construction	Port Sizes					Pages
		1/8	1/4	3/8	1/2	3/4	
<b>SENTRY</b>							
VCFDRL10, 11 models †	yes	X	X				240-241
<b>MINIATURE</b>							
CFDRL55, 56 models	no	X	X				242-243
<b>GUARDSMAN</b>							
MVCFDRL60D models	yes		X	X	X		244-245
<b>GUARDSMAN II</b>							
BMVCFDRL70D models	yes		X	X	X		246-247
<b>Full-Size VANGUARD</b>							
MVCFDRL108D models	yes		X	X	X	X	248-249
MVCFDRL108W models	yes		X	X	X	X	250-251
<b>Full-Size SERIES 380</b>							
AAM3A0B1A1 models	yes			X	X	X	252-253

† Also available with quick-connect fittings for tubing up to 10 mm.

# FILTER-REGULATOR-LUBRICATOR ASSEMBLIES (FRLs)

FRL assemblies offer an enormous variety of combinations to fit the needs of almost every filtration, pressure regulation, and lubrication requirement. The FRLs shown in this catalog cover only a portion of these needs in port sizes from 1/8 to 1-1/2. Featured are the configurations most widely used, but FRLs in many other configurations are readily assembled.

All standard **SENTRY**, **GUARDSMAN**, **Full-Size VANGUARD**, and **SERIES 380** assemblies now include a lockout valve for added safety.

General purpose filter-regulator-lubricator assemblies are the most widely used, but other combinations meet a variety of needs. For example, where air line lubrication is not needed, a filter-regulator combination may be sufficient. This can consist of an individual filter and regulator or a compact integral filter/regulator.

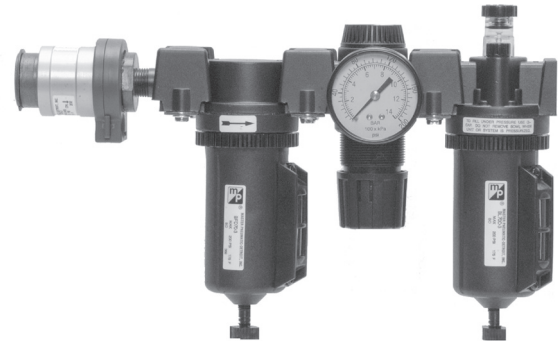

## GUIDE to FILTER-REGULATOR-LUBRICATOR COMBINATIONS

Series	Modular Construction	Port Sizes							Pages	
		1/8	1/4	3/8	1/2	3/4	1	1-1/4		1-1/2
<b>SENTRY</b>										
VFDRL 10, 11 models †	yes	X	X							254-255
<b>MINIATURE</b>										
FDRL 55, 56	no	X	X							256-257
<b>GUARDSMAN</b>										
MVFDRL60D models	yes		X	X	X					258-259
<b>GUARDSMAN II</b>										
BMVFDRL70D models	yes		X	X	X					260-261
<b>Full-Size VANGUARD Series</b>										
MVFDRL108D models	yes		X	X	X	X				262-263
MVFDRL108W models	yes		X	X	X	X				264-265
<b>Full-Size SERIES 380</b>										
AAMV1A1B1A1 models	yes			X	X	X				266-267
<b>High-Capacity VANGUARD</b>										
FDRL180 models	no					X	X			268-269
FDRL189D models	no					X	X	X	X	270-271
BFDR289D models	no							X	X	272-273

† Also available with quick-connect tube fittings up to 10 mm.

# SENTRY Modular FRLs Integral Filter/Regulators plus Lubricator

# VCFDRL10 and 11 Models Port Sizes: 1/8, 1/4 Tube Fittings



Model Shown: VCFDRL10-2

- ◆ Filter and regulator consolidated in a single assembly (**CFDR10M** or **CFDR11M**); wick-feed lubricator (**L10**); lockout valve (**V10**).
- ◆ Modular assembly and mounting.
- ◆ Threaded ports or quick-connect fittings for tubing up to 10 mm in diameter.
- ◆ 5- $\mu$ m-rated polyethylene filter element; optional sintered bronze elements.
- ◆ High-strength polycarbonate plastic bowls or aluminum bowls.
- ◆ Internal automatic filter drain; optional manual drain.
- ◆ Piston-type regulator (**CFDRL10** models) or diaphragm-type (**CFDRL11** models).
- ◆ Self-relieving regulator; non-relieving optional.
- ◆ Pressure gauge.
- ◆ **NPTF** port threads; optional **BSPP** threads.

## SPECIFICATIONS

### Ambient/Media Temperature:

40° to 125°F (4° to 52°C).

**Bowls:** 2-Ounce (60-ml) capacity polycarbonate plastic bowls or aluminum bowls.

### Filter Drain:

Internal automatic drain; optional manual drain.

**Filter Element:** 5- $\mu$ m-rated polyethylene; optional 5- $\mu$ m, 20- $\mu$ m, or 40- $\mu$ m sintered bronze.

**Filter/Regulator & Lubricator Bodies:** Acetal.

**Fluid Media:** Compressed air.

### Inlet Pressure:

15 psig (1 bar) minimum with automatic drain.  
150 psig (10 bar) maximum.

**Oil Adjustment:** External, no shutoff.

**Outlet Pressure:** Adjustable up to 100 psig (7 bar).

**Pressure Gauge:** 0 to 160 psig (10.3 bar); 1/8 NPT gauge ports front and rear.

**Panel Mounting:** 1-3/16 inch (30 mm) hole required.

**Regulator Dome and Knob:** Acetal.

**Seals:** Nitrile.

### AIR FLOW DATA

See Flow Charts for individual assembly components on preceding pages.



## DIMENSIONS inches (mm)

Ports	A *	B #	C	Depth †	Weight lb (kg)
1/8, 1/4	5.2 (132)	3.6 (92)	2.6 (67)	1.8 (45)	0.57 (0.32)
<b>Models below have quick-connect fittings for tubing.</b>					
1/4	5.6 (142)	3.6 (92)	2.6 (67)	1.8 (45)	0.55 (0.31)
3/8	6.2 (157)	3.6 (92)	2.6 (67)	1.8 (45)	0.55 (0.31)
4 mm	5.7 (145)	3.6 (92)	2.6 (67)	1.8 (45)	0.55 (0.31)
6 mm	5.7 (145)	3.6 (92)	2.6 (67)	1.8 (45)	0.55 (0.31)
8 mm	5.3 (135)	3.6 (92)	2.6 (67)	1.8 (45)	0.55 (0.31)
10 mm	6.2 (157)	3.6 (92)	2.6 (67)	1.8 (45)	0.55 (0.31)

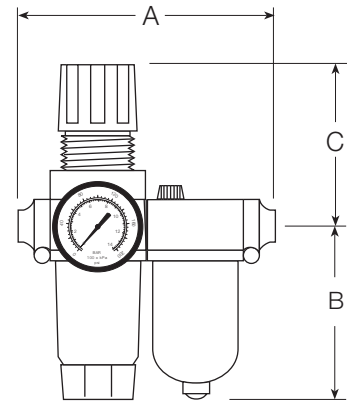

\* Without V10 lockout valve deduct 0.6 (15) from dimension A.

† Less gauge.

# Dimension for plastic bowl; metal bowl is 4.3 (109).

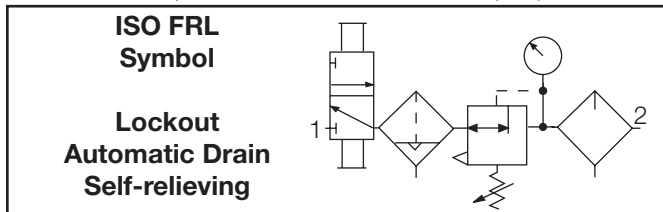

## REPLACEMENT FILTER ELEMENT KITS

Element Type	Kit Number
5-µm polyethylene (Std element).....	KA130-27PE5
5-µm bronze .....	KA130-27E5
20-µm bronze .....	KA130-27E4
40-µm bronze .....	KA130-27E3

## ORDERING INFORMATION

Change the letters in the sample model number below to specify the F/R + L you want.  
**NOTE:** For model numbers longer than 15 characters, please consult Master Pneumatic.

### B V C F D R L 10 P - 2 X Y G W

#### BOWL TYPE

Plastic bowl.....Leave Blank  
 Metal bowl.....B

#### LOCKOUT VALVE

V10 Valve ..... V  
 No valve ..... Leave Blank

#### FILTER DRAIN

Internal automatic drain.....CFD  
 Manual drain.....CF

#### REGULATOR TYPE

Piston type ..... 10  
 Diaphragm type..... 11

#### MOUNTING HOLE LOCATION

Bottom mount (Standard) ..... Leave Blank  
 Top mount ..... P

#### INLET PORT SIZE

No inlet and outlet ports ..... Leave Blank  
 Threaded:  
   1/8 NPTF.....1  
   1/4 NPTF.....2  
 Fittings for Tubing:  
   1/4.....04  
   3/8.....06  
   4 mm.....M4  
   6 mm.....M6  
   8 mm.....M8  
   10 mm.....M10

#### OUTLET PORT SIZE

Same as inlet port .... Leave Blank  
 Threaded:  
   1/8 NPTF..... 1  
   1/4 NPTF..... 2  
 Fittings for Tubing:  
   1/4..... 04  
   3/8..... 06  
   4 mm..... M4  
   6 mm..... M6  
   8 mm..... M8  
   10 mm..... M10

#### PORT TYPE

As specified in **INLET PORT** .. Leave Blank  
 BSSPP threads on both ports ..... W

#### OPTIONS (More than one option can be chosen)

0-160 psig Gauge ..... Standard  
 No Gauge..... NG  
 Plastic mounting nut..... P  
 Metal mounting nut..... PN  
 Hex plastic mounting nut ..... PE

#### OPTIONS (More than one option can be chosen)

None ..... Leave Blank  
 Non-relieving regulator..... A  
 Sintered bronze filter element:  
   5-µm rating..... E5  
   20-µm rating..... E4  
   40-µm rating..... E3  
 Adjusting springs:  
   0-125 psig (0-8.6 bar)..... H  
   0-50 psig (0-3.4 bar)..... L  
   0-8 psig (0-0.6 bar)..... L8  
   0-15 psig (0-1.0 bar)..... L15  
   0-30 psig (0-2.1 bar)..... L30  
 Tamper-resistant spinning knob (psig preset) ..... MV(\*)  
 Quick-fill lubricator Q-cap ..... Q  
 Viton seals..... V

\*Insert preset pressure.

# MINIATURE FRLs

## Integral Filter/Regulators plus Lubricator

# CFDRL55 and 56 Models

## Port Sizes: 1/8, 1/4



- ◆ Filter and regulator consolidated in a single assembly (**CFDR55M** or **CFDR56M**); wick-feed lubricator (**L50**).
- ◆ Inline mounting.
- ◆ 5- $\mu$ m-rated polyethylene filter element; optional sintered bronze elements.
- ◆ High-strength polycarbonate plastic bowls or aluminum bowls.
- ◆ Internal automatic filter drain; optional manual drain.
- ◆ Piston-type regulator (**CFDRL55** models) or diaphragm-type (**CFDRL56** models).
- ◆ Self-relieving regulator; non-relieving optional.
- ◆ Pressure gauge.
- ◆ **NPTF** port threads; optional **BSPB** threads or fittings for tubing up to 10 mm.

### SPECIFICATIONS

#### Ambient/Media Temperature:

**Plastic bowls:** 40° to 125°F (4° to 52°C).

**Metal bowls:** 40° to 175°F (4° to 79°C).

**Bodies:** Aluminum for filter/regulator and lubricator.

**Bowls:** 2-Ounce (60-ml) capacity polycarbonate plastic bowls or aluminum bowls.

#### Filter Drain:

Internal automatic drain; optional manual drain.

**Filter Element:** 5- $\mu$ m-rated polyethylene; optional 5- $\mu$ m, 20- $\mu$ m, or 40- $\mu$ m sintered bronze.

**Fluid Media:** Compressed air.

#### Inlet Pressure:

15 psig (1 bar) minimum with automatic drain.

Plastic bowls: 150 psig (10 bar) maximum.

Metal bowls: 200 psig (13.7 bar) maximum.

**Oil Adjustment:** Internal; tamper-resistant.

**Outlet Pressure:** Adjustable up to 100 psig (7 bar).

**Pressure Gauge:** 0 to 160 psig (10.3 bar); 1/8 NPT gauge ports front and rear.

**Panel Mounting:** 1-3/16 inch (30 mm) hole required.

**Regulator Dome and Knob:** Acetal.

**Seals:** Nitrile.

### AIR FLOW DATA

See Flow Charts for individual assembly components on preceding pages.

## DIMENSIONS inches (mm)

Bowl	A	B	C	Depth †	Weight lb (kg)
Plastic	3.7 (94)	3.6 (92)	2.6 (67)	1.6 (41)	0.66 (0.30)
Metal	4.0 (101)	4.3 (109)	2.6 (67)	1.6 (41)	0.66 (0.30)

† Less gauge.

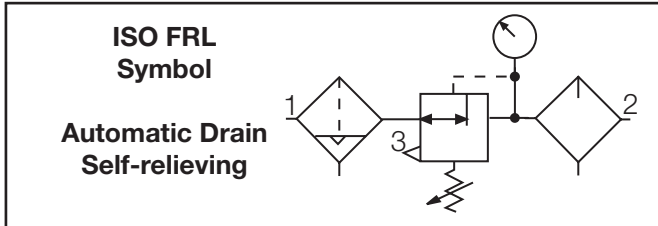
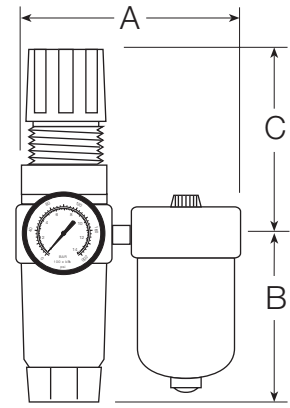

## REPLACEMENT FILTER ELEMENT KITS

Element Type	Kit Number
5- $\mu$ m polyethylene (Std element).....	KA130-27PE5
5- $\mu$ m bronze .....	KA130-27E5
20- $\mu$ m bronze .....	KA130-27E4
40- $\mu$ m bronze .....	KA130-27E3

## ORDERING INFORMATION

Change the letters in the sample model number below to specify the F/R + L you want.  
**NOTE:** For model numbers longer than 15 characters, please consult Master Pneumatic.

**B CFD RL 55 - 2 Y X W**

### BOWL TYPE

Plastic bowl.....Leave Blank  
 Metal bowl.....B

### FILTER DRAIN

Internal automatic drain ..... CFD  
 Manual drain.....CF

### REGULATOR TYPE

Piston type .....55  
 Diaphragm type.....56

### PORT SIZE

1/8 NPTF.....1  
 1/4 NPTF.....2

### PORT TYPE

NPTF Threads ..... Leave Blank  
 BSPP threads ..... W

### OPTIONS (More than one option can be chosen)

0-160 psig Gauge ..... Standard  
 No Gauge..... NG  
 No Gage Ports on Head ..... NP  
 Plastic mounting nut.....P  
 Metal mounting nut.....PN  
 Hex plastic mounting nut.....PE

### OPTIONS (More than one option can be chosen)

None .....Leave Blank  
 Non-relieving regulator.....A  
 Sintered bronze filter element:

5- $\mu$ m rating.....E5  
 20- $\mu$ m rating.....E4  
 40- $\mu$ m rating.....E3

### Adjusting springs:

0-125 psig (0-8.6 bar).....H  
 0-50 psig (0-3.4 bar).....L  
 0-8 psig (0-0.6 bar).....L8  
 0-15 psig (0-1.0 bar).....L15  
 0-30 psig (0-2.1 bar).....L30

### Tamper-resistant spinning

knob (psig preset) ..... MV(\*)  
 Quick-fill lubricator Q-cap .....Q  
 Viton seals.....V

\*Insert preset pressure.

# GUARDSMAN Modular FRLs Integral Filter/Regulators plus Lubricator

# MVCFDRL60D Models Port Sizes: 1/4, 3/8, 1/2

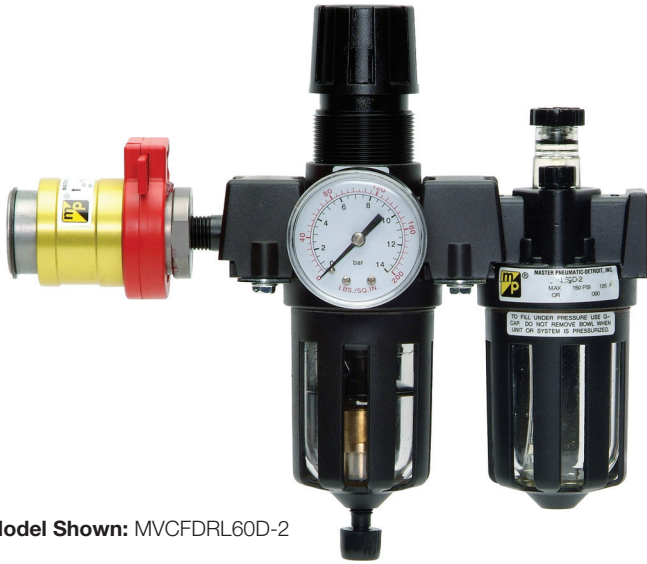

Model Shown: MVCFDRL60D-2

- ◆ Filter and regulator consolidated in a single assembly (CFDR60); sight-feed lubricator (L60D); lockout valve (V35).
- ◆ Modular or inline mounting.
- ◆ 5- $\mu$ m-rated polyethylene filter element; optional sintered bronze elements.
- ◆ High-strength zinc bowl or polycarbonate plastic bowl with shatterguard.
- ◆ Internal automatic filter drain; optional manual drain.
- ◆ Self-relieving piston-type regulator; non-relieving optional.
- ◆ Pressure gauge.
- ◆ NPTF port threads; optional SAE or BSPP threads.

## SPECIFICATIONS

### Ambient/Media Temperature:

40° to 125°F (4° to 52°C). With metal bowls but no lockout valve: 40° to 175°F (4° to 79°C).

**Bodies:** Zinc for filter/regulator and lubricator.

**Bowls:** 4-Ounce (120-ml) capacity zinc bowls or polycarbonate plastic bowls with zinc shatterguards.

### Filter Drain:

Internal automatic drain; optional manual drain.

**Filter Element:** 5- $\mu$ m-rated polyethylene; optional 5- $\mu$ m, 20- $\mu$ m, or 40- $\mu$ m sintered bronze.

**Fluid Media:** Compressed air.

### Inlet Pressure:

15 psig (1 bar) minimum with automatic drain.  
150 psig (10 bar) maximum. With metal bowls but no lockout valve: 200 psig (13.7 bar) maximum.

**Oil Adjustment:** External; tamper-resistant.

**Outlet Pressure:** Adjustable up to 100 psig (7 bar).

**Pressure Gauge:** 0 to 200 psig (14 bar); 1/4 NPT gauge ports front and rear.

**Panel Mounting:** 1-9/16 inch (40 mm) hole required.

**Regulator Dome and Knob:** Acetal.

**Seals:** Nitrile.

**Sight Dome:** Clear nylon.

## AIR FLOW DATA

See Flow Charts for individual assembly components on preceding pages.

## DIMENSIONS inches (mm)

Bowl	A *	B	C	Depth †	Weight lb (kg)
Metal	8.7 (221)	4.6 (116)	3.3 (83)	2.4 (61)	2.94 (1.34)
Plastic	8.7 (221)	4.6 (116)	3.3 (83)	2.4 (61)	2.94 (1.34)

\* Without V35 lockout valve deduct 3.8 (97) from dimension A.

† Less gauge.

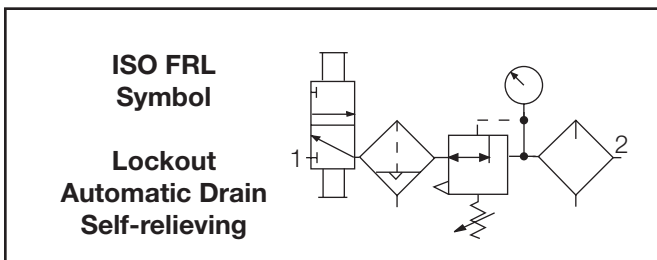
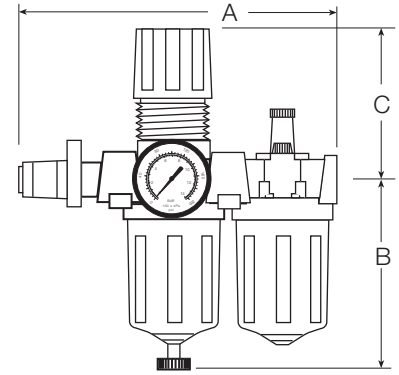

## REPLACEMENT FILTER ELEMENT KITS

Element Type	Kit Number
5-µm polyethylene (Std element).....	KA130-27PE5
5-µm bronze .....	KA130-27E5
20-µm bronze .....	KA130-27E4
40-µm bronze .....	KA130-27E3

## ORDERING INFORMATION

Change the letters in the sample model number below to specify the F/R + L you want.

**NOTE:** For model numbers longer than 15 characters, please consult Master Pneumatic.

### B M V CFD RL60D - 2 Y X W

#### BOWL TYPE

Plastic bowl.....Leave Blank  
Metal bowl.....B

#### ASSEMBLY

Modular.....M  
Pipe nipple.....Leave Blank

#### LOCKOUT VALVE

V35 Valve.....V  
No valve.....Leave Blank

#### FILTER DRAIN

Internal automatic drain.....CFD  
Manual drain.....CF

#### PORT SIZE

1/4 NPTF.....2  
3/8 NPTF.....3  
1/2 NPTF.....4  
9/16-18 UNF SAE.....S6

#### PORT TYPE

NPTF Threads.....Leave Blank  
BSPP threads.....W

#### OPTIONS (More than one option can be chosen)

0-200 psig Gauge.....Standard  
No Gauge.....NG  
Plastic Mounting nut.....P

#### OPTIONS (More than one option can be chosen)

None.....Leave Blank  
Non-relieving regulator.....A  
Sintered bronze filter element:  
5-µm rating.....E5  
20-µm rating.....E4  
40-µm rating.....E3  
Adjusting springs:  
0-150 psig (0-10 bar).....H  
0-50 psig (0-3.4 bar).....L  
Quick-fill lubricator Q-cap.....Q

# GUARDSMAN II Modular FRLs

## Integral Filter/Regulators plus Lubricator

# BMVCFDRL70D Models

## Port Sizes: 1/4, 3/8, 1/2

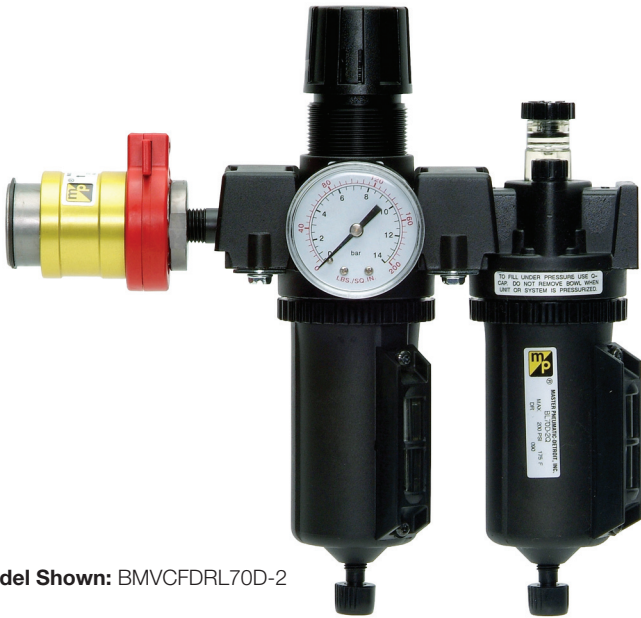

Model Shown: BMVCFDRL70D-2

- ◆ Filter and regulator consolidated in a single assembly (**BCFDR70**); sight-feed lubricator (**BL70D**); lockout valve (**V35**).
- ◆ Modular or inline mounting.
- ◆ 5- $\mu$ m-rated polyethylene filter element; optional sintered bronze elements.
- ◆ Aluminum bowls with clear nylon sight glass. Bowls can be rotated for easy readability.
- ◆ Optional extended bowls provide greater filter sump and lubricator capacities.
- ◆ Internal automatic filter drain; optional manual drain.
- ◆ Self-relieving piston-type regulator; non-relieving optional.
- ◆ Pressure gauge.
- ◆ **NPTF** port threads; optional **SAE** or **BSPP** threads.

## SPECIFICATIONS

### Ambient/Media Temperature:

40° to 125°F (4° to 52°C).

**Without lockout valve:** 40° to 175°F (4° to 79°C).

**Bodies:** Zinc for filter/regulator and lubricator.

**Bowls:** 6-Ounce (180-ml) capacity aluminum bowls with clear nylon sight glass. Optional 10-ounce (300-ml) bowls. Bowls can be rotated for easy readability.

**Bowl Rings:** Nylon.

### Filter Drain:

Internal automatic drain; optional manual drain.

**Filter Element:** 5- $\mu$ m-rated polyethylene; optional 5- $\mu$ m or 40- $\mu$ m sintered bronze.

**Fluid Media:** Compressed air.

### Inlet Pressure:

15 psig (1 bar) minimum with automatic drain.

150 psig (10 bar) maximum.

Without lockout valve: 200 psig (13.7 bar) maximum.

**Oil Adjustment:** External; tamper-resistant.

**Outlet Pressure:** Adjustable up to 100 psig (7 bar).

Pressure Gauge: 0 to 200 psig (14 bar); 1/4 NPT gauge ports front and rear.

**Panel Mounting:** 1-9/16 inch (40 mm) hole required.

**Regulator Dome and Knob:** Acetal.

**Seals:** Nitrile.

**Sight Dome:** Clear nylon.

## AIR FLOW DATA

See Flow Charts for individual assembly components on preceding pages.

## DIMENSIONS inches (mm)

Bowl	A *	B	C	Depth †	Weight † lb (kg)
Standard	8.7 (221)	5.9 (151)	3.3 (83)	2.4 (60)	3.00 (1.36)
Extended	8.7 (221)	8.9 (227)	3.3 (83)	2.4 (60)	5.25 (2.39)

\* Without V35 lockout valve deduct 3.8 (97) from dimension A.

† Less gauge.

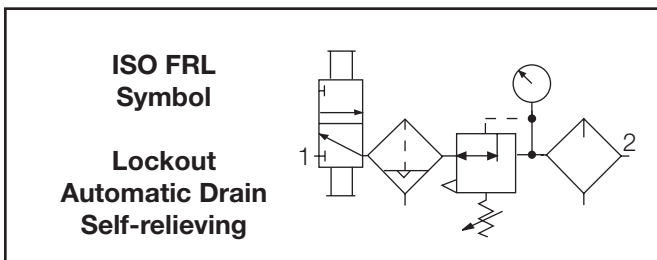
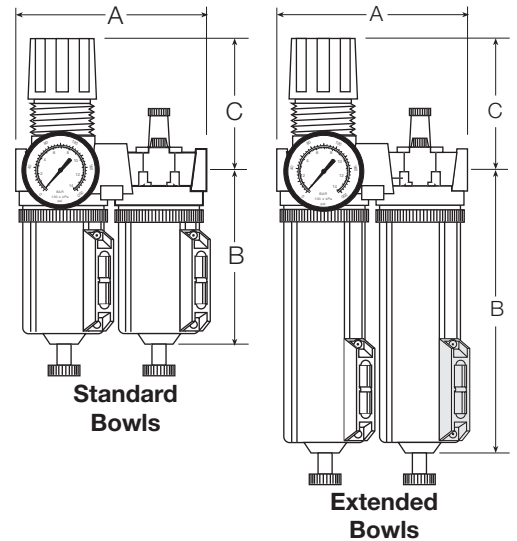

## REPLACEMENT FILTER ELEMENT KITS

Element Type	Kit Number
5- $\mu$ m polyethylene (Std element).....	KA60F-03PE5
5- $\mu$ m bronze .....	KA60F-03E5
40- $\mu$ m bronze .....	KA60F-03E3

## ORDERING INFORMATION

Change the letters in the sample model number below to specify the F/R + L you want.  
NOTE: For model numbers longer than 15 characters, please consult Master Pneumatic.

### B M V CFD RL 70D - 2 Y X W

#### LOCKOUT VALVE

V35 valve ..... V  
No valve ..... Leave Blank

#### FILTER DRAIN

Internal automatic drain ..... CFD  
Manual drain ..... CF

#### BOWL SIZE

Standard 6-ounce bowls ..... 70D  
Extended 10-ounce bowls ..... 70DH

#### PORT SIZE

1/4 NPTF ..... 2  
3/8 NPTF ..... 3  
1/2 NPTF ..... 4  
9/16-18 UNF SAE ..... S6

#### PORT TYPE

NPTF Threads ..... Leave Blank  
BSPP threads ..... W

#### OPTIONS (More than one option can be chosen)

0-200 psig Gauge ..... Standard  
No gauge ..... NG  
Plastic nut ..... P

#### OPTIONS (More than one option can be chosen)

None ..... Leave Blank  
Non-relieving regulator ..... A  
Sintered bronze filter element:

5- $\mu$ m rating ..... E5  
20- $\mu$ m rating ..... E4  
40- $\mu$ m rating ..... E3

#### Adjusting springs:

0-150 psig (0-10 bar) ..... H  
0-50 psig (0-3.4 bar) ..... L  
Quick-fill lubricator Q-cap ..... Q

# VANGUARD Modular FRLs Integral Filter/Regulators plus Lubricator

# MVCFDRL108D Models Port Sizes: 1/4, 3/8, 1/2, 3/4



**Model Shown:**  
MVCFDRL108D-6

## SPECIFICATIONS

### **Ambient/Media Temperature:**

40° to 125°F (4° to 52°C). With metal bowls but no lockout valve: 40° to 175°F (4° to 79°C).

**Bodies:** Zinc for filter/regulator and lubricator.

**Bowls:** 8-Ounce (240-ml) capacity zinc bowls with clear nylon sight glass or polycarbonate plastic bowls with steel shatterguard. Optional 20-ounce (600-ml) extended lubricator bowl.

**Bowl Rings:** Nylon.

### **Filter Drain:**

Internal automatic drain; optional manual drain or external Hydro-Jector drain.

**Filter Element:** 5- $\mu$ m-rated polyethylene; optional 5- $\mu$ m, 20- $\mu$ m, or 40- $\mu$ m sintered bronze.

**Fluid Media:** Compressed air.

### **Inlet Pressure:**

15 psig (1 bar) minimum with automatic drain.  
150 psig (10 bar) maximum. With metal bowls but no lockout valve: 200 psig (13.7 bar) maximum.

**Oil Adjustment:** External; tamper-resistant.

**Outlet Pressure:** Adjustable up to 125 psig (8.6 bar).

**Pressure Adjustment Locking Key:** Removable.

**Pressure Gauge:** 0 to 200 psig (14 bar); 1/4 NPT gauge ports front and rear.

**Regulator:** Nylon dome; acetal knob.

**Seals:** Nitrile.

**Sight Dome:** Clear nylon.

- ◆ Filter and regulator consolidated in a single assembly (**CFDR100**); sight-feed lubricator (**L28D**); lockout valve (**V35**).
- ◆ Modular or inline mounting.
- ◆ 5- $\mu$ m-rated polyethylene filter element; optional sintered bronze elements.
- ◆ Zinc bowls with clear nylon sight glass or polycarbonate plastic bowls with steel shatterguard.
- ◆ Internal automatic filter drain; optional manual drain or external Hydro-Jector drain.
- ◆ Self-relieving diaphragm-type regulator; non-relieving optional.
- ◆ Pressure gauge.
- ◆ **NPTF** port threads; optional **SAE** or **BSPP** threads.

## AIR FLOW DATA

See Flow Charts for individual assembly components on preceding pages.



## DIMENSIONS inches (mm)

Bowls	A *	B	C	Depth †	Weight † lb (kg)
Std. Plastic	10.5 (267)	5.8 (147)	3.3 (84)	3.5 (89)	5.94 (2.69)
Std. Metal	10.5 (267)	6.4 (163)	3.3 (84)	3.5 (89)	7.74 (3.51)
Extended Metal	10.5 (267)	9.8 (249)	3.3 (84)	3.5 (89)	9.63 (4.37)

\*Without V35 lockout valve deduct 3.8 (97) from dimension A.  
† Less gauge.

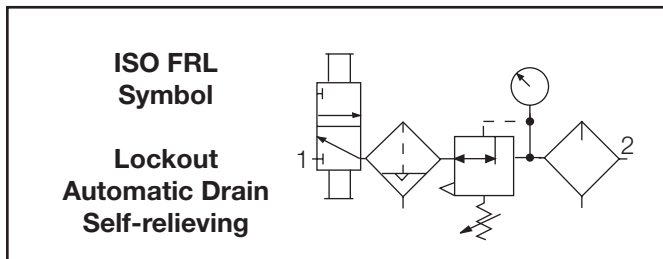
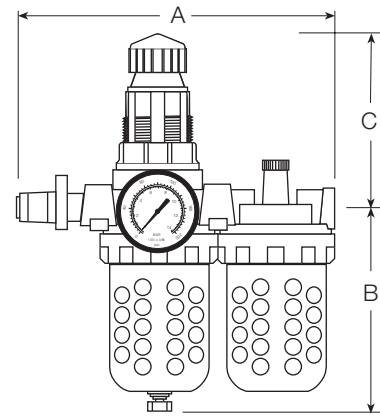

## REPLACEMENT FILTER ELEMENT KITS

Element Type	Kit Number
5-µm polyethylene (Std element).....	KA103-3PE
5-µm bronze .....	KA103-3PE5
20-µm bronze .....	KA103-3PE4
40-µm bronze .....	KA103-3PE3

## ORDERING INFORMATION

Change the letters in the sample model number below to specify the F/R + L you want.  
**NOTE:** For model numbers longer than 15 characters, please consult Master Pneumatic.

**B M V CFD RL 108D - 2 Y W**

### BOWL TYPE

Metal bowls ..... B  
Plastic bowls ... leave Blank

### ASSEMBLY

Modular ..... M  
Pipe nipple ..... Leave Blank

### LOCKOUT VALVE

V35 Valve ..... V  
No valve ..... Leave Blank

### FILTER DRAIN

Internal automatic drain ..... CFD  
Manual drain.....CF  
External Hydro-Jector drain;  
only with metal bowl .....CFE

### BOWL SIZE

Standard 8-ounce bowls ..... 108D  
8-Ounce filter bowl &  
20-ounce lubricator bowl  
(metal bowls only) ..... 108DH

### PORT TYPE

NPTF Threads ..... Leave Blank  
BSPF threads ..... W

### OPTIONS (More than one option can be chosen)

None ..... Leave Blank  
Non-relieving regulator ..... A  
Sintered bronze filter element:  
5-µm rating ..... E5  
20-µm rating ..... E4  
40-µm rating ..... E3  
Adjusting springs:  
0-175 psig (0-12 bar) ..... H\*\*  
0-50 psig (0-3.4 bar) ..... L  
Remove adjusting key ..... JJ  
Metal Dome ..... MD  
Limit maximum psig setting .... M\*  
0-200 psig Gauge ..... Standard  
No gauge ..... NG  
Regulator tee handle ..... T  
Quick-fill lubricator Q-cap ..... Q

### PORT SIZE

1/4 NPTF..... 2  
3/8 NPTF..... 3  
1/2 NPTF..... 4  
3/4 NPTF..... 6  
9/16-18 UNF SAE ..... S6  
3/4-16 UNF SAE ..... S8  
7/8-14 UNF SAE ..... S10

\* Insert maximum limited pressure.

\*\* H option spring includes metal dome

# VANGUARD Modular FRLs Integral Filter/Regulators plus Lubricator

## MVCFDRL108W Models Port Sizes: 1/4, 3/8, 1/2, 3/4



**Model Shown:**  
MVCFDRL108W-4

- ◆ Filter and regulator consolidated in a single assembly (**CFDR100**); wick-feed lubricator (**L28W**); lockout valve (**V35**).
- ◆ Modular or inline mounting.
- ◆ 5- $\mu$ m-rated polyethylene filter element; optional sintered bronze elements.
- ◆ Zinc bowls with clear nylon sight glass or polycarbonate plastic bowls with steel shatterguard.
- ◆ Internal automatic filter drain; optional manual drain or external Hydro-Jector drain.
- ◆ Self-relieving diaphragm-type regulator; non-relieving optional.
- ◆ Pressure gauge.
- ◆ NPTF port threads; optional SAE or BSPP threads.

### SPECIFICATIONS

**Ambient/Media Temperature:**

40° to 125°F (4° to 52°C). With metal bowls but no lockout valve: 40° to 175°F (4° to 79°C).

**Bowls:** 8-Ounce (240-ml) capacity zinc bowls with clear nylon sight glass or polycarbonate plastic bowls with steel shatterguard.

**Bowl Rings:** Aluminum.

**Filter Drain:**

Internal automatic drain; optional manual drain or external Hydro-Jector drain.

**Filter Element:** 5- $\mu$ m-rated polyethylene; optional 5- $\mu$ m, 20- $\mu$ m, or 40- $\mu$ m sintered bronze.

**Fluid Media:** Compressed air.

**Heads:** Zinc.

**Inlet Pressure:**

15 psig (1 bar) minimum with automatic drain.  
150 psig (10 bar) maximum. With metal bowls but no lockout valve: 200 psig (13.7 bar) maximum.

**Oil Adjustment:** External; tamper-resistant.

**Outlet Pressure:** Adjustable up to 125 psig (8.6 bar).

**Pressure Adjustment Locking Key:** Removable.

**Pressure Gauge:** 0 to 200 psig (14 bar); 1/4 NPT gauge ports front and rear.

**Regulator:** Nylon dome; acetal knob.

**Seals:** Nitrile.

#### AIR FLOW DATA

See Flow Charts for individual assembly components on preceding pages.

**DIMENSIONS** inches (mm)

Bowls	A *	B	C	Depth †	Weight † lb (kg)
Plastic	10.5 (267)	5.8 (147)	3.3 (84)	3.5 (89)	5.94 (2.69)
Metal	10.5 (267)	6.4 (163)	3.3 (84)	3.5 (89)	7.74 (3.51)

\*Without V35 lockout valve deduct 3.8 (97) from dimension A.  
† Less gauge.

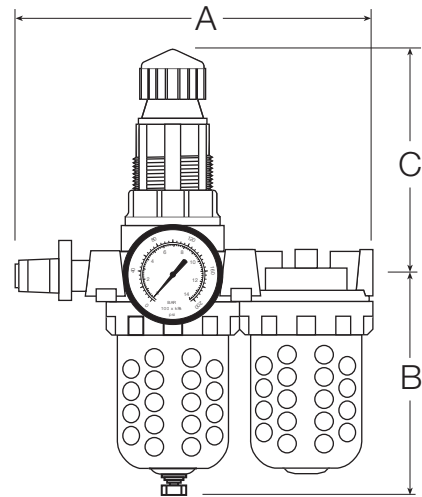

**REPLACEMENT FILTER ELEMENT KITS**

Element Type	Kit Number
5-µm polyethylene (Std element).....	KA103-3PE
5-µm bronze .....	KA103-3PE5
20-µm bronze .....	KA103-3PE4
40-µm bronze .....	KA103-3PE3

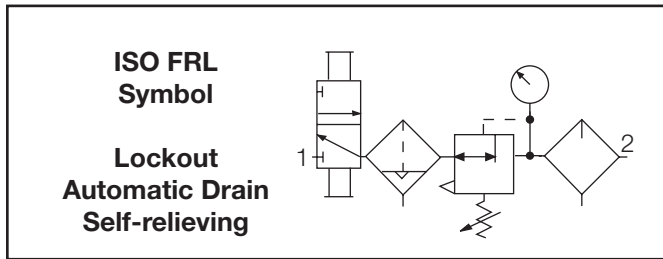

**ORDERING INFORMATION**

Change the letters in the sample model number below to specify the F/R + L you want.

**NOTE:** For model numbers longer than 15 characters, please consult Master Pneumatic.

**B M V CFD RL 108W - 2 Y W**

**BOWL TYPE**

Metal bowls ..... B  
Plastic bowls ...Leave Blank

**ASSEMBLY**

Modular .....M  
Pipe nipple .....Leave Blank

**LOCKOUT VALVE**

V35 Valve .....V  
None .....Leave Blank

**FILTER DRAIN**

Internal automatic drain ..... CFD  
Manual drain.....CF  
External Hydro-Jector drain;  
only with metal bowl .....CFE

**BOWL SIZE**

Standard 8-ounce bowls ..... 108W

**PORT TYPE**

NPTF Threads ..... Leave Blank  
BSPP threads ..... W

**OPTIONS** (*More than one option can be chosen*)

None .....Leave Blank  
Non-relieving regulator.....A  
Sintered bronze filter element:  
5-µm rating ..... E5  
20-µm rating ..... E4  
40-µm rating ..... E3  
Adjusting springs:  
0-175 psig (0-12 bar) .....H\*\*  
0-50 psig (0-3.4 bar) ..... L  
Remove adjusting key ..... JJ  
Metal Dome ..... MD  
Limit maximum psig setting .... M\*  
0-200 psig Gauge ..... Standard  
No gauge ..... NG  
Regulator tee handle ..... T  
Quick-fill lubricator Q-cap ..... Q

\* Insert maximum limited pressure.  
\*\* H option spring includes metal dome

**PORT SIZE**

1/4 NPTF.....2  
3/8 NPTF.....3  
1/2 NPTF.....4  
3/4 NPTF.....6  
9/16-18 UNF SAE .....S6  
3/4-16 UNF SAE .....S8  
7/8-14 UNF SAE .....S10

FRLs

# Full-Size SERIES 380 FRLs Integral Filter/Regulators plus Lubricator

# AAMV3A0B1A1 Models Port Sizes: 3/8, 1/2, 3/4

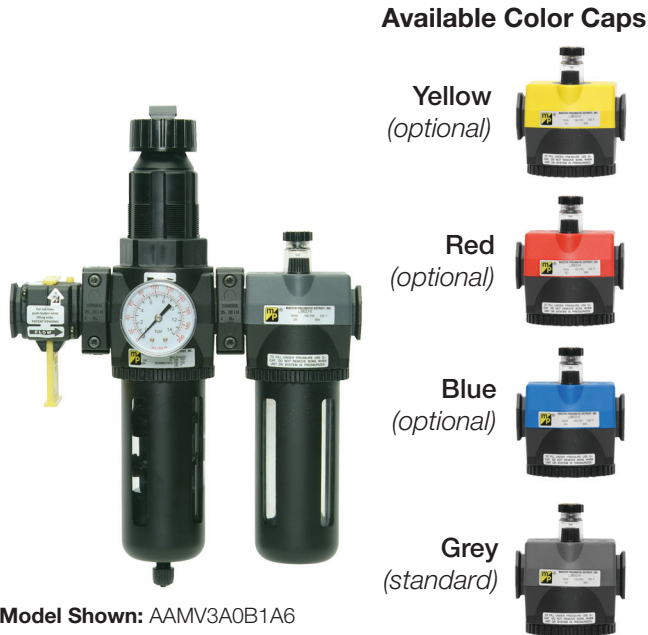

Model Shown: AAMV3A0B1A6

## SPECIFICATIONS

### Ambient/Media Temperature:

Metal bowls: 40° to 175°F (4° to 79°C).  
Plastic bowls: 40° to 125°F (4° to 52°C).

**Bowls:** 9-Ounce (270-ml) capacity aluminum bowls with clear nylon sight glass or polycarbonate plastic bowls with steel shatterguard. Optional 15-ounce (450-ml) extended aluminum lubricator bowl with two clear nylon sight glasses.

**Cap Colors:** Filter/regulator, black only. Lubricator, accent grey; yellow, red, and blue optional.

**Filter Drain:** Internal automatic drain; optional manual drain, or Warrior electronic drain.

**Filter Element:** 5-µm-rated polyethylene; optional 40-µm element.

**Fluid Media:** Compressed air.  
Heads: Zinc.

### Inlet Pressure:

15 psig (1 bar) minimum with automatic drain.  
Metal bowls: 200 psig (13.7 bar) maximum.  
Plastic bowls: 150 psig (10 bar) maximum.

**Oil Adjustment:** External; tamper-resistant.

**Outlet Pressure:** Adjustable up to 125 psig (8.6 bar).

**Pressure Adjustment Locking Key:** Removable.

**Pressure Gauge:** 0 to 200 psig (14 bar); 1/4 NPT gauge ports front and rear.

**Regulator Valve:** Brass.

**Seals:** Nitrile.

**Sight Dome:** Clear nylon.

- ◆ Filter and regulator consolidated in a single assembly (**CFDR380**); sight-feed lubricator (**L380D**); lockout valve (**V380**).
- ◆ Modular or inline mounting.
- ◆ 5-µm-rated polyethylene filter element; optional 40-µm element.
- ◆ Aluminum bowls with clear nylon sight glass or polycarbonate plastic bowls with steel shatterguard.
- ◆ Internal automatic filter drain; optional manual drain, or Warrior electronic drain.
- ◆ Optional extended aluminum lubricator bowl with sight glasses.
- ◆ Self-relieving diaphragm-type regulator; non-relieving optional.
- ◆ Pressure gauge; two gauge ports.
- ◆ **NPTF** port threads; optional **SAE** or **BSPP** threads.

## AIR FLOW DATA

See Flow Charts for individual assembly components on preceding pages.

## DIMENSIONS inches (mm)

Bowl	A *	B **	C	Depth †	Weight † lb (kg)
Standard	9.6 (244)	7.7 (195)	5.4 (137)	2.9 (73)	5.81 (2.64)
Extended	9.5 (241)	10.6 (269)	5.4 (137)	2.9 (73)	6.00 (2.73)

\* Without V380 lockout valve deduct 2.3 (58) from dimension A.

\*\* Bowl removal clearance: For 9-ounce plastic bowl add 4.2 (107).  
For 9-ounce metal bowl add 4.1 (104).  
For extended bowl add 6.1 (155).

† Less gauge.

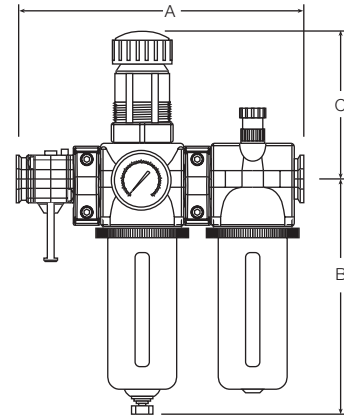

## REPLACEMENT FILTER ELEMENT KITS

Element Type	Kit Number
5-µm (Std element)	A115-106PE5
40-µm bronze	A115-106PE3

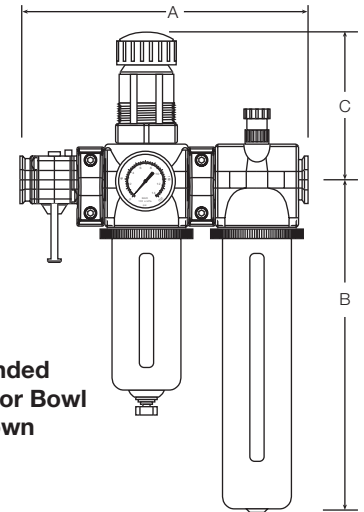
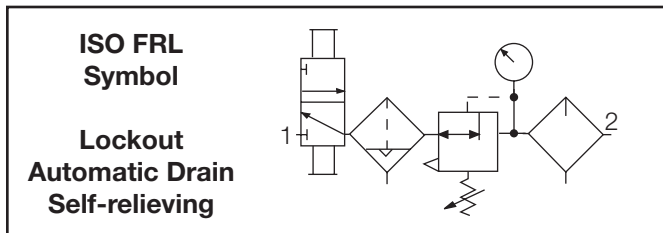

Extended  
Lubricator Bowl  
Shown

## ORDERING INFORMATION

Change the letters in the sample model number below to specify the F/R + L you want.  
To order with some of the other available options, see Ordering Information on page 291.

**A A M V 3 A 0 B 1 A 1 3**

### LUBRICATOR CAP COLOR

Accent Grey (Std) .... A  
MP Yellow..... B  
Red ..... C  
Mid Blue ..... D

### BOWL TYPE

Two 9-ounce plastic ..... A  
Two 9-ounce metal ..... B  
9-Ounce metal on F/R and  
15-ounce on lubricator ... D

### LOCKOUT VALVE

None ..... Leave Blank  
V380 Valve ..... V

### FILTER/REGULATOR MODEL

CFR380 (0-125 psig and ..... 3  
5-µm element)  
CFR380-E3 (0-125 psig and ... 4  
40-µm element)  
CFR380-H (0-175 psig and ..... 6 \*  
5-µm element)  
CFR380-L (0-50 psig and ..... 8  
5-µm element)

\* H option spring includes  
metal dome

### PORT SIZE

3/8 NPTF ..... 3  
1/2 NPTF ..... 4  
3/4 NPTF ..... 6  
3/8 BSPP ..... C  
1/2 BSPP ..... D  
3/4 BSPP ..... E  
3/4-16 UNF SAE ..... F  
7/8-14 UNF SAE ..... G

### GAUGES

None ..... 0  
200-BDD (0-200 psig) ..... 1  
60BDD (0-60 psig) ..... 2

### MOUNTING OPTIONS

No end ports ..... A  
Mounting brackets only ..... J  
Female ports and  
mounting brackets ..... K

### FILTER DRAIN

Manual ..... 0  
Internal automatic ..... 1  
Warrior electronic ..... 2

### LUBRICATOR

L380D ..... B  
L380D-Q (with quick-fill cap) ..... C

# SENTRY Modular FRLs Filter-Regulator-Lubricators

# VFDRL10 and 11 Models Port Sizes: 1/8, 1/4 Tube Fittings

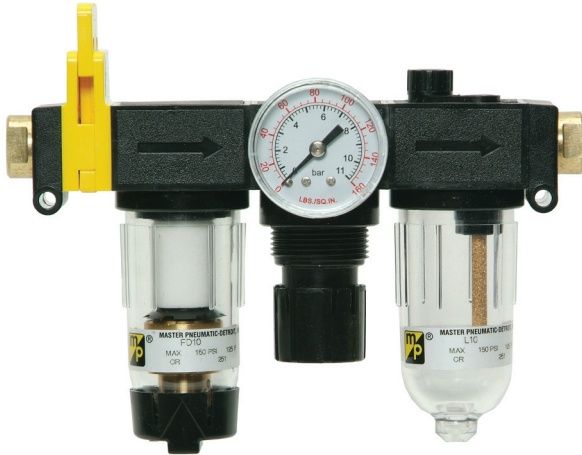

Model Shown: VFDRL10-2

- ◆ Individual filter (**FD10**); piston-type regulator (**R10M**) or diaphragm-type (**R11M**); wick-feed lubricator (**L10**); lockout valve (**V10**).
- ◆ Modular assembly and mounting.
- ◆ Threaded ports or quick-connect fittings for tubing up to 10 mm in diameter.
- ◆ 5- $\mu$ m-rated polyethylene filter element; optional sintered bronze elements.
- ◆ High-strength polycarbonate plastic bowls or aluminum bowls.
- ◆ Internal automatic filter drain; optional manual drain.
- ◆ Self-relieving regulator; non-relieving optional.
- ◆ Pressure gauge.
- ◆ NPTF port threads; optional BSPP threads.

## SPECIFICATIONS

### Ambient/Media Temperature:

40° to 125°F (4° to 52°C).

**Bodies:** Acetal.

**Bowls:** 2-Ounce (60-ml) capacity polycarbonate plastic bowls or aluminum bowls.

### Filter Drain:

Internal automatic drain; optional manual drain.

**Filter Element:** 5- $\mu$ m-rated polyethylene; optional 5- $\mu$ m, 20- $\mu$ m, or 40- $\mu$ m sintered bronze.

**Fluid Media:** Compressed air.

### Inlet Pressure:

15 psig (1 bar) minimum with automatic drain.  
150 psig (10 bar) maximum.

**Oil Adjustment:** External, no shutoff.

**Outlet Pressure:** Adjustable up to 100 psig (7 bar).

**Pressure Gauge:** 0 to 160 psig (10.3 bar); 1/8 NPT gauge ports front and rear.

**Panel Mounting:** 1-3/16 inch (30 mm) hole required.

**Regulator Dome and Knob:** Acetal.

**Seals:** Nitrile.

### AIR FLOW DATA

See Flow Charts for individual assembly components on preceding pages.

## DIMENSIONS inches (mm)

Ports	A **	B †	C	Depth	Weight lb (kg)
1/8, 1/4	6.9 (175)	3.6 (92)	1.7 (43)	3.6 (92)	0.53 (0.24)
<b>Models below have quick-connect fittings for tubing.</b>					
1/4	7.3 (185)	3.6 (92)	1.7 (43)	3.6 (92)	0.50 (0.23)
3/8	7.8 (198)	3.6 (92)	1.7 (43)	3.6 (92)	0.50 (0.23)
4 mm	7.3 (185)	3.6 (92)	1.7 (43)	3.6 (92)	0.50 (0.23)
6 mm	7.3 (185)	3.6 (92)	1.7 (43)	3.6 (92)	0.50 (0.23)
8 mm	7.0 (178)	3.6 (92)	1.7 (43)	3.6 (92)	0.50 (0.23)
10 mm	7.8 (198)	3.6 (92)	1.7 (43)	3.6 (92)	0.50 (0.23)

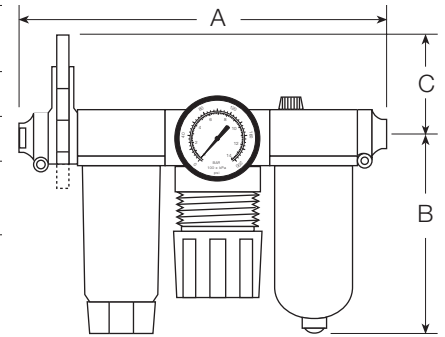

\*\* Without V10 lockout valve deduct 0.6 (15) from dimension A.  
 † Dimension for plastic bowl: metal bowl is 4.3 (109).

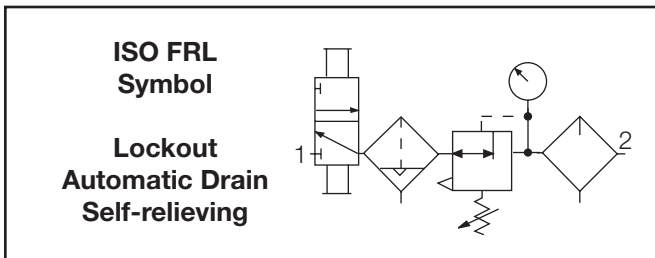

## REPLACEMENT FILTER ELEMENT KITS

Element Type	Kit Number
5-µm polyethylene (Std element).....	KA130-27PE5
5-µm bronze .....	KA130-27E5
20-µm bronze .....	KA130-27E4
40-µm bronze .....	KA130-27E3

## ORDERING INFORMATION

Change the letters in the sample model number below to specify the **FRL** you want.  
 NOTE: For model numbers longer than 15 characters, please consult Master Pneumatic.

# B V F D R L 10 P - 2 X Y G W

<p><b>BOWL TYPE</b></p> <p>Plastic bowls ...Leave Blank              Metal bowls ..... B</p> <p><b>LOCKOUT VALVE</b></p> <p>V10 valve .....V              None ..... Leave Blank</p> <p><b>FILTER DRAIN</b></p> <p>Internal automatic drain .....FD              Manual drain..... F</p> <p><b>REGULATOR TYPE</b></p> <p>Piston type ..... 10              Diaphragm type..... 11</p> <p><b>MOUNTING HOLE LOCATION</b></p> <p>Bottom mount (Standard) ..... Leave Blank              Top mount ..... P</p> <p><b>INLET PORT SIZE</b></p> <p>No inlet and outlet ports .....Leave Blank              Threaded:              1/8 NPTF ..... 1              1/4 NPTF ..... 2              Fittings for Tubing:              1/4.....04              3/8.....06              4 mm.....M4              6 mm.....M6              8 mm.....M8              10 mm.....M10</p>	<p><b>OUTLET PORT SIZE</b></p> <p>Same as inlet port .... Leave Blank              Threaded:              1/8 NPTF ..... 1              1/4 NPTF ..... 2              Fittings for Tubing:              1/4.....04              3/8.....06              4 mm.....M4              6 mm.....M6              8 mm.....M8              10 mm..... M10</p>	<p><b>PORT TYPE</b></p> <p>As specified in <b>INLET PORT</b>... Leave Blank              BSPP threads on both ports ..... W</p> <p><b>OPTIONS</b> (<i>More than one option can be chosen</i>)</p> <p>None ..... Leave Blank              0-160 PSI Gauge ..... G              Plastic Panel Mount Nut ..... P              Metal Panel Mount Nut ..... PN              Hex Plastic mounting nut ..... PE</p> <p><b>OPTIONS</b> (<i>More than one option can be chosen</i>)</p> <p>None ..... Leave Blank              Non-relieving regulator.....A              Sintered bronze filter element:              5-µm rating..... E5              20-µm rating..... E4              40-µm rating..... E3              Adjusting springs:              0-125 psig (0-8.6 bar).....H              0-50 psig (0-3.4 bar)..... L              0-8 psig (0-0.6 bar)..... L8              0-15 psig (0-1.0 bar)..... L15              0-30 psig (0-2.1 bar)..... L30              Tamper-resistant spinning              knob (psig preset) ..... MV(*)              Quick-fill lubricator Q-cap ..... Q              Viton seals ..... V</p>
---	---	--

\*Insert preset pressure.

FRLs

# MINIATURE FRLs

## Filter-Regulator-Lubricators

# FDRL55 and 56 Models

## Port Sizes: 1/8, 1/4

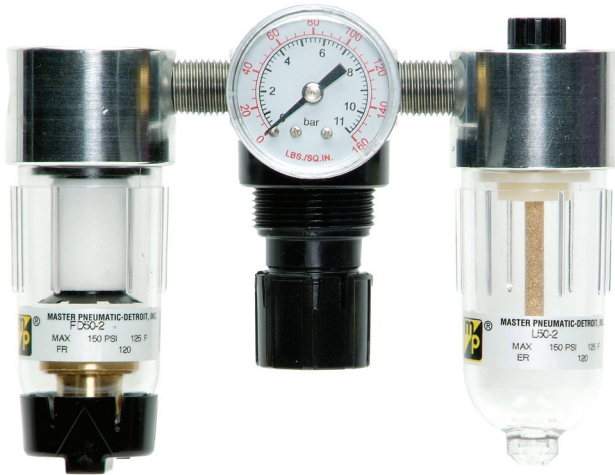

Model Shown: FDRL56-2

- ◆ Individual filter (**FD50**); piston-type regulator (**R55M**) or diaphragm-type (**R56M**); and wick-feed lubricator (**L50**).
- ◆ Inline mounting.
- ◆ 5- $\mu$ m-rated polyethylene filter element; optional sintered bronze elements.
- ◆ High-strength polycarbonate plastic bowls **or** aluminum bowls.
- ◆ Internal automatic filter drain; optional manual drain.
- ◆ Self-relieving regulator; non-relieving optional.
- ◆ Pressure gauge.
- ◆ **NPTF** port threads; optional **BSPP** threads.

## SPECIFICATIONS

### Ambient/Media Temperature:

Plastic bowls: 40° to 125°F (4° to 52°C).

Metal bowls: 40° to 175°F (4° to 79°C).

**Bowls:** 2-Ounce (60-ml) capacity polycarbonate plastic bowls or aluminum bowls.

### Filter Drain:

Internal automatic drain; optional manual drain.

**Filter Element:** 5- $\mu$ m-rated polyethylene; optional 5- $\mu$ m, 20- $\mu$ m, or 40- $\mu$ m sintered bronze.

**Fluid Media:** Compressed air.

**Heads:** Aluminum.

### Inlet Pressure:

15 psig (1 bar) minimum with automatic drain.

Plastic bowls: 150 psig (10 bar) maximum.

Metal bowls: 200 psig (13.7 bar) maximum.

**Oil Adjustment:** Internal; tamper-resistant.

**Outlet Pressure:** Adjustable up to 100 psig (7 bar).

**Pressure Gauge:** 0 to 160 psig (10.3 bar); 1/8 NPT gauge ports front and rear.

**Panel Mounting:** 1-3/16 inch (30 mm) hole required.

**Regulator Dome and Knob:** Acetal.

**Seals:** Nitrile.

## AIR FLOW DATA

See Flow Charts for individual assembly components on preceding pages.



## DIMENSIONS inches (mm)

A	B	C	Depth †	Weight lb (kg)	
Plastic	5.5 (140)	3.6 (92)	0.7 (17)	1.6 (41)	0.76 (0.34)
Metal	5.5 (140)	4.3 (109)	0.7 (17)	1.6 (41)	

† Less gauge.

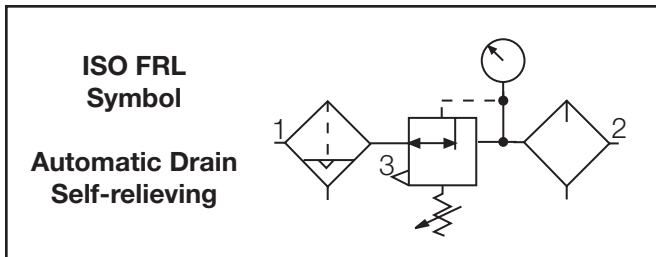
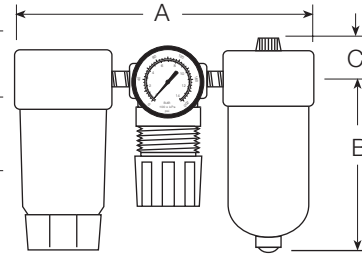

## REPLACEMENT FILTER ELEMENT KITS

Element Type	Kit Number
5- $\mu$ m polyethylene (Std element).....	KA130-27PE5
5- $\mu$ m bronze .....	KA130-27E5
20- $\mu$ m bronze .....	KA130-27E4
40- $\mu$ m bronze .....	KA130-27E3

## ORDERING INFORMATION

Change the letters in the sample model number below to specify the **FRL** you want.

**NOTE:** For model numbers longer than 15 characters, please consult Master Pneumatic.

**B FD RL 55 - 2 Y G W**

**BOWL TYPE**

Plastic bowls ...Leave Blank  
Metal bowls ..... B

**FILTER DRAIN**

Internal automatic drain ..... FD  
Manual drain ..... F

**REGULATOR TYPE**

Piston type ..... 55  
Diaphragm type ..... 56

**PORT SIZE**

1/8 NPTF ..... 1  
1/4 NPTF ..... 2

**PORT TYPE**

NPTF Threads ..... Leave Blank  
BSPP threads ..... W

**OPTIONS (More than one option can be chosen)**

None ..... Leave Blank  
0-160 PSI Gauge ..... G  
Plastic Panel Mount Nut ..... P  
Metal Panel Mount Nut ..... PN  
Hex Plastic mounting nut ..... PE

**OPTIONS (More than one option can be chosen)**

None ..... Leave Blank  
Non-relieving regulator ..... A  
Sintered bronze filter element:

- 5- $\mu$ m rating ..... E5
- 20- $\mu$ m rating ..... E4
- 40- $\mu$ m rating ..... E3

Adjusting springs:

- 0-125 psig (0-8.6 bar) ..... H
- 0-50 psig (0-3.4 bar) ..... L
- 0-8 psig (0-0.6 bar) ..... L8
- 0-15 psig (0-1.0 bar) ..... L15
- 0-30 psig (0-2.1 bar) ..... L30

Tamper-resistant spinning knob (psig preset) ..... MV(\*)  
Quick-fill lubricator Q-cap ..... Q  
Tapped modified head to ..... T  
to allow 50-01 bracket assy.  
Both on Filter and Lubricator.  
Viton seals ..... V

\*Insert preset pressure.

# GUARDSMAN Modular FRLs Filter-Regulator-Lubricators

# MVFDRL60D Models Port Sizes: 1/4, 3/8, 1/2



Model Shown: MVFDRL60D-3G

## SPECIFICATIONS

### Ambient/Media Temperature:

40° to 125°F (4° to 52°C). With metal bowls but no lockout valve: 40° to 175°F (4° to 79°C).

**Bowls:** 4-Ounce (120-ml) capacity zinc bowls or polycarbonate plastic bowls with zinc shatterguard.

### Filter Drain:

Internal automatic drain; optional manual drain.

**Filter Element:** 5- $\mu$ m-rated polyethylene; optional 5- $\mu$ m, 20- $\mu$ m, or 40- $\mu$ m sintered bronze.

**Fluid Media:** Compressed air.

**Heads:** Zinc.

### Inlet Pressure:

15 psig (1 bar) minimum with automatic drain.  
150 psig (10 bar) maximum. With metal bowls but no lockout valve: 200 psig (13.7 bar) maximum.

**Oil Adjustment:** External; tamper-resistant.

**Outlet Pressure:** Adjustable up to 100 psig (7 bar).

**Pressure Gauge:** 0 to 200 psig (14 bar); 1/4 NPT gauge ports front and rear.

**Panel Mounting:** 1-9/16 inch (40 mm) hole required.

**Regulator Dome and Knob:** Acetal. Optional metal regulator dome.

**Seals:** Nitrile.

**Sight Dome:** Clear nylon.

- ◆ Individual filter (**FD60**); piston-type regulator (**R60**); sight-feed lubricator (**L60D**); lockout valve (**V35**).
- ◆ Modular or inline mounting.
- ◆ 5- $\mu$ m-rated polyethylene filter element; optional sintered bronze elements.
- ◆ High-strength zinc bowls **or** polycarbonate plastic bowls with shatterguard.
- ◆ Internal automatic filter drain; optional manual drain.
- ◆ Self-relieving regulator; non-relieving optional.
- ◆ Pressure gauge.
- ◆ NPTF port threads; optional **SAE** or **BSPP** threads.

## AIR FLOW DATA

See Flow Charts for individual assembly components on preceding pages.

## DIMENSIONS inches (mm)

A *	B	C	Depth	Weight lb (kg)
12.3 (312)	4.6 (117)	1.8 (46)	2.8 (71)	3.75 (1.70)

\*Without V35 lockout valve deduct 3.8 (97) from dimension A.

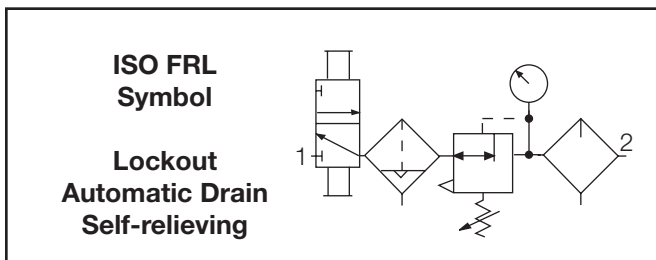
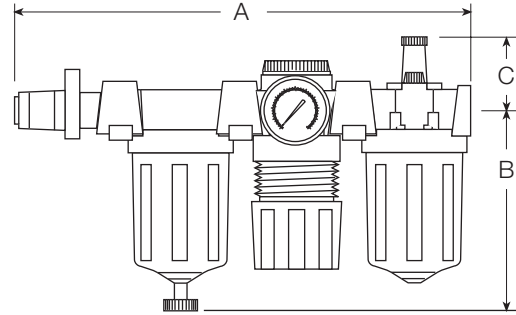

## REPLACEMENT FILTER ELEMENT KITS

Element Type	Kit Number
5- $\mu$ m polyethylene (Std element).....	KA60F-03
5- $\mu$ m bronze .....	KA60F-03E5
20- $\mu$ m bronze .....	KA60F-03E4
40- $\mu$ m bronze .....	KA60F-03E3

## ORDERING INFORMATION

Change the letters in the sample model number below to specify the FRL you want.  
NOTE: For model numbers longer than 15 characters, please consult Master Pneumatic.

**B M V FD RL 60D - 2 Y NG W**

**BOWL TYPE**

Plastic bowl.....Leave Blank  
Metal bowl..... B

**ASSEMBLY**

Modular.....M  
Pipe nipple .....Leave Blank

**LOCKOUT VALVE**

V35 valve ..... V  
No valve ..... Leave Blank

**FILTER DRAIN**

Internal automatic drain .....FD  
Manual drain..... F

**REGULATOR DOME**

Acetal .....60D  
Metal .....65D

**PORT SIZE**

1/4 NPTF.....2  
3/8 NPTF.....3  
1/2 NPTF.....4  
9/16-18 UNF SAE .....S6

**PORT TYPE**

NPTF Threads ..... Leave Blank  
BSP threads ..... W

**GAUGE**

Gauge .....Leave Blank  
No gauge ..... NG

**OPTIONS** (*More than one option can be chosen*)

None .....Leave Blank  
Non-relieving regulator.....A  
Sintered bronze filter element:  
5- $\mu$ m rating..... E5  
20- $\mu$ m rating..... E4  
40- $\mu$ m rating..... E3  
Adjusting springs:  
0-150 psig (0-10 bar).....H  
0-50 psig (0-3.4 bar)..... L  
Quick-fill lubricator Q-cap .....Q

# GUARDSMAN II Modular FRLs Filter-Regulator-Lubricators

# BMVFDRL70D Models Port Sizes: 1/4, 3/8, 1/2



Model Shown: BMVFDRL70D-4

## SPECIFICATIONS

### Ambient/Media Temperature:

40° to 125°F (4° to 52°C) with V35 lockout valve.  
40° to 175°F (4° to 79°C) with R75 regulator and without  
V35 lockout valve.

**Bowls:** 6-Ounce (180-ml) capacity aluminum with clear  
nylon sight glass. Optional 10-ounce (300-ml) extended  
bowls. Bowls can be rotated for easy readability.

**Bowl Rings:** Nylon.

### Filter Drain:

Internal automatic drain; optional manual drain.

**Filter Element:** 5- $\mu$ m-rated polyethylene; optional  
5- $\mu$ m or 40- $\mu$ m sintered bronze.

**Fluid Media:** Compressed air.

**Heads:** Zinc.

### Inlet Pressure:

15 psig (1 bar) minimum with automatic drain.  
150 psig (10 bar) maximum.  
Without lockout valve: 200 psig (13.7 bar) maximum.

**Oil Adjustment:** External; tamper-resistant.

**Outlet Pressure:** Adjustable up to 100 psig (7 bar).

**Pressure Gauge:** 0 to 200 psig (14 bar); 1/4 NPT gauge  
ports front and rear.

**Panel Mounting:** Nut included only with R75 lubricator;  
1-9/16 inch (40 mm) hole required.

**Seals:** Nitrile.

**Sight Dome:** Clear nylon.

- ◆ Individual filter (**BFD70**); piston-type regulator (**R60**); sight-feed lubricator (**BL70D**); lockout valve (**V35**)
- ◆ 5- $\mu$ m-rated polyethylene filter element; optional sintered bronze elements.
- ◆ Aluminum bowls with clear nylon sight glass. Bowls can be rotated for easy readability.
- ◆ Optional extended bowls provide greater filter sump and lubricator capacities.
- ◆ Internal automatic filter drain; optional manual drain.
- ◆ Self-relieving regulator; non-relieving optional.
- ◆ **R75** regulator optional.
- ◆ Pressure gauge.
- ◆ **NPTF** port threads; optional **SAE** or **BSPP** threads.

## AIR FLOW DATA

See Flow Charts for individual assembly  
components on preceding pages.

## DIMENSIONS inches (mm)

Bowl	A *	B	C	Depth	Weight lb (kg)
Standard	12.3 (312)	5.9 (151)	3.3 (83)	2.4 (60)	5.00 (2.27)
Extended	12.3 (312)	8.9 (227)	3.3 (83)	2.4 (60)	5.50 (2.50)

\* Without V35 lockout valve deduct 3.8 (97) from dimension A.

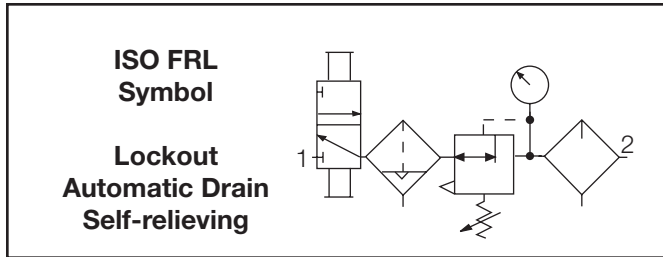
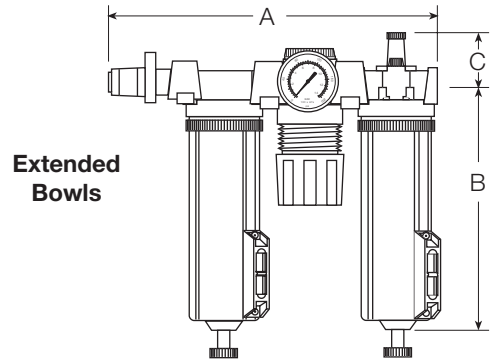
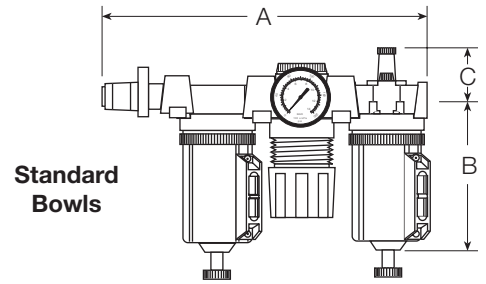

## REPLACEMENT FILTER ELEMENT KITS

Element Type	Kit Number
5- $\mu$ m polyethylene (Std element).....	KA60F-03PE5
5- $\mu$ m bronze .....	KA60F-03E5
40- $\mu$ m bronze .....	KA60F-03E3

## ORDERING INFORMATION

Change the letters in the sample model number below to specify the **FR L** you want.  
**NOTE:** For model numbers longer than 15 characters, please consult Master Pneumatic.

**B M V FD RL 70 D - 2 Y NG W**

### LOCKOUT VALVE

No valve .....Leave Blank  
 V35 valve ..... V

### FILTER DRAIN

Internal automatic drain .....FD  
 Manual drain.....F

### REGULATOR SERIES

R60 with plastic dome..... 70  
 R75 with metal dome and  
 panel mounting nut..... 75

### BOWL SIZE

Standard 6-ounce bowls .....D  
 Extended 10-ounce bowls..... DH

### PORT TYPE

NPTF Threads ..... Leave Blank  
 BSPP threads ..... W

### GAUGE

0-200 psig Gauge .....Leave Blank  
 No gauge ..... NG

### OPTIONS (More than one option can be chosen)

None .....Leave Blank  
 Non-relieving regulator..... A  
 Sintered bronze filter element:  
     5- $\mu$ m rating..... E5  
     40- $\mu$ m rating..... E3  
 Adjusting springs:  
     0-150 psig (0-10 bar).....H  
     0-50 psig (0-3.4 bar)..... L  
 Quick-fill lubricator Q-cap .....Q  
 Tee handle, R75 regulator only..... T

### PORT SIZE

1/4 NPTF.....2  
 3/8 NPTF.....3  
 1/2 NPTF.....4  
 9/16-18 UNF SAE .....S6

# Full-Size VANGUARD Modular FRLs Filter-Regulator-Lubricators

## MVFDRL108D Models Port Sizes: 1/4, 3/8, 1/2, 3/4



Model Shown: MVFDRL108D-4

### SPECIFICATIONS

#### Ambient/Media Temperature:

Plastic bowls: 40° to 125°F (4° to 52°C).

Metal bowls with V35 lockout valve:

40° to 150°F (4° to 66°C).

Metal bowls without V35 lockout valve:

40° to 175°F (4° to 79°C).

**Bowls:** 8-Ounce (240-ml) capacity zinc bowls with clear nylon sight glass or polycarbonate plastic bowls with steel shatterguard. Optional 20-ounce (600-ml) extended metal lubricator bowl.

**Bowl Rings:** Aluminum.

#### Filter Drain:

Internal automatic drain; optional manual drain or Warrior electronic drain.

**Filter Element:** 5- $\mu$ m-rated polyethylene; optional 5- $\mu$ m, 20- $\mu$ m, or 40- $\mu$ m sintered bronze.

**Fluid Media:** Compressed air.

**Heads:** Zinc.

#### Inlet Pressure:

15 psig (1 bar) minimum with automatic drain.  
125 psig (8.6 bar) maximum. With metal bowls but no lockout valve: 200 psig (13.7 bar) maximum.

**Oil Adjustment:** External; tamper-resistant.

**Outlet Pressure:** Adjustable up to 125 psig (8.6 bar).

**Pressure Adjustment Locking Key:** Removable.

**Pressure Gauge:** 0 to 200 psig (14 bar); 1/4 NPT gauge ports front and rear.

**Regulator:** Nylon dome; acetal knob.

**Seals:** Nitrile.

**Sight Dome:** Clear nylon.

- ◆ Individual filter (FD100); diaphragm-type regulator (R100); sight-feed lubricator (L28D); lockout valve (V35).
- ◆ Modular or inline mounting.
- ◆ 5- $\mu$ m-rated polyethylene filter element; optional sintered bronze elements.
- ◆ Zinc bowls with clear nylon sight glass **or** polycarbonate plastic bowls with steel shatterguard.
- ◆ Internal automatic filter drain; optional manual drain or Warrior electronic drain.
- ◆ Self-relieving regulator; non-relieving optional.
- ◆ Pressure gauge.
- ◆ NPTF port threads; optional SAE or BSPP threads.

### AIR FLOW DATA

See Flow Charts for individual assembly components on preceding pages.

## DIMENSIONS inches (mm)

Bowl	A **	B	C	Depth †	Weight † lb (kg)
8-Oz Metal	13.9 (353)	6.4 (163)	1.3 (33)	2.8 (71)	7.06 (3.20)
8-Oz Plastic	13.9 (353)	5.8 (147)	1.3 (33)	2.8 (71)	7.06 (3.20)
20-Oz Metal	13.9 (353)	9.8 (249)	1.3 (33)	2.8 (71)	7.45 (3.39)

\*\* Without V35 lockout valve deduct 3.8 (97) from dimension A.

† Less gauge.

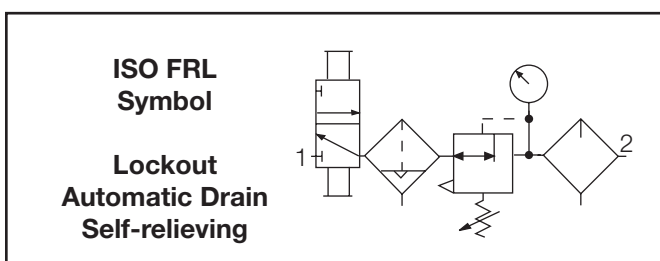
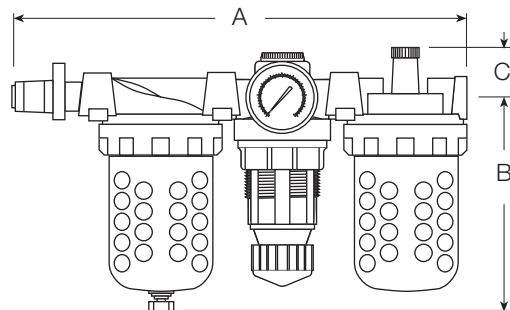

## REPLACEMENT FILTER ELEMENT KITS

Element Type	Kit Number
5-µm polyethylene (Std element).....	KA103-3PE
5-µm bronze .....	KA103-3PE5
20-µm bronze .....	KA103-3PE4
40-µm bronze .....	KA103-3PE3

## ORDERING INFORMATION

Change the letters in the sample model number below to specify the **FRL** you want.

**NOTE:** For model numbers longer than 15 characters, please consult Master Pneumatic.

B M V FD RL 108D - 2 Y W

**BOWL TYPE**

Metal bowls ..... B

Plastic bowls ... Leave Blank

**LOCKOUT VALVE**

No valve ..... Leave Blank

V35 valve ..... V

**FILTER DRAIN**

Internal automatic drain ..... FD

Manual drain ..... F

Warrior electronic drain ..... F2A

**BOWL SIZE**

Standard 8-ounce bowls ..... 108D

8-Ounce filter bowl &  
20-ounce lubricator bowl  
(metal bowls only) ..... 108DH

**PORT SIZE**

1/4 NPTF ..... 2

3/8 NPTF ..... 3

1/2 NPTF ..... 4

3/4 NPTF ..... 6X

9/16-18 UNF SAE ..... S6

3/4-16 UNF SAE ..... S8

7/8-14 UNF SAE ..... S10

**PORT TYPE**

NPTF Threads ..... Leave Blank

BSPP threads ..... W

**OPTIONS** (*More than one option can be chosen*)

None ..... Leave Blank

Non-relieving regulator ..... A

Sintered bronze filter element:

5-µm rating ..... E5

20-µm rating ..... E4

40-µm rating ..... E3

Adjusting springs:

0-175 psig (0-12 bar) ..... H \*\*

0-50 psig (0-3.4 bar) ..... L

Remove adjusting key ..... JJ

Metal Dome ..... MD

Limit maximum psig setting .... M\*

Delete gauge ..... NG

Regulator tee handle ..... T

Quick-fill lubricator Q-cap ..... Q

\* Insert maximum limited pressure.

\*\* H option spring includes metal dome.

**FRLs**

Master Pneumatic-Detroit, Inc.

263

# Full-Size VANGUARD Modular FRLs Filter-Regulator-Lubricators

# MVFDRL108W Models Port Sizes: 1/4, 3/8, 1/2, 3/4



Model Shown: MVFDRL108W-4

## SPECIFICATIONS

### Ambient/Media Temperature:

Plastic bowls: 40° to 125°F (4° to 52°C).

Metal bowls with V35 lockout valve:

40° to 150°F (4° to 66°C).

Metal bowls without V35 lockout valve:

40° to 175°F (4° to 79°C).

**Bowls:** 8-Ounce (240-ml) capacity zinc bowls with clear nylon sight glass or polycarbonate plastic bowls with steel shatterguard. Optional 20-ounce (600-ml) extended lubricator bowl.

**Bowl Rings:** Aluminum.

### Filter Drain:

Internal automatic drain; optional manual drain or Warrior electronic drain.

**Filter Element:** 5- $\mu$ m-rated polyethylene; optional 5- $\mu$ m, 20- $\mu$ m, or 40- $\mu$ m sintered bronze.

Fluid Media: Compressed air.

**Heads:** Zinc.

### Inlet Pressure:

15 psig (1 bar) minimum with automatic drain.

125 psig (8.6 bar) maximum. With metal bowls but no lockout valve: 200 psig (13.7 bar) maximum.

**Oil Adjustment:** External; tamper-resistant.

**Outlet Pressure:** Adjustable up to 125 psig (8.6 bar).

**Pressure Adjustment Locking Key:** Removable.

**Pressure Gauge:** 0 to 200 psig (14 bar); 1/4 NPT gauge ports front and rear.

**Regulator:** Nylon dome; acetal knob.

**Seals:** Nitrile.

- ◆ Individual filter (**FD100**); diaphragm-type regulator (**R100**); wick-feed lubricator (**L28W**); lockout valve (**V35**).
- ◆ Modular or inline mounting.
- ◆ 5- $\mu$ m-rated polyethylene filter element; optional sintered bronze elements.
- ◆ Zinc bowls with clear nylon sight glass **or** polycarbonate plastic bowls with steel shatterguard.
- ◆ Internal automatic filter drain; optional manual drain or Warrior electronic drain.
- ◆ Self-relieving regulator; non-relieving optional.
- ◆ Pressure gauge.
- ◆ **NPTF** port threads; optional **SAE** or **BSPP** threads.

## AIR FLOW DATA

See Flow Charts for individual assembly components on preceding pages.



## DIMENSIONS inches (mm)

Bowl	A **	B	C	Depth †	Weight † lb (kg)
8-Oz Metal	13.9 (353)	6.4 (163)	1.3 (33)	2.8 (71)	7.06 (3.20)
8-Oz Plastic	13.9 (353)	5.8 (147)	1.3 (33)	2.8 (71)	7.06 (3.20)
20-Oz Metal	13.9 (353)	9.8 (249)	1.3 (33)	2.8 (71)	7.45 (3.39)

\*\* Without V35 lockout valve deduct 3.8 (97) from dimension A.  
† Less gauge.

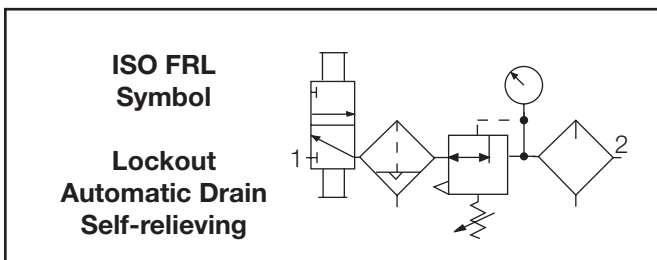
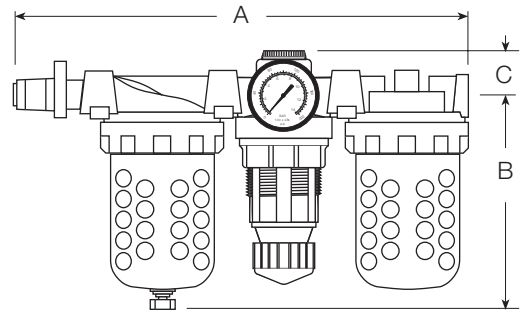

## REPLACEMENT FILTER ELEMENT KITS

Element Type	Kit Number
5-µm polyethylene (Std element).....	KA103-3PE
5-µm bronze .....	KA103-3PE5
20-µm bronze .....	KA103-3PE4
40-µm bronze .....	KA103-3PE3

## ORDERING INFORMATION

Change the letters in the sample model number below to specify the **FRL** you want.

**NOTE:** For model numbers longer than 15 characters, please consult Master Pneumatic.

# B M V FD RL 108W - 2 Y W

### BOWL TYPE

Metal bowls.....B  
Plastic bowls ...Leave Blank

### LOCKOUT VALVE

No valve .....Leave Blank  
V35 valve ..... V

### FILTER DRAIN

Internal automatic drain .....FD  
Manual drain.....F  
Warrior electronic drain.....F2A

### BOWL SIZE

Standard 8-ounce bowls ..... 108W  
8-Ounce filter bowl &  
20-ounce lubricator bowl  
(metal bowls only) ..... 108WH

### PORT SIZE

1/4 NPTF.....2  
3/8 NPTF.....3  
1/2 NPTF.....4  
3/4 NPTF.....6X  
9/16-18 UNF SAE .....S6  
3/4-16 UNF SAE .....S8  
7/8-14 UNF SAE .....S10

### PORT TYPE

NPTF Threads ..... Leave Blank  
BSPP threads ..... W

### OPTIONS (More than one option can be chosen)

None ..... Leave Blank  
Non-relieving regulator.....A  
Sintered bronze filter element:

5-µm rating .....E5  
20-µm rating .....E4  
40-µm rating .....E3

### Adjusting springs:

0-175 psig (0-12 bar) .....H \*\*  
0-50 psig (0-3.4 bar).....L

Remove adjusting key .....JJ  
Metal Dome ..... MD  
Limit maximum psig setting .... M\*  
Delete gauge ..... NG  
Regulator tee handle .....T  
Quick-fill lubricator Q-cap .....Q

\* Insert maximum limited pressure.

\*\* H option spring includes metal dome.

# Full-Size SERIES 380 FRLs Filter-Regulator-Lubricators

# AAMV1A1B1A1 Models Port Sizes: 3/8, 1/2, 3/4



Model Shown: AAMV1A1BJ16

### Available Color Caps



Yellow  
(optional)

Red  
(optional)

Blue  
(optional)

Grey  
(standard)

## SPECIFICATIONS

### Ambient/Media Temperature:

Metal bowls: 40° to 175°F (4° to 79°C).  
Plastic bowls: 40° to 125°F (4° to 52°C).

Bowls: 9-Ounce (270-ml) capacity aluminum bowls with clear nylon sight glass or polycarbonate plastic bowls with steel shatterguard. Optional 15-ounce (450-ml) extended aluminum lubricator bowl with two clear nylon sight glasses.

**Bowl Rings:** Nylon.

**Cap Color:** Accent grey. Yellow, red, and blue optional.

**Filter Drain:** Internal automatic drain; optional manual drain or Warrior electronic drain.

**Filter Element:** 5- $\mu$ m-rated polyethylene; optional 40- $\mu$ m element.

**Fluid Media:** Compressed air.

**Heads:** Zinc.

### Inlet Pressure:

15 psig (1 bar) minimum with automatic drain.  
Metal bowls: 200 psig (13.7 bar) maximum.  
Plastic bowls: 150 psig (10 bar) maximum.

**Oil Adjustment:** External; tamper-resistant.

**Outlet Pressure:** Adjustable up to 125 psig (8.6 bar).

**Pressure Adjustment Locking Key:** Removable.

**Pressure Gauge:** 0 to 200 psig (14 bar); 1/4 NPT gauge ports front and rear.

**Seals:** Nitrile.

**Sight Dome:** Clear nylon.

- ◆ Individual filter (**FD380**); regulator (**R380**); lubricator (**L380D**); lockout valve (**V380**).
- ◆ Modular or inline mounting.
- ◆ 5- $\mu$ m-rated polyethylene filter element; optional 40- $\mu$ m element.
- ◆ Aluminum bowls with clear nylon sight glass **or** polycarbonate plastic bowls with steel shatterguard.
- ◆ Internal automatic filter drain; optional manual drain or Warrior electronic drain.
- ◆ Optional extended aluminum lubricator bowl with sight glasses.
- ◆ Self-relieving diaphragm-type regulator; non-relieving optional.
- ◆ Pressure gauge; two gauge ports.
- ◆ NPTF port threads; optional SAE or BSPP threads.

### AIR FLOW DATA

See Flow Charts for individual assembly components on preceding pages.

## DIMENSIONS inches (mm)

Bowls	A *	B **	C	Depth †	Weight † lb (kg)
9-Oz Plastic	13.4 (340)	7.7 (195)	2.2 (56)	2.9 (73)	6.94 (3.15)
9-Oz Metal	13.4 (340)	7.6 (193)	2.2 (56)	3.1 (79)	6.94 (3.15)
Ext Metal	13.4 (340)	10.6 (269)	2.2 (56)	3.1 (79)	7.13 (3.24)

\* Without V380 lockout valve deduct 2.5 (64) from dimension A.

\*\* Bowl removal clearance: For 9-ounce bowls add 3.4 (86).  
For extended bowl add 6.1 (155).

† Less gauge.

## REPLACEMENT FILTER ELEMENT KITS

Element Type	Kit Number
5-µm (Std element)	A115-106PE5
40-µm bronze	A115-106PE3

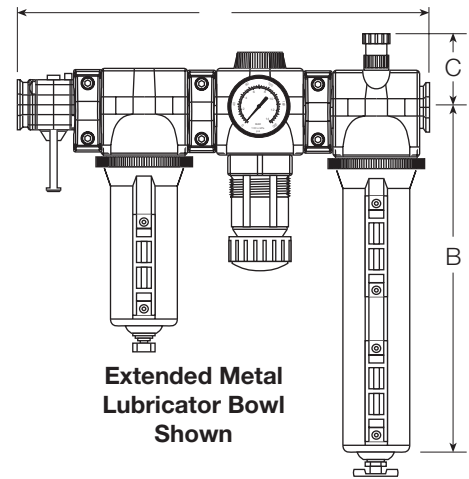
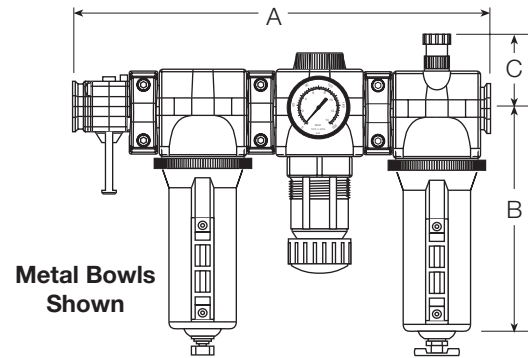
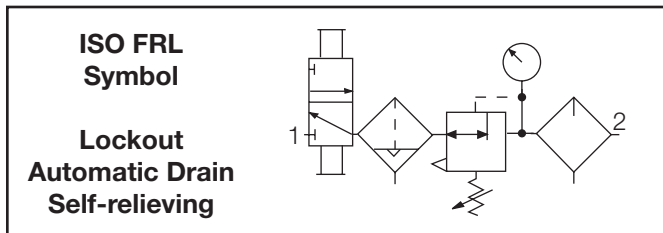

## ORDERING INFORMATION

Change the letters in the sample model number below to specify the **FRL** you want.  
To order with some of the other available options, see Ordering Information on page 291.

**A A M V 1 A 1 B 1 A 1 3**

### CAP COLOR

Accent Grey (Std) .... A  
MP Yellow..... B  
Red ..... C  
Mid Blue..... D

### BOWL TYPE

Two 9-ounce plastic ..... A  
Two 9-ounce metal..... B  
9-Ounce metal on filter  
and 15-ounce metal  
on lubricator ..... D

### LOCKOUT VALVE

No valve ..... Leave Blank  
V380 valve ..... V

### FILTER MODEL

F380 (5-µm element) ..... 1  
F380-E3 (40-µm element).... 2

### REGULATOR MODEL

R380 (0-125 psig)..... 1  
R380-H (0-175 psig and ..... 5\*  
metal dome)  
R380-L (0-50 psig) ..... 7

### PORT SIZE

3/8 NPTF..... 3  
1/2 NPTF..... 4  
3/4 NPTF..... 6  
3/8 BSPP ..... C  
1/2 BSPP ..... D  
3/4 BSPP ..... E  
3/4-16 UNF SAE ..... F  
7/8-14 UNF SAE ..... G

### GAUGES

None ..... 0  
200-BDD (0-200 psig) ..... 1  
60BDD (0-60 psig)..... 2

### MOUNTING OPTIONS

No end ports ..... A  
Mounting brackets only ..... J  
Female ports and  
mounting brackets..... K

### LUBRICATOR MODEL

L380D ..... B  
L380D-Q (with Q-cap) ..... C

\* H option spring includes metal dome.

# High-Capacity VANGUARD FRLs Filter-Regulator-Lubricators

# FDRL180 Models Port Sizes: 3/4, 1



Model Shown: FDRL180-6

## SPECIFICATIONS

### Ambient/Media Temperature:

Plastic bowls: 40° to 125°F (4° to 52°C).

Metal bowls with V35 lockout valve:

40° to 150°F (4° to 66°C).

Metal bowls without V35 lockout valve:

40° to 175°F (4° to 79°C).

**Bowls:** 16-Ounce (480-ml) capacity aluminum bowls with sight glass or polycarbonate plastic bowls with steel shatterguard.

**Bowl Rings:** Aluminum.

### Filter Drain:

Internal automatic drain; optional manual drain, external Hydro-Jector drain, or Warrior electronic drain.

**Filter Element:** 5- $\mu$ m-rated polyethylene; optional 5- $\mu$ m, 20- $\mu$ m, or 40- $\mu$ m sintered bronze.

**Fluid Media:** Compressed air.

**Heads:** Aluminum.

### Inlet Pressure:

15 psig (1 bar) minimum with automatic drain.

Plastic bowls: 150 psig (10 bar) maximum.

Metal bowls: 200 psig (14 bar) maximum.

**Oil Adjustment:** External; tamper-resistant.

**Outlet Pressure:** Adjustable up to 100 psig (7 bar).

**Pressure Adjustment Locking Key:** Removable.

**Pressure Gauge:** 0 to 200 psig (14 bar); 1/4 NPT gauge ports front and rear.

**Seals:** Nitrile.

- ◆ Individual filter (**FD100**); piston-type regulator (**R180M**); wick-feed lubricator (**L100**)
- ◆ Inline mounting.
- ◆ 5- $\mu$ m-rated polyethylene filter element; optional sintered bronze elements.
- ◆ Metal bowls with clear nylon sight glass or polycarbonate plastic bowls with steel shatterguard.
- ◆ Internal automatic filter drain. Optional manual drain, external Hydro-Jector drain, or Warrior electronic drain.
- ◆ Self-relieving regulator; non-relieving optional.
- ◆ Pressure gauge
- ◆ NPTF port threads; optional **BSPP** threads.

## AIR FLOW DATA

See Flow Charts for individual assembly components on preceding pages.

**DIMENSIONS** inches (mm)

A	B	C	Depth	Weight lb (kg)
15.8 (401)	8.0 (204)	1.2 (31)	4.3 (108)	8.00 (3.64)

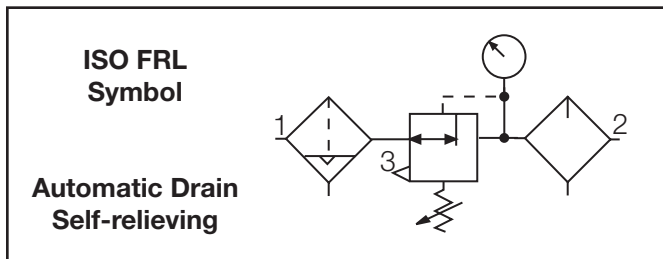
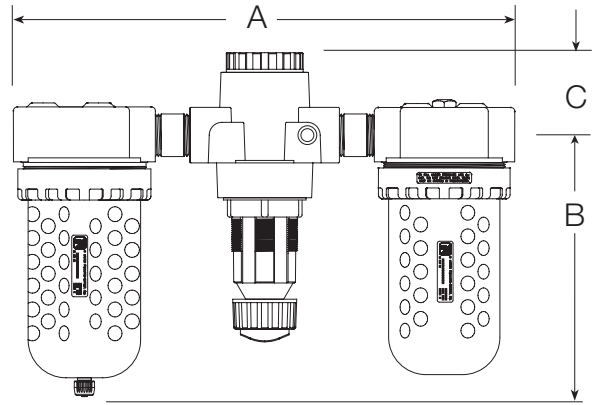

**REPLACEMENT FILTER ELEMENT KITS**

Element Type	Kit Number
5-µm polyethylene (Std element).....	KA109-3PE
5-µm bronze .....	KA109-03E5
20-µm bronze .....	KA109-03E4
40-µm bronze .....	KA109-03E3

**ORDERING INFORMATION**

Change the letters in the sample model number below to specify the **FRL** you want.  
**NOTE:** For model numbers longer than 15 characters, please consult Master Pneumatic.

**B FD RL 180 - 6 Y W**

**BOWL TYPE**

Metal bowls ..... B  
 Plastic bowls .. Leave Blank

**FILTER DRAIN**

Internal automatic drain    FD  
 Manual drain..... F  
 External Hydro-Jector drain FE  
 Warrior electronic drain    F2A

**PORT SIZE**

3/4 NPTF.....6  
 1 NPTF.....8

**PORT TYPE**

NPTF Threads ..... Leave Blank  
 BSPP threads ..... W

**OPTIONS** (*More than one option can be chosen*)

None ..... Leave Blank  
 Non-relieving regulator ..... A  
 Sintered bronze filter element:  
   5-µm rating ..... E5  
   20-µm rating ..... E4  
   40-µm rating ..... E3

Adjusting springs:  
   0-175 psig (0-12 bar) ..... H \*\*  
   0-50 psig (0-3.4 bar) ..... L  
 Remove adjusting key ..... JJ  
 Delete bowl drain; 1/4 NPT female port instead ..... LDC  
 Metal Dome ..... MD  
 Limit maximum psig setting .... M\*  
 Delete gauge ..... NG  
 Regulator tee handle ..... T  
 Quick-fill lubricator Q-cap ..... Q

\* Insert maximum limited ressure.  
 \*\* H option spring includes metal dome.

**FRLs**

# High-Capacity VANGUARD FRLs Filter-Regulator-Lubricators

# FDRL189D Models Port Sizes: 3/4, 1



Model Shown: FDRL189D-8

- ◆ Individual filter (**FD100**); piston-type regulator (**R180M**); sight feed design lubricator (**L29D**).
- ◆ Inline mounting.
- ◆ 5- $\mu$ m-rated polyethylene filter element; optional sintered bronze elements.
- ◆ Metal bowls with clear nylon sight glass **or** polycarbonate plastic bowls with steel shatterguard.
- ◆ Internal automatic filter drain. Optional manual drain, external Hydro-Jector drain, or Warrior electronic drain.
- ◆ Self-relieving regulator; non-relieving optional.
- ◆ Pressure gauge.
- ◆ **NPTF** port threads; optional *BSPP* threads.

## SPECIFICATIONS

### Ambient/Media Temperature:

Plastic bowls: 40° to 125°F (4° to 52°C).

Metal bowls: 40° to 175°F (4° to 79°C).

**Bowls:** 16-Ounce (480-ml) capacity aluminum bowls with sight glass or polycarbonate plastic bowls with steel shatterguard.

**Bowl Rings:** Aluminum.

### Filter Drain:

Internal automatic drain; optional manual drain, external Hydro-Jector drain, or Warrior electronic drain.

**Filter Element:** 5- $\mu$ m-rated polyethylene; optional 5- $\mu$ m, 20- $\mu$ m, or 40- $\mu$ m sintered bronze.

**Fluid Media:** Compressed air.

**Heads:** Aluminum.

### Inlet Pressure:

15 psig (1 bar) minimum with automatic drain.

Plastic bowls: 150 psig (10 bar) maximum.

Metal bowls: 200 psig (14 bar) maximum.

**Oil Adjustment:** External; tamper-resistant.

**Outlet Pressure:** Adjustable up to 100 psig (7 bar).

**Pressure Adjustment Locking Key:** Removable.

**Pressure Gauge:** 0 to 200 psig (14 bar); 1/4 NPT gauge ports front and rear.

**Seals:** Nitrile.

## AIR FLOW DATA

See Flow Charts for individual assembly components on preceding pages.

**DIMENSIONS** inches (mm)

A	B	C	Depth	Weight lb (kg)
15.8 (401)	8.0 (204)	1.4 (37)	4.3 (108)	8.00 (3.64)

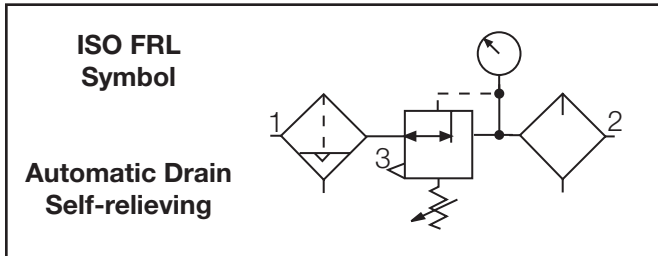
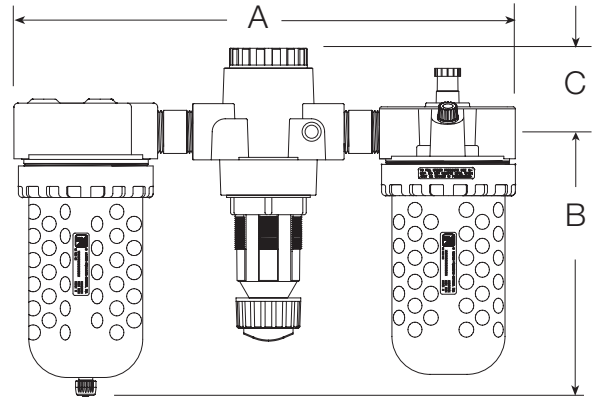

**REPLACEMENT FILTER ELEMENT KITS**

Element Type	Kit Number
5-µm polyethylene (Std element).....	KA109-3PE
5-µm bronze .....	KA109-03E5
20-µm bronze .....	KA109-03E4
40-µm bronze .....	KA109-03E3

**ORDERING INFORMATION**

Change the letters in the sample model number below to specify the **FRL** you want.  
**NOTE:** For model numbers longer than 15 characters, please consult Master Pneumatic.

**B FD RL189D - 6 Y W**

**BOWL TYPE**

Metal bowls..... B  
 Plastic bowls..... Leave Blank

**FILTER DRAIN**

Internal automatic drain .....FD  
 Manual drain.....F  
 External Hydro-Jector drain .....FE  
 Warrior electronic drain .....F2A

**PORT SIZE**

3/4 NPTF.....6  
 1 NPTF.....8

**PORT TYPE**

NPTF Threads ..... Leave Blank  
 BSPP threads ..... W

**OPTIONS** (*More than one option can be chosen*)

None ..... Leave Blank  
 Non-relieving regulator.....A  
 Sintered bronze filter element:  
     5-µm rating.....E5  
     20-µm rating.....E4  
     40-µm rating.....E3  
 Adjusting springs:  
     0-150 psig (0-10 bar).....H \*\*  
     0-50 psig (0-3.4 bar).....L  
 Remove adjusting key .....JJ  
 Delete bowl drain: 1/4 NPT  
     female port instead ..... LDC  
 Metal dome ..... MD  
 Limit maximum psig setting .... M\*  
 Delete gauge ..... NG  
 Regulator tee handle .....T  
 Quick-fill lubricator Q-cap ..... Q

\* Insert maximum limited pressure.  
 \*\* H option spring includes metal dome.

**FRLs**

# High-Capacity VANGUARD FRLs Filter-Regulator-Lubricators

# BFDRL289D Models Port Sizes: 1-1/4, 1-1/2



Model Shown: BFDRL289D-12

- ◆ Individual filter (**BFD200**); piston-type regulator (**R180**); sight-feed lubricator (**BL29D**).
- ◆ Inline mounting.
- ◆ 40- $\mu$ m-rated sintered bronze filter element; optional 5- $\mu$ m sintered bronze element.
- ◆ Aluminum bowls with clear nylon sight glass. Optional extended lubricator bowl.
- ◆ Internal automatic filter drain. Optional manual drain, external Hydro-Jector drain, or Warrior electronic drain.
- ◆ Self-relieving regulator; non-relieving optional.
- ◆ Pressure gauge.
- ◆ **NPTF** port threads; optional **BSPP** threads.

## SPECIFICATIONS

### Ambient/Media Temperature:

40° to 175°F (4° to 79°C).

**Bowls:** 35-Ounce (1 liter) capacity aluminum bowls with clear nylon sight glass. Optional 62-ounce (1830-ml) capacity extended lubricator bowl with two sight glasses.

**Bowl Rings:** Aluminum.

### Filter Drain:

Internal automatic drain. Optional manual drain, external Hydro-Jector drain, or Warrior electronic drain.

**Filter Element:** 40- $\mu$ m-rated sintered bronze; optional 5- $\mu$ m sintered bronze.

**Fluid Media:** Compressed air.

**Heads:** Aluminum.

### Inlet Pressure:

15 psig (1 bar) minimum with automatic drain.  
200 psig (14 bar) maximum.

**Oil Adjustment:** External; tamper-resistant.

**Outlet Pressure:** Adjustable up to 100 psig (7 bar).

**Pressure Adjustment Locking Key:** Removable.

**Pressure Gauge:** 0 to 200 psig (14 bar); 1/4 NPT gauge ports front and rear.

**Regulator:** Nylon dome; acetal knob. Aluminum dome with optional 0-150 psig spring.

**Seals:** Nitrile.

**Sight Dome:** Clear nylon.

## AIR FLOW DATA

See Flow Charts for individual assembly components on preceding pages.



**DIMENSIONS** inches (mm)

A	B	C	Depth	Weight lb (kg)
15.8 (401)	10.6 (268)	2.1 (54)	4.3 (108)	8.00 (3.64)

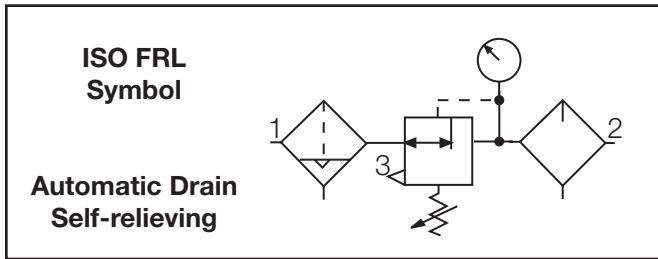
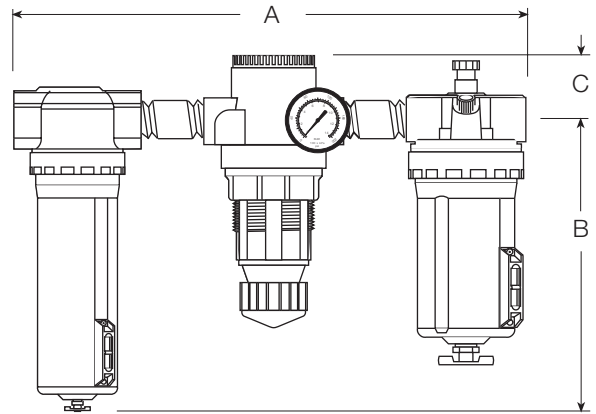

**REPLACEMENT FILTER ELEMENT KITS**

Element Type	Kit Number
40-µm bronze (Std element)	A114-106E3
5-µm bronze	A114-106E5

**ORDERING INFORMATION**

Change the letters in the sample model number below to specify the **FRL** you want.

**NOTE:** For model numbers longer than 15 characters, please consult Master Pneumatic.

**B FD RL289D - 10 Y NG W**

- FILTER DRAIN**
- Internal automatic drain .....FD
  - Manual drain.....F
  - External Hydro-Jector drain .....FE
  - Warrior electronic drain .....F2A

- PORT SIZE**
- 1-1/4 NPTF ..... 10
  - 1-1/2 NPTF ..... 12

**PORT TYPE**

- NPTF Threads ..... Leave Blank
- BSPF threads ..... W

**GAUGE**

- 0-200 psig Gauge ..... Leave Blank
- No gauge ..... NG

**OPTIONS** (*More than one option can be chosen*)

- None ..... Leave Blank
- Non-relieving regulator ..... A
- Sintered bronze filter element:
  - 5-µm rating ..... E5
- Adjusting springs:
  - 0-150 psig (0-10 bar) ..... H \*\*
  - 0-50 psig (0-3.4 bar) ..... L
- Remove adjusting key ..... JJ
- Delete bowl drain; 1/4 NPT female port instead ..... LDC
- Metal Dome ..... MD
- Limit maximum psig setting ..... M\*
- Regulator tee handle ..... T
- Quick-fill lubricator Q-cap ..... Q

\* Insert maximum limited ressure.

\*\* H option spring includes metal dome.

# SENTRY Modular Accessories

Sentry modular units use end plates secured with screws to hold the ports in place, and also to serve as mounting brackets. Short screws secure the end plates when a single module is used; long screws when two or more modules are used. Parts required for assembly are as follows:

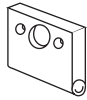

Sentry End Plate

Item	Part Number	Quantity Required		
		1 Unit	2 Units	3 Units
End Plate	10R-10	2	2	2
Short Screw	10R-18	4	2	0
Long Screw	10R-19	0	2	4
Small O-ring	103-95	1	1	1
Large O-ring	33-53	1	2	3
Ports		See Chart at Right		

Sentry assemblies can be fitted with either threaded pipe ports or ports for tubing. The sizes available are shown below. Two ports required for each assembly.

PIPE PORTS		TUBING PORTS	
Pipe Size	Port Number	Tubing Size	Port Number
G 1/8	10R-21-1/8W	1/4	A10R-21-04
G 1/4	10R-21-1/4W	3/8	A10R-21-06
1/8 NPT	10R-21-1/8	4 mm	A10R-21-M4
1/4 NPT	10R-21-1/4	6 mm	A10R-21-M6
		8 mm	A10R-21-M8
		10 mm	A10R-21-M10

# GUARDSMAN and VANGUARD Modular Accessories

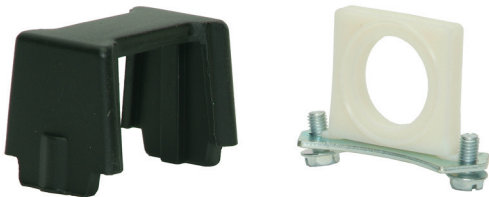

## MODULAR CONNECTORS

GUARDSMAN and VANGUARD modular components can be joined or removed quickly with these specially designed connectors. Each connector includes an O-ring assembly which forms an air-tight seal between modules. FRL and other assemblies include the required modular connectors between components, unless the assembly has been specifically ordered for connection with pipe nipples.

Connectors can be ordered as part number KA30-04.

## MODULAR MALE PORT

Used to connect modular units to non-modular units. Also allows right-angle connections by using the side ports or extra ports shown at the right.



Port Size	Male Port Part Number
1/4.....	30-11-1/4
3/8.....	30-11-3/8
1/2.....	30-11-1/2
3/4.....	30-11-3/4

## MODULAR FEMALE PORT

Used to connect modular units to piping at inlet or outlet.

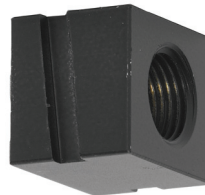

Port Size	Female Port Part Number
1/4.....	30-12-1/4
3/8.....	30-12-3/8
1/2.....	30-12-1/2
3/4.....	30-12-3/4

## MODULAR EXTRA PORTS

Used before or after a modular unit to supply three auxiliary 1/4 ports.

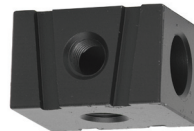

Port Size	Female Port Part Number
All.....	30-13

## MODULAR SIDE PORTS

Provides a right-angle female port at front, back, top, or bottom.

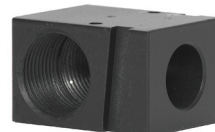

Port Size	Port Position	Part Number
1/4	Front & Back	30-15-1/4
3/8	Front & Back	30-15-3/8
1/2	Front & Back	30-15-1/2
1/4	Top	30-16U-1/4
3/8	Top	30-16U-3/8
1/2	Top	30-16U-1/2
1/4	Bottom	30-16D-1/4
3/8	Bottom	30-16D-3/8
1/2	Bottom	30-16D-1/2

# SERIES 380 Modular Accessories

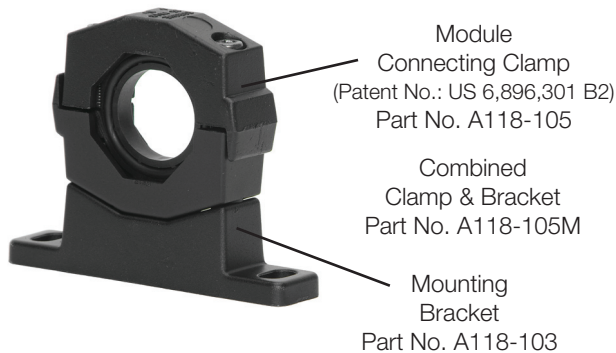
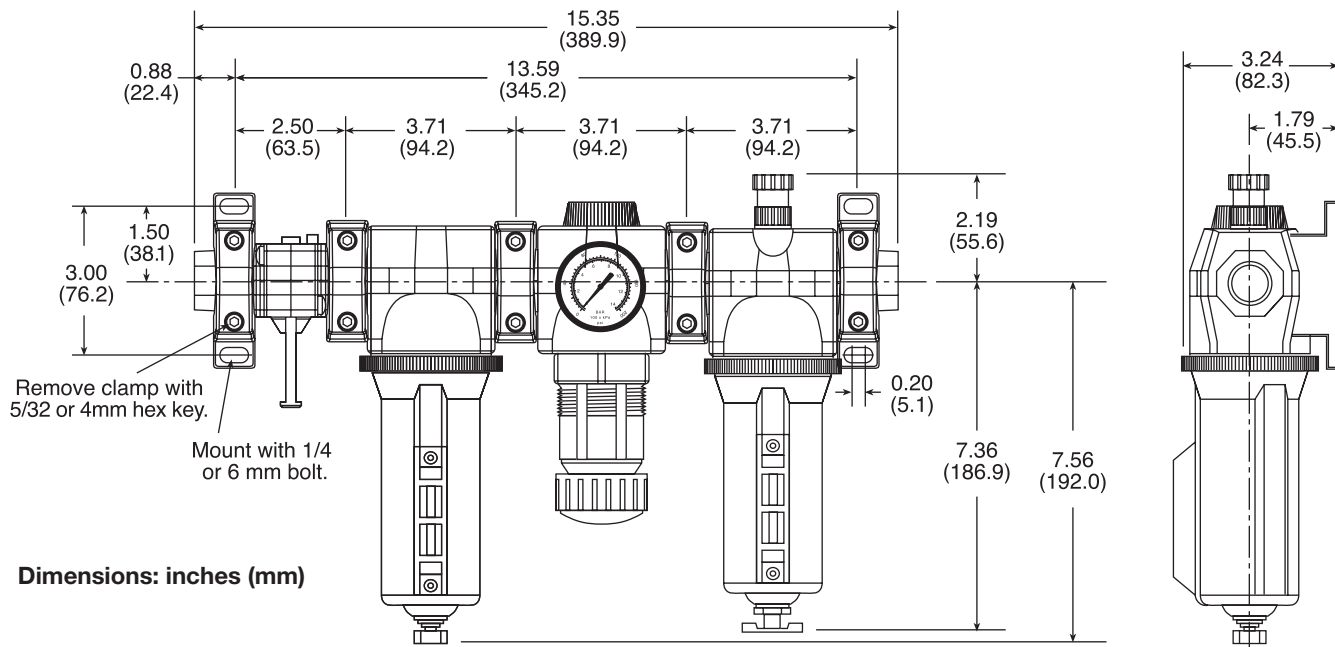

## CLAMP for MODULE CONNECTIONS

Specially designed clamps provide a quick and easy assembly or disassembly of Series 380 modules. Two allen-head bolts quickly tighten or loosen the clamp using a 5/32 or 4mm hex key. The clamp contains a plate carrying two O-rings to provide positive sealing between modules. Order clamp by part number A118-105. Combined clamp and bracket (below) can be ordered by part number A118-105M.

## MOUNTING BRACKET

Two brackets are normally used to mount an **FRL** to a vertical surface. The mounting bracket attaches to the module-connecting clamp (see above) with a single screw. Each bracket then employs two bolts (1/4" or 6mm) to connect the assembly to the mounting surface. Order bracket and screw by part number A118-103. Combined bracket and clamp (above) can be ordered by part number A118-105M.

## MALE and FEMALE END PORTS

Either male or female end ports can be attached to threaded inlet and outlet lines. This allows all modules of an FRL assembly to be removed easily and quickly without having to unthread the end modules. The end ports are attached to the modules with clamps (see at left). End ports can be included in an assembled FRL or ordered separately by the following part numbers:



Port Size	Male Number	Female Number
3/8 NPTF	—	118-100-3
1/2 NPTF	118-109-4F	118-100-4
3/4 NPTF	118-109-6F	118-100-6

## EXTRA PORT BLOCK



An extra port block can be placed between modules to provide two auxiliary 1/4 **NPTF** ports. Its mounting position can be rotated to obtain the most convenient operating orientation. If only one auxiliary port is to be used, the unused port must be closed with a pipe plug. (The inlet and outlet are not threaded.) Order with **FRLs** (see page 276) or order by the following part numbers:

Port Size	Part Number
1/4 NPTF	118-106-2
3/8 NPTF	118-106-3
1/2 NPTF	118-106-4

# Mounting Accessories

## REGULATOR MOUNTING BRACKETS

Regulators and integral filter/regulators can be mounted to a surface with a bracket that attaches to the regulator. Brackets and mounting nuts can be ordered separately or in a kit which includes both bracket and mounting nut.

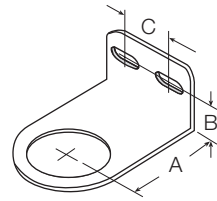

Guardsman, Guardsman II, R75, Series 380 and Vanguard

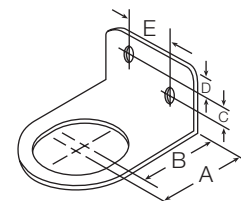

Sentry, Miniature

Usage	Part Numbers			Dimensions inches (mm)			Panel Mounting Hole Diameter inches (mm)
	Kit	Bracket	Nut	A	B	C	
GUARDSMAN, GUARDSMAN II	K60R-15	60R-15	60R-14P	2.38 (60)	1.00 (25)	1.50 (38)	1.56 (40)
R75	—	35-25	—	2.38 (60)	1.00 (25)	1.50 (38)	1.88 (48)
SERIES 380, VANGUARD	K37-71	37-71	37-32	2.38 (60)	1.00 (25)	1.50 (38)	2.06 (52)

Usage	Kit	Bracket	Nut	A	B	C	D	E	Diameter inches (mm)
SENTRY, MINIATURE	A33-82	33-82	10R-26	1.375 (35)	1.25 (32)	0.31 (8)	0.31 (8)	.69 (17)	1.19 (30)

## MODULAR MOUNTING BRACKETS

Two L-shaped metal brackets as shown at the right can be used for wall mounting of modular FRLs or Clean Air Packages. A single bracket can be used to mount individual filters or lubricators. Kits include two brackets and four screws for attaching the brackets to the modules.

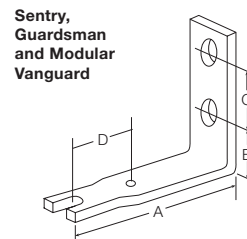

Sentry, Guardsman and Modular Vanguard

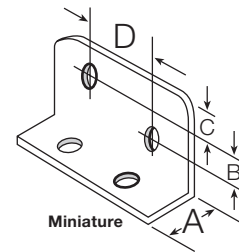

Miniature

Usage	Kit Number	Bracket Number	Dimensions inches (mm)			
			A	B	C	D
SENTRY			Mounts with screws, number 10R-19 (two required)			
GUARDSMAN and Modular VANGUARD	K30-08	30-08	3.0 (76)	0.88 (22)	1.00 (25)	1.20 (31)
MINIATURE*	K50-01	50-01	0.63 (16)	0.31 (8)	0.31 (8)	.69 (17)

\* = Can only be used in conjunction with 'T' suffix option on FD50, FCD50, and L50 products.

## FRL INLINE MOUNTING PIPE BRACKETS

Two pipe brackets can be used for wall mounting of FRL assemblies that use pipe nipples to join the components. The bracket kits listed below include two sets of brackets.

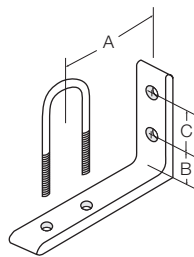

Nipple Size	Kit Number	Dimensions inches (mm)		
		A	B	C
1/4	UMB-2			
3/8	UMB-3	2.72 (28)	0.50 (13)	1.00 (25)
1/2	UMB-4			
3/4	UMB-6	3.69 (94)	1.13 (29)	1.25 (32)
1	UMB-8			

## MOUNTING BRACKETS for High-Capacity VANGUARD 3/4- and 1-INCH MODELS

Individual filters and lubricators with 3/4- or 1-inch ports can be mounted to a vertical surface using the brackets listed below.

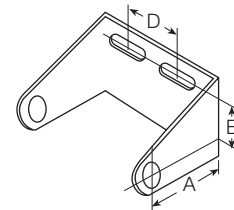

Pipe Size	Bracket Number	Dimensions inches (mm)		
		A	B	C
3/4	109-33-3/4	2.5 (64)	1.5 (38)	2.13 (54)
1	109-33-1	2.5 (64)	1.5 (38)	2.13 (54)

**Note:** No mounting brackets available for PR180M, PRH180M, 1-1/4" or 1-1/2".

## TUBE-AWAY KITS



Tube-Away kits for VANGUARD and 380 Series filters with automatic drains are available to carry liquid drainage to a remote disposal point. Order by the part numbers below.

- With 3-ft (1-meter) tubing .....K802-21-3
- With 6-ft (2-meter) tubing .....K802-21-6
- With 12-ft (4-meter) tubing .....K802-21-12

## QUICK-FILL CAP FOR LUBRICATORS

Quick-fill caps (Q-caps) are check-valve fittings for filling lubricators. They can be ordered as a lubricator option, and are also available by the following part numbers.



Usage	Part Number	Threads
MINIATURE SENTRY GUARDSMAN	A203-8BH	3/8-24
SERIES 380	KA117-109	1/2-13
VANGUARD	A204-8BH	1/2-13

## PRESSURE GAUGES



Gauges are made with “shatter-proof” plastic faces for use in rugged environments. Large numerals show psig in black and bar in red. Heavy duty construction of bourdon and indicator dial. Accuracy is within 2 to 3 percent.

All regulators and assemblies with regulators include a gauge with a range of 0–200 psig (0–13.8 bar). **SENTRY** and **MINIATURE** models have a 1/8 NPT connection, and 1-1/2 inch diameter gauge face. All other models have a 1/4 NPT pipe connection, and the gauge face is 2 inches (51 mm) in diameter. Gauges are also available by the following part numbers.

Pressure Range psig (bar)	Dial Diameter inch (mm)	Pipe † Connection NPT	Part Number
0–60 (0–4.1)	2 (51)	1/4	60BDD
0–200 (0–13.8)	2 (51)	1/4	200-BDD
0–30 (0–2.1)	1.5 (38)	1/8	30MDD
0–60 (0–4.1)	1.5 (38)	1/8	60MDD
0–160 (0–10.3)	1.5 (38)	1/8	70MDD

† Back mounting connection.

## MINI MUFFLERS

An economical aid to noise reduction.



**M10-1**

1/8" NPT brass body with sintered bronze element



**M5-1**

1/8" NPT brass body with sintered bronze element. Designed to fit internally into 1/8" port



**03982B**

1/8" NPT to 1/4" NPT reducer

# Silencer/Reclassifiers

# RS and MRS Models Port Size: 1/2 to 1



Model Shown: RS100-4

Model Shown: MRS100-8

Silencer/reclassifiers are integral silencer and oil separation devices. When installed at the exhaust ports of pneumatic valves they reduce exhaust noise and capture lubricants contained in the exhausting air. They are used on valve-cylinder applications and on air tools with piped exhausts.

- ◆ Exhaust noise is reduced to 80 to 85 dba under standard steady-state test conditions.
- ◆ Peak impact noise is reduced to 106 to 108 dba.
- ◆ A drain cock is supplied for manual or automatic draining of accumulated liquids. An optional 1/8 tube fitting (00142W) is available for automatic draining.
- ◆ NPTF port threads; optional BSPP threads.

## SOUND ATTENUATION DATA

Constant-flow tests were conducted in a 14' x 22' room with a 14' ceiling. Sound pressure levels were recorded using a B & K precision impulse sound meter (model 22045), a 1-inch microphone (DB0375), a flexible extension rod (UA0196), and a random incidence corrector (UA0055). Test system as mounted on the 14-foot wall with exhaust port 4 feet from the 14-foot wall.

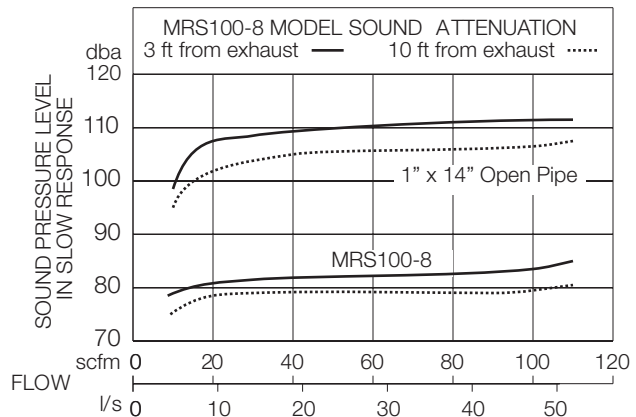
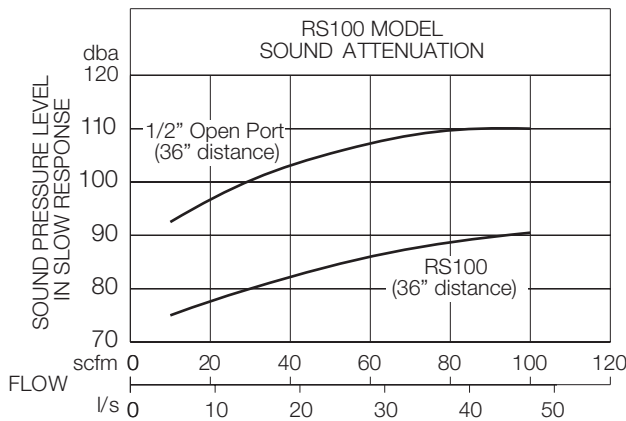

## SPECIFICATIONS

### Ambient/Media Temperature:

Plastic Bowls: 40° to 125°F (4° to 51°C).  
RS Metal Bowls: 40° to 175°F (4° to 79°C).

**Bowl:** Polycarbonate plastic. Optional steel shatterguard

**Element:** Sintered bronze.

**Fluid Media:** Compressed air.

### Inlet Pressure:

5 to 150 psig (0.3 to 10 bar) maximum.

**See back pressure performance data on the facing page.**

## DIMENSIONS inches (mm)

Port Size	Model Number	A	B	C	Depth	Weight lb (kg)
1/2	RS100-4	3.5 (89)	5.5 (140)	0.7 (18)	3.5 (89)	1.3 (0.59)
1/2	MRS100-4	4.2 (107)	8.4 (213)	2.7 (69)	4.2 (107)	2.8 (1.27)
3/4	MRS100-6	4.2 (107)	8.4 (213)	2.7 (69)	4.2 (107)	2.8 (1.27)
1	MRS100-8	4.2 (107)	8.4 (213)	2.7 (69)	4.2 (107)	2.8 (1.27)

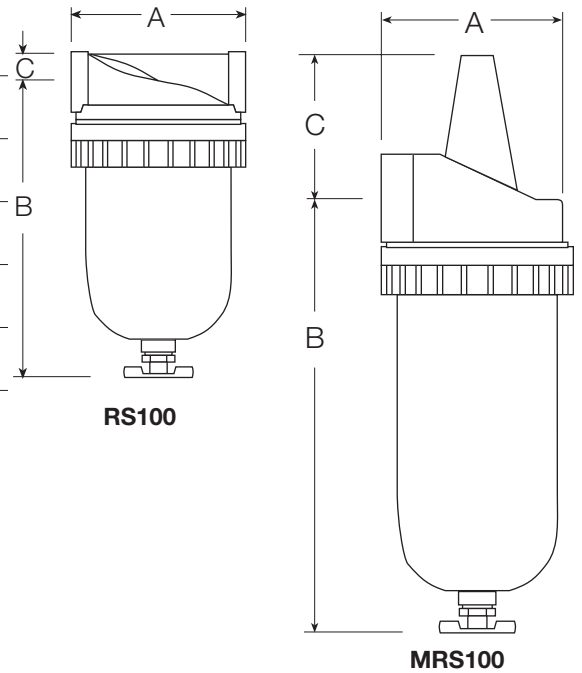

**Absorbing Filters, Dryers,  
Clean Air Packages**

## REPLACEMENT ELEMENT KITS

RS Models . . . . . KA103-03E4

MRS Models . . . . . KA109-32

## TYPICAL INSTALLATION IN A VALVE-CYLINDER CIRCUIT

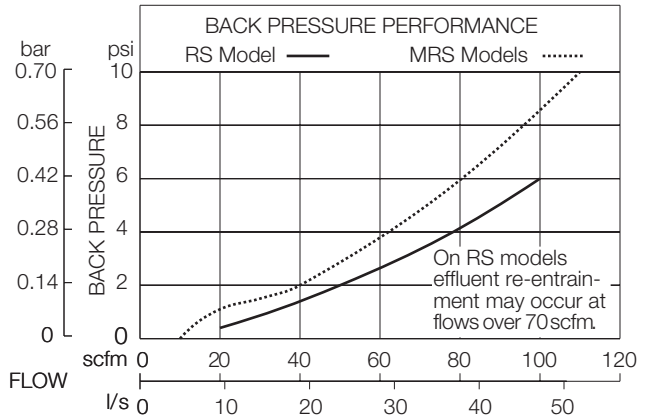
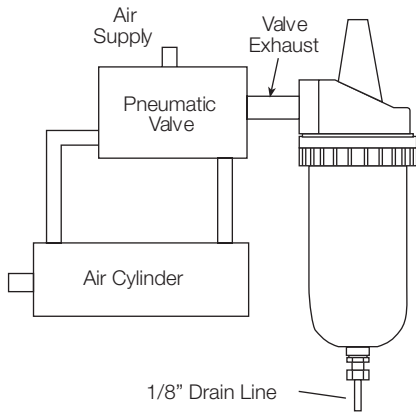

## ORDERING INFORMATION

Change the letters in the sample model number below to specify the silencer/reclassifier you want.

B RS 100 - 4 Y W

<p><b>BOWL TYPE</b></p> <p>Metal bowl..... B</p> <p>Plastic bowl..... Leave Blank</p> <p><b>BOWL SIZE</b></p> <p>8-Ounce (240-ml) bowl..... RS</p> <p>16-Ounce (480-ml) bowl..... MRS</p> <p><b>PORT SIZE</b></p> <p>1/2 NPTF..... 4</p> <p>3/4 NPTF (only with MRS bowl) ..... 6</p> <p>1 NPTF (only with MRS bowl) ..... 8</p>	<p><b>PORT TYPE</b></p> <p>NPTF Threads ..... Leave Blank</p> <p>BSP threads ..... W</p> <p><b>OPTION</b></p> <p>None ..... Leave Blank</p> <p>Bowl shatterguard ..... SG</p>
--	---

# External Float-Actuated Drain

## Automatic Float Drain

# BD130 Models

## Port Sizes: 1/4, 1/2



Model Shown: BD130-2

- ◆ Heavy-duty, corrosion proof
- ◆ Auto draining where pressure drop is not available

The automatic float drain attaches to the bottom of drain legs (or vertical air lines) to remove accumulated moisture automatically. It is also suitable for attachment to any **VANGUARD** or **SERIES 380** filter; this requires the **LDC** (less drain cock) option. In addition, it can be used as the drain on Series 25 MP-Filenco dryer/filters.

The drain is a normally open, pilot-operated valve rated for 10-250 psig (0.7-17 bar) at temperatures up to 175°F (79°C). The valve is held closed by line pressure. The pilot valve is never submerged in water, and its discharge is operated by system air pressure. The float is extremely light; it cannot leak or hold fluid. All parts are corrosion proof.

The drain has a manual override to check proper functioning. Discharge is easily piped to a remote location. When the compressed air system is shut down, the valve returns to its normally open condition and water will drain by gravity.

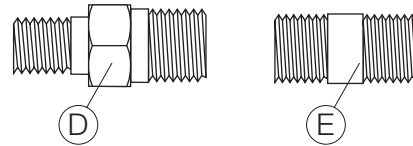
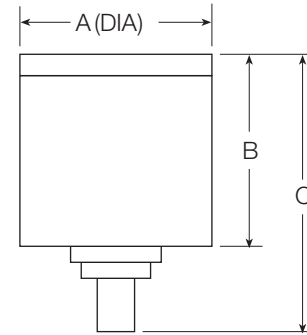

### DIMENSIONS inches (mm)

Bowl	A	B	C	Depth
BD130-2	2.5 (64)	2.4 (60)	3.3 (83)	2.5 (64)
BD130-4	2.5 (64)	2.4 (60)	3.3 (83)	2.5 (64)

### PORT SIZES

Model Number	Inlet (NPTF)	Outlet Drain (NPTF)	Pipe Nipple (NPT)	
BD130-2	1/4	1/8	(D) 1/4 x 1/8	(E) 1/4 x 1/4
BD130-4	1/2	1/8	Not supplied with product	



# Electronically Controlled WARRIOR Drain

The **WARRIOR** drain is designed to remove condensate from components in compressed air systems. Typical installations include compressors, dryers, receivers, driplegs, and filters.

The drain consists of a timer and a valve. Electronic controls allow the draining interval to be set from 0.5 to 45 minutes, and the drain time from 0.5 to 10 seconds. Once set, draining action is automatic and requires no maintenance. This is important in constant-flow applications where there is no on-off action to trigger a standard automatic drain.



Model Shown: DED-115V-2

## SPECIFICATIONS

**Drain Time:** Adjustable 0.5 to 10 seconds.

**Drain Interval:** Adjustable 0.5 to 45 minutes.

**Current Consumption:** 4 ma maximum.

**Ambient Temperature:** 35° to 130°F (2° to 54°C).

**Media Temperature:** 35° to 190°F (2° to 88°C).

**Electrical Connection:** DIN 43650A, ISO 440/6952.

**Valve Type:** 2/2 direct acting, normally closed.

**Valve Body:** Forged brass; 3/16-inch (4.8 mm) orifice.

**Maximum Pressure:** 230 psig (16 bar).

## DIMENSIONS inches (mm)

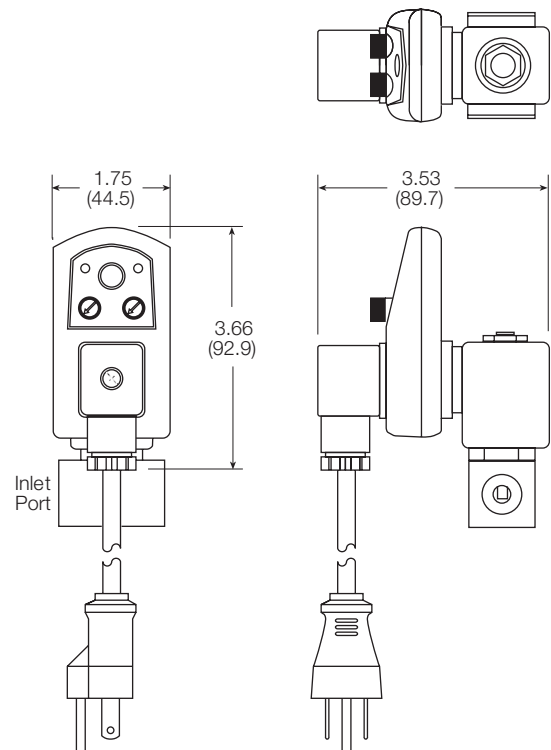

## ORDERING INFORMATION

Pipe Size*	Voltage	Drain Only Product Number
1/4 NPTF	115 VAC, 50/60 Hz †	DED-115V-2
3/8 NPTF	115 VAC, 50/60 Hz †	DED-115V-3
1/2 NPTF	115 VAC, 50/60 Hz †	DED-115V-4
1/4 NPTF	24 VDC	DED-24V-2
3/8 NPTF	24 VDC	DED-24V-3
1/2 NPTF	24 VDC	DED-24V-4
1/4 NPTF	230 VAC	DED-230V-2
3/8 NPTF	230 VAC	DED-230V-3
1/2 NPTF	230 VAC	DED-230V-4

\* For BSPP threads, add W to the end of the product number.

† Specified range of 110 - 120 VAC

# PRESSURE / VACUUM Switches

# PDA Models Port Sizes: 1/8, 1/4



**Model Shown:** PDA414-2

Pressure/Vacuum switches can provide an electrical signal to warn or prevent over- or under-pressurization which can be harmful to a machine or process. The pressure is adjustable. Switches are sealed, vibration resistant, and built to provide reliable protection. They can be either direct or remotely mounted. Switches are available in three basic configurations:

Flying leads with 18-inch (450-mm) wires.  
Flying leads with female weather pack.  
For use with DIN connectors.

## Modular Installation

Any of the pressure valves can be incorporated into any of the **GUARDSMAN, SERIES 380**, or **VANGUARD** modular FRL assemblies. For information about such installations, contact Master Pneumatic.

## SPECIFICATIONS

**Ambient/Media Temperature:**

-40° to 180°F (-40° to 80°C).

**Electrical:**

5 ampere at 125 / 250 VAC

5 ampere at 12 / 24 VDC

**Housing:** Glass-filled nylon.

**Pressure Fitting:** Brass, optional stainless steel

**Maximum Overpressure:** 350 psig (25 bar).

**Repeatability:** ± 2% of full set point range at 70°F (20°C) ambient temperature.

**Weight:** 0.3 lb (0.14 kg).

**DIMENSIONS  
inches (mm)**

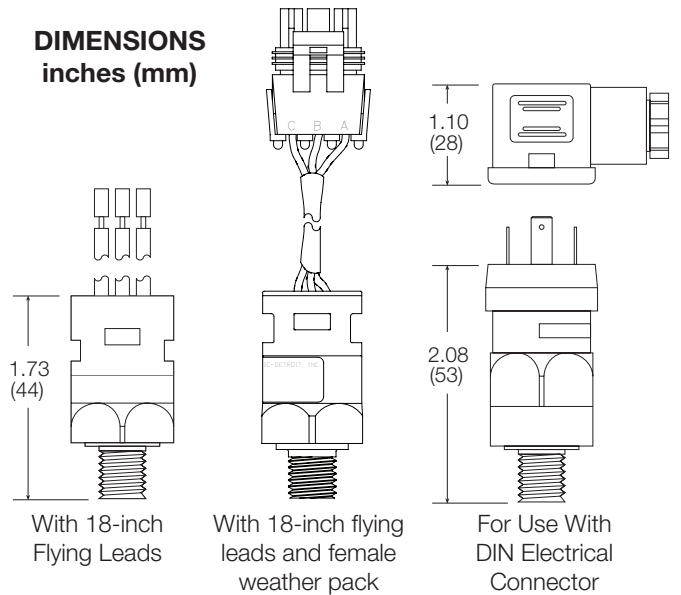

**ORDERING INFORMATION**

Change the numbers in the sample model number below to specify the switch you want. These switches can also be ordered with FRL units. For vacuum applications consult Master Pneumatic.

**PDA 2 1 1 - 2 A W**

**ADJUSTMENT RANGE**

- 3-7 psig (0.2-0.5 bar) ..... 1
- 5-30 psig (0.35-2 bar) ..... 2
- 25-100 psig (1.7-6.9 bar) ..... 4

**CIRCUIT TYPE**

- SPDT ..... 1
- SPST normally open ..... 2  
(must use **electrical connection 1 or 2**)
- SPST normally closed ..... 3  
(must use **electrical connection 1 or 2**)

**ELECTRICAL CONNECTION**

- 18-inch (450-mm) flying leads ..... 1
- Flying leads & female weather pack ..... 2
- DIN 43650A, male half only ..... 3
- DIN 43650A cable clamp ..... 4
- DIN 43650A 1/2-inch (13-mm) ..... 5  
female conduit

**PIPE SIZE**

- 1/8 NPT ..... 1
- 1/8 BSP (Brass pressure fitting only) ..... 1  
See port type for additional add-on
- 1/4 NPT. For 1/4 BSPP port threads ..... 2
- 1/4 BSP ..... 2  
See port type for additional add-on
- 7/16-20 SAE ..... S7

**PORT TYPE**

- NPT Threads ..... Leave Blank
- BSP threads ..... W

**OPTIONS**

- Viton diaphragm ..... A
- EPDM diaphragm ..... B
- 10-ampere rating ..... E
- Gold electrical contacts ..... F
- DIN light 110 volt AC ..... G  
(must be used along with option 4 under **Electrical Connection** section)
- DIN light 12 volt DC ..... H  
(must be used along with option 4 under **Electrical Connection** section)
- DIN light 24 volt DC ..... J  
(must be used along with option 4 under **Electrical Connection** section)
- 316 Stainless Steel ..... M  
pressure fitting

# MPS Pressure Sensors

## INDIVIDUAL PRESSURE SENSORS



**GUARDSMAN & VANGUARD EXTRA PORT MODULAR KITS**  
Available only in 60, 70, and 100 Series



**ASSEMBLIES with REGULATORS**

## OUTPUT MODES

The **MPS** sensor has two independent **NPN** or **PNP** open collector output signals. An analog output is optional.

The Switch Output Mode (see diagram at the right) has a switch point programmed by the user at a specific pressure. The hysteresis range ( $h$ ) adjustment controls the output signal from 0 to 100% below the switch point ( $H$ ).

The Window Comparator Mode (see diagram at the right) provides two switchpoint settings ( $A$ ) and ( $b$ ) that control the output signals (**NPN/PNP**) between two pressures. This is referred to as the high/low setting.

The optional analog output is calibrated to the pressure scale of the sensor.

- ◆ Panel mounting; inline mounting; modular assembly.
- ◆ Four operating pressure ranges:  
Positive pressure.....0 to 145 psi  
Vacuum pressure .....0 to -30 in Hg  
Low pressure .....0 to 14.7 psi  
Compound ..... -14.7 to 72.5 psi
- ◆ Two **NPN** or **PNP** (sourcing) and **NPN** (sinking) open collector.
- ◆ Output response time less than 2 milliseconds, or can be programmed.
- ◆ Switch point and high/low programming.
- ◆ Selectable units of measure:  
(1) mm Hg, -bar, -kPa, in Hg.  
(2) kgf/cm<sup>2</sup>, PSI, bar, kPa.
- ◆ IP65 rated and CE marked.
- ◆ Uses air or non-corrosive gases.
- ◆ Displays error message.

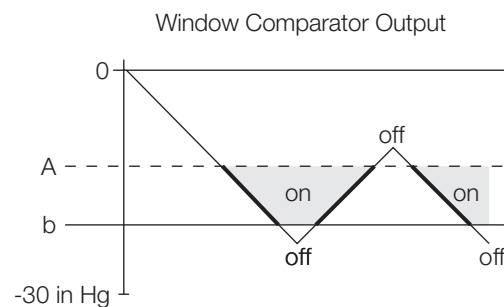
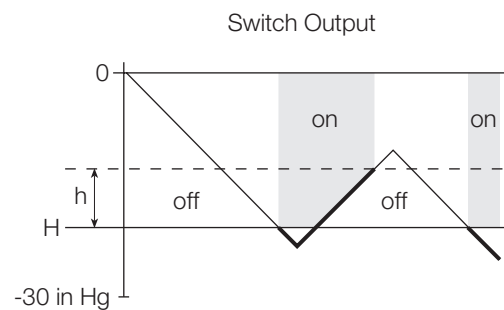

(Continued on Next Page)

# MPS Pressure Sensors (continued)

**DIMENSIONS** inches (mm)

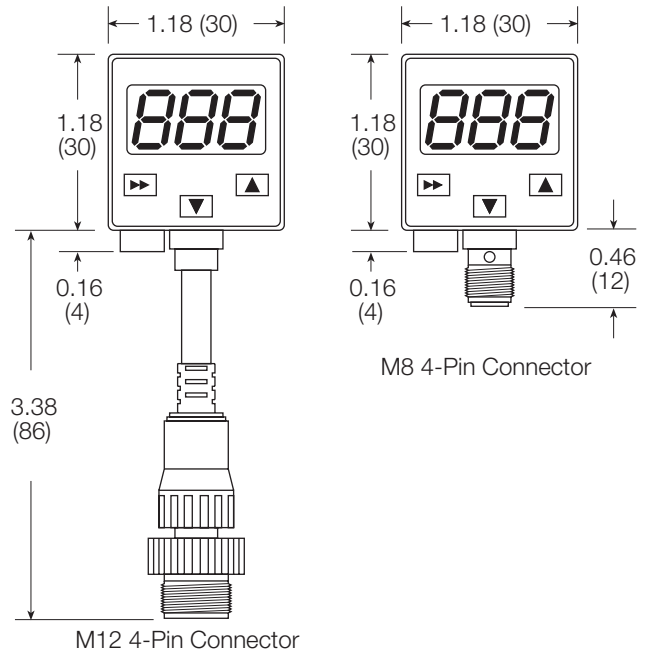

## ACCESSORY CABLES

2-Meter Cables

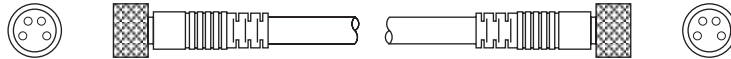

Model 33-548-2M

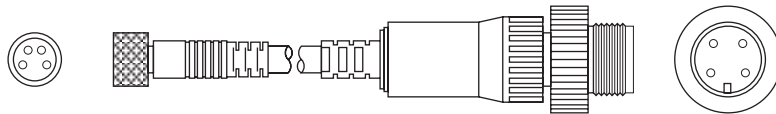

Model 33-549-2M

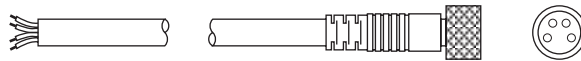

Model 33-550-2M

## ORDERING INFORMATION for MPS PRESSURE SENSOR (Without Regulator)

Change the letters in the sample model number below to specify the sensor you want.

**MPS - 1 A 1 A 1 A 0**

### PRESSURE SENSOR ASSEMBLY

- Individual pressure sensor unit..... A
- Pressure sensor with 1/8" plug and brass hex fitting for regulators. .... B
- Pressure sensor with extra port and one modular connector. (Guardzman & Vanguard modular units only) ..... C

### PRESSURE RANGE

- 0 to 145 psig (positive pressure) ..... 0
- 0 to 14.7 psig (low pressure)..... 1
- 0 to -30 in Hg (vacuum) ..... 2
- 14.7 to 72 psig (compound) ..... 3

### ELECTRICAL CONNECTOR

- 4-Pin, M8 ..... A
- 4-Pin, M12 ..... B

### CIRCUIT

- NPN sinking output ..... 0
- PNP sourcing output ..... 1

### PORT SIZE

- 1/8 NPTF..... A

## ORDERING INFORMATION for MPS PRESSURE SENSOR WITH REGULATOR

Change the letters in the sample model number below to specify the regulator/sensor you want.

**A 4 A-MPS-1 A 1 A 1 A 0**

### REGULATOR: Modular extra port and modular clamping included.

- R60 (See pages 120-121)..... A
- R60-H (See pages 120-121)..... B
- R75 (See pages 122-123)..... C
- R75-H (See pages 122-123)..... D
- R100 (See pages 124-125)..... E
- R100-H (See pages 124-125)..... F
- IR100 (See pages 136-137)..... G
- IR100-H (See pages 136-137)..... H
- PR100 (See pages 144-145) ..... J
- PR100-H (See pages 144-145) ..... K

### REGULATOR PORTS

- 3/8 NPTF..... 3
- 1/2 NPTF..... 4
- 3/4 NPTF (R100 regulators only)..... 6
- 3/8 BSPP ..... C
- 1/2 BSPP ..... D
- 3/4 BSPP (R100 regulators only) ..... E

### PRESSURE SENSOR ASSEMBLY

- Individual pressure sensor unit..... A
- Pressure sensor with 1/8" plug and brass hex fitting for regulators. .... B
- Pressure sensor with extra port and one modular connector. (Guardzman & Vanguard modular units only) ..... C

### ELECTRICAL CONNECTOR

- 4-Pin, M8 ..... A
- 4-Pin, M12 ..... B

### CIRCUIT

- NPN sinking output ..... 0
- PNP sourcing output ..... 1

### PORT SIZE

- 1/8 NPTF..... A

### PRESSURE RANGE

- 0 to 145 psig (positive pressure) ..... 0
- 0 to 14.7 psig (low pressure)..... 1
- 0 to -30 in Hg (vacuum) ..... 2
- 14.7 to 72 psig (compound) ..... 3

# SERV-OIL Reservoirs

Servo-Meters can be supplied with oil by pressure systems (up to 30 psig) or gravity systems, although gravity systems are generally preferred. Remote reservoirs should be connected to the bottom port of the **SERV-OIL** equipment with a minimum 5/16" I.D. line.

Stand- pipes should be installed from the top of the equipment and extend above the reservoir for gravity systems to prevent airlock of the Servo-Meters.

Sight domes are available to vent air from the system, and to confirm visually the presence of oil. Pressure-fill systems should be vented, or use low velocity recirculation of the oil supply.

Capacities. Transparent reservoirs are available in 10-ounce (300-ml), 1-quart (960-ml), and 2-quart (1920-ml) capacities; metal reservoirs in 1-gallon (3.8-liter), 5-gallon (18.9-liter), and 10-gallon (38-liter) capacities. Metal reservoirs have an internal oil filter, sight tube, and filter breather fill cap. All reservoirs have quick-fill fittings.

Level Switches. When the reservoir is located where the oil level cannot easily be determined visually, electrical oil level switches can be used. Both low-level and high-level switches are available except for 10-ounce reservoirs. The switches can be connected to a remote electrical control for automatic filling.

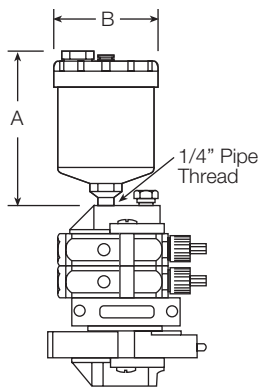

### Transparent Reservoir Shown on MPL

Part No.	Capacity†
M476R	10 oz (0.3 l) (7970 drops) (polycarbonate bowl)
M476RN	10 oz (0.3 l) (nylon bowl)
M476RP	10 oz (0.3 l) (polypropylene bowl)

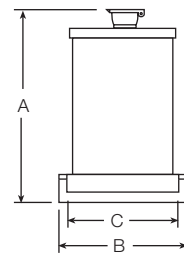

### Transparent Reservoir

Part No.	Capacity†
M570-6R	1 qt (0.9 l) (25,400 drops)
M570-12R	2 qt (1.9 l) (50,800 drops)

1/4 NPTF Port

† One drop = 1/30 cc. Capacity in drops is at 90% of full capacity.

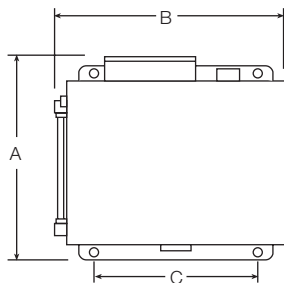

3/4 NPTF Port

### Metal Reservoir Includes internal oil filter, sight tube, quick-fill fitting, and filter breather fill cap.

Part No.	Capacity†
473R	1 gal (3.8 l) (102,000 drops)
477R	5 gal (19 l) (508,000 drops)
479R	10 gal (38 l) (1,020,000 drops)

### ACCESSORIES for RESERVOIRS

#### Low-Level Switch (not for 10-oz models):

Add suffix G to reservoir part number.

#### High- and Low-Level Switches

(not for 10-oz models):

Add suffix GG to reservoir part number.

#### Sight Dome & Remote Indicator:

Side Mounting: Part M481R

Top Mounting: Part 482R

### NOTE

For most applications Master Pneumatic recommends a light spindle oil that is not chemically aggressive. (150-1200 ssu viscosity).

### RESERVOIR DIMENSIONS

Part No.	Capacity	Dimensions inches (mm)			
		A	B	C	Depth
M476R	10 ounces	5.4 (137)	3.3 (84)	—	3.3 (84)
M476RN	10 ounces	5.4 (137)	3.3 (84)	—	3.3 (84)
M476RP	10 ounces	5.0 (127)	3.3 (84)	—	3.3 (84)
M570-6R	1 quart	7.6 (193)	5.4 (137)	4.6 (117)	4.8 (122)
M570-12R	2 quarts	13.6 (345)	5.4 (137)	4.6 (117)	4.8 (122)
473R	1 gallon	9.9 (251)	10.9 (276)	8.0 (203)	6.1 (154)
477R	5 gallons	17.9 (455)	14.9 (378)	12.0 (305)	6.1 (154)
479R	10 gallons	25 (635)	16.9 (429)	13.5 (343)	7.1 (180)

# SERV-OIL Accessories

**BLOCK PLATE.** Used between Servo-Meters in a stack to block air signals. Different actuating air signals can then be used for the two groups of Servo-Meters separated by the block plate. The oil supply, however, is not blocked by the plate.

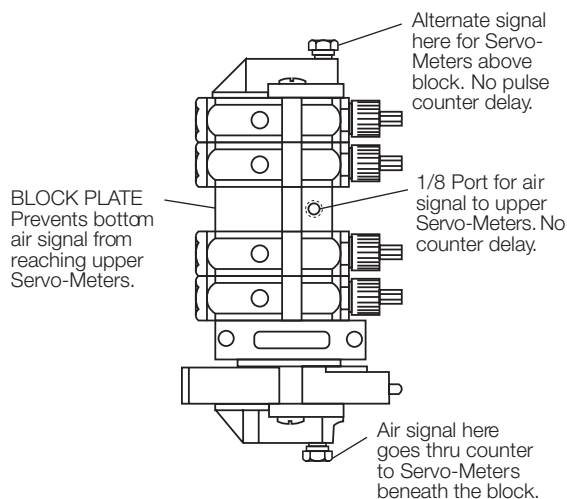

Block Plate Kit with **NPT** Threads .....K474-07T  
Includes all necessary seals and assembly hardware. For **BSPP** threads add suffix W to part number.

**CHECK VALVES.** Used at lubrication point to keep air out of oil lines. **NPT** threads, Nitrile seals. For **BSPP** threads add suffix W to the part number; for Viton seals add suffix letter V. Both straight check valves and right-angle elbow valves are available.

Part No.	Type	Inlet	Outlet
A01242	Elbow	1/8 Female	1/8 Male
A01242L *	Elbow	1/8 Female	1/8 Male
A01244	Elbow	1/8 Female	1/4 Male
A01242S	Straight	1/8 Female	1/8 Male
A01242SL *	Straight	1/8 Female	1/8 Male
A01244S	Straight	1/8 Female	1/4 Male
A01284S	Straight	1/4 Female	1/4 Male
A01284SL *	Straight	1/4 Female	1/4 Male

\* = Lower cracking pressure.

**PULSE COUNTER KIT for MPLs.** A pulse counter can be set to actuate Servo-Meters on every operating cycle, every 5th cycle, or every 10th cycle. Counter Kit KA418-04M includes a counter, and all necessary seals and hardware for mounting.

## CONNECTORS for TUBING

Connector Part No.	Description	Usage
00142W	1/8" NPT x 1/8"	Nylon or Copper Oil Delivery Lines
00182W	1/8" NPT x 1/4"	Nylon or Copper Oil Delivery Lines
001124W	1/4" NPT x 3/8"	Nylon or Copper Air Signal or Oil Delivery Lines
02942M	Double Barbed Connector for Splicing 1/8" Tubing	Oil Delivery Lines

Note: Tube fittings are not available with BSPP threading

**TUBING.** Tubing lengths should be specified as showned below:

Tubing Part No.	Description	Usage
-----------------	-------------	-------

### NON-FILLED TUBING

00942M-*	1/8" O.D. Nylon	Oil Delivery Lines
B00942M-@	1/8" O.D. Nylon	Oil Delivery Lines
B00942F-#	1/8" O.D. Nylon	Oil Delivery Lines
00984M	1/4" O.D. Nylon	Air Signal Lines

### PRE-FILLED TUBING (tubing is filled and capped)

A00942M-@	1/8" O.D. Nylon,	Oil Delivery Lines
A00942F-#	1/8" O.D. Nylon,	Oil Delivery Lines

\* = 1 inch of tubing. Ex: -12 = 12 inches.

@ = 1 meter of tubing. Ex: -12 = 12 meters

# = 1 Foot of tubing. Ex: -12 = 12 feet.

**SEAL KITS for SERVO-METERS.** Seals for the air end are Nitrile; seals for the oil end are available in three different materials: Nitrile, Viton, or Ethylpropylene. For satisfactory service it is recommended that seals be replaced completely on both the air end and the oil end.

Servo-Meter	Buna-N Seals for Air End	Buna-N† Seals for Oil End
1/2 Drop, Non-shutoff	KA457-37M-5	KA457-12-5I
1/2 Drop, Shutoff	KA457-38M-5	KA457-12-5I
1 Drop, Non-shutoff	KA457-37M-1	KA457-12-1I
1 Drop, Shutoff	KA457-38M-1	KA457-12-1I
2 Drops, Non-shutoff	KA457-37M-2	KA457-12-2I
2 Drops, Shutoff	KA457-38M-2	KA457-12-2I

† For Oil End Seals only: Add suffix V for Viton seals. Add suffix E for EPR seals.



# ***PneuCool* COOLANT CONCENTRATE** for **SCORPION SYSTEMS**

***PneuCool*** is a semi-synthetic, water-soluble coolant concentrate specially formulated for **Scorpion** systems. It has effective pressure- and friction-reducing properties for the optimum balance of cooling and lubrication. It also provides rust protection and reduces tool wear by reducing friction and temperature. These same features also increase machining accuracy by reducing thermal expansion of tool and workpiece.

***PneuCool*** can be used with all types of metals, but is especially effective with aluminum alloys. It is available in one-gallon and five-gallon containers, and is very economical because of the precision delivery of **Scorpion** systems.

There is no chlorine, phosphorus, active sulphur, silicones, phenols, or nitrates in ***PneuCool***. Highly concentrated ***PneuCool*** must be diluted with water before use. Recommended dilutions for various machining operations are shown below.

## **Machining Operation**

## **Parts of Water to One Part of *PneuCool***

Boring, Drilling, Sawing, Reaming, Milling, Planing, Gear Cutting .....	20–30
Threading, Broaching .....	10–20
Grinding .....	30–60
Metalforming .....	0–5

Order ***PneuCool*** by the following part numbers:

1 Gallon .....	PC-1GAL
5 Gallon .....	PC-5GAL

An 8-ounce sample is included with each **Scorpion** unit.



# Serv-Oil PNEUMATIC INJECTION LUBRICATION CHART

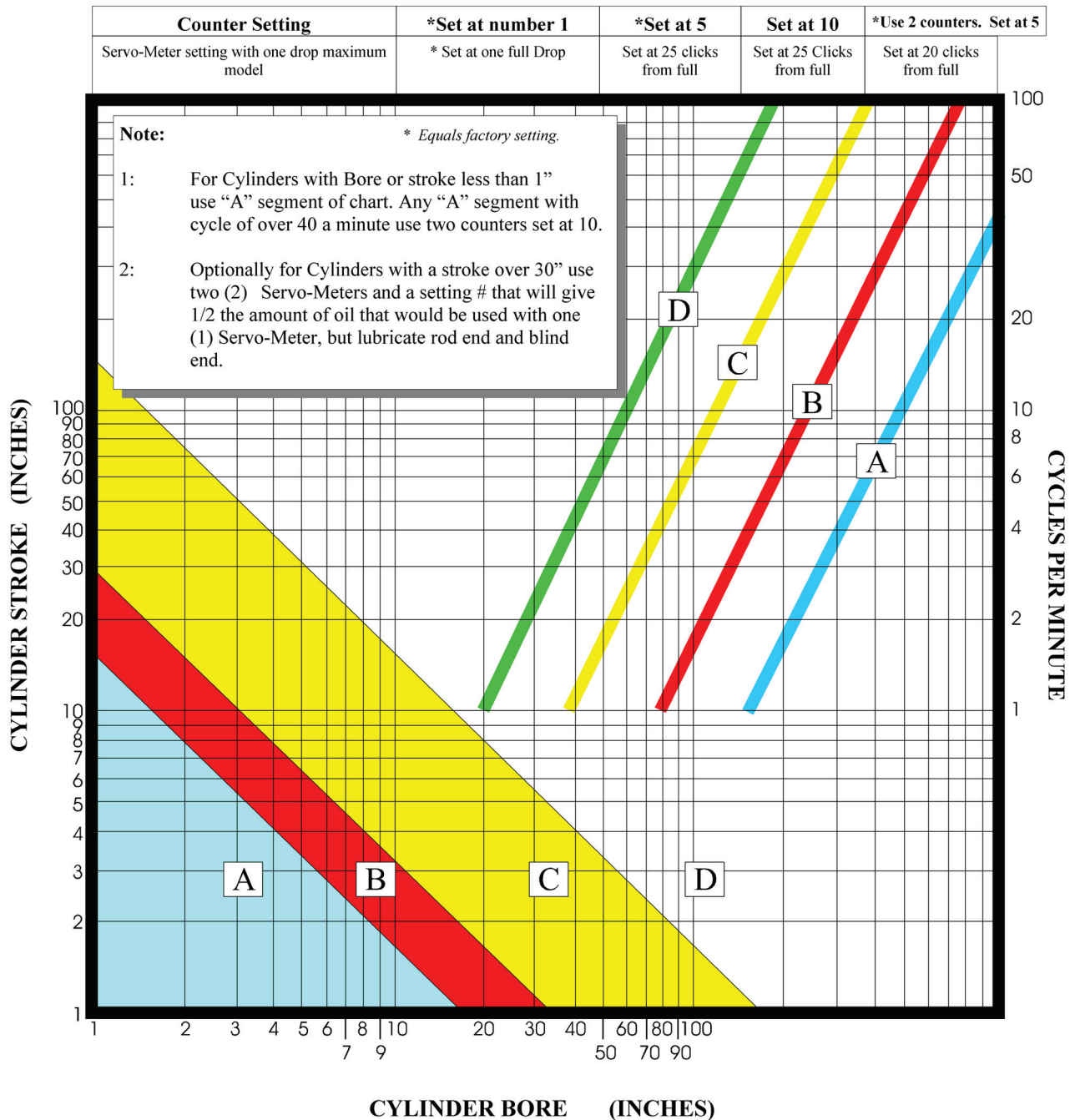

First identify where the bore and stroke intersect on the lower chart. With the appropriate letter use the cycles of the cylinder per minute and draw a line to intersect the A, B, C or D line on the upper chart. Draw a line vertically from there to the appropriate setting of the counter and Servo-Meter.

**Example:** Cylinder with 4" bore and 5" stroke falls into the "B" segment of the selection chart. If the operating rate of the cylinders is 15 per minute, the counter setting should be at 10 and the injector (*Servo-Meter*) knob turned counter - clockwise 25 clicks..

# SERIES 380 FRL ORDERING INFORMATION

The following ordering information must be used when options are required in addition to those shown on the **SERIES 380 FRL** pages of this catalog

Use the codes below to change the sample ordering number to specify the assembly you want.

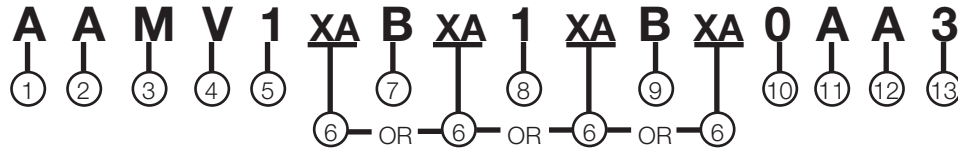

- ① **CAP COLOR**  
 Accent Grey ..... A  
 MP Yellow..... B  
 Red ..... C  
 Mid Blue..... D
- ② **BOWL TYPE** (See ⑩ for drain options.)  
 All plastic ..... A  
 All metal ..... B  
 Extended metal bowls on coalescing filter and  
 lubricator; standard metal bowl on G.P. filter ..... D
- ③ **CONNECTION**  
 Modular connectors ..... M  
 Pipe nipples..... P
- ④ **LOCKOUT VALVE**  
 V380 Lockout valve ..... V  
 No lockout valve ..... Remove V
- ⑤ **GENERAL PURPOSE FILTER** (See ⑩ for drain options.)  
 No general purpose filter..... 0  
 F380 (5- $\mu$ m element) ..... 1  
 CFR 380 (0-125 psig and 5- $\mu$ m element)..... 3  
 CFR 380-H (0-175 psig, metal dome, 5- $\mu$ m element) ..... 6  
 CFR 380-L (0-50 psig, 5- $\mu$ m element) ..... 8
- ⑥ **ADDITIONAL PORTS**  
 No port..... Remove XA  
 1/4 NPTF extra port only ..... X0  
 1/4 NPTF extra port, pressure/vacuum switch  
 PDA211-2, two 01986 plugs ..... XA  
 1/4 NPTF extra port, pressure/vacuum switch  
 PDA212-2, two 01986 plugs ..... XB  
 1/4 NPTF extra port, pressure/vacuum switch  
 PDA214-2, two 01986 plugs ..... XC  
 1/4 NPTF extra port, pressure/vacuum switch  
 PDA215-2, two 01986 plugs ..... XD  
 3/8 NPTF extra port only ..... XE  
 1/2 NPTF extra port only ..... XF  
 1/4 NPTF extra port, pressure/vacuum switch  
 PDA414-2, two 01986 plugs ..... XG  
 1/4 NPTF extra port, pressure/vacuum switch  
 PDA411-2, two 01986 plugs ..... XJ  
 1/4 NPTF extra port, pressure/vacuum switch  
 PDA413-2, two 01986 plugs ..... XK  
 Note: When an additional port will be included at either  
end of an assembly, you must select, from section 11.  
 Select an **INLET END** port if additional port is **FIRST**  
 component of the assembly. Select an **OUTLET END** port  
 if additional port is last component of the assembly.
- ⑦ **COALESCING FILTER** (See ⑩ for drain options. See  
 ⑫ for differential pressure gauge options.)  
 No coalescing filter ..... A  
 FC380 (0.3- $\mu$ m element) ..... B  
 FC380-E8 (0.01- $\mu$ m element) ..... C  
 FC380 (0.3- $\mu$ m element) and FC380-E9 (activated  
 carbon cartridge) ..... D  
 FC380-E8 (0.01- $\mu$ m element) and FC380-E9  
 (activated carbon cartridge) ..... E
- ⑧ **REGULATOR**  
 No regulator ..... 0  
 R380 (0-125 psig)..... 1  
 R380-H (0-175 psig and metal dome)..... 5\*  
 R380-L (0-50 psig) ..... 7  
 R380-T (0-125 psig and tee handle) ..... C
- ⑨ **LUBRICATOR**  
 No lubricator..... A  
 L380D ..... B  
 L380D-Q (with quick-fill Q-cap)..... C  
 PA64041 or PA64061 SPL and 118-109-\* male port.  
 (Used only with 1/2 or 3/4 ports and modular  
 connection M above) ..... D  
 PA64041 or PA64061 SPL. (Used only with 1/2 or 3/4  
 ports and pipe nipple connection P above.) ..... E  
 PA60041 or PA60061 SPL and 118-109-\* male port.  
 (Used only with 1/2 or 3/4 ports and modular  
 connection M above.) ..... F  
 PA60041 or PA60061 SPL. (Used only with 1/2 or 3/4  
 ports and pipe nipple connection P above.) ..... G  
 PA64045 or PA64065 SPL and 118-109-\* male port.  
 (Used only with 1/2 or 3/4 ports and modular  
 connection M above) ..... H  
 PA64045 or PA64065 SPL. (Used only with 1/2 or 3/4  
 ports and pipe nipple connection P above.) ..... J  
 PA60045 or PA60065 SPL and 118-109-\* male port.  
 (Used only with 1/2 or 3/4 ports and modular  
 connection M above.) ..... K  
 PA60045 or PA60065 SPL. (Used only with 1/2 or 3/4  
 ports and pipe nipple connection P above.) ..... L

**NOTE:** "P" prefix on injection lubricator part number indicates that it is supplied without capillary tubing. Instead a probe adapter will be supplied within the assembly.

\* H option spring includes metal dome.

*Continued on next page.*

# SERIES 380 FRL ORDERING INFORMATION

Continued from preceding page.

## 10 FILTER DRAINS

Manual on G.P. filter and coalescing filter .....	0
Internal automatic on G.P. filter and coalescing filter.....	1
Warrior electronic on G.P. filter and coalescing filter (Only with metal bowls) .....	2
Internal automatic on G.P. filter and manual on coalescing filter .....	5

None .....	None .....	Large DPG with None .....	NO reed switch.....	E
200-BDD (0-200 psi).....	Large DPG with NC reed switch .....	Large DPG with NC reed switch .....	Large DPG with NC reed switch.....	H
200-BDD (0-200 psi).....	None .....	Large DPG with None .....	NC reed switch.....	J
None .....	Large DPG with NC reed switch .....	Large DPG with None .....	NC reed switch.....	K
None .....	None .....	Large DPG with None .....	NC reed switch.....	L

## 11 INLET END PORT

## OUTLET END PORT

None .....	None .....	A
Female .....	Female .....	B
Male .....	Male .....	C
Male .....	Female .....	D
Female .....	Male .....	E
None .....	Female .....	F
None .....	Male .....	G
Female .....	None .....	H
Male .....	None .....	I
Back bracket only.....	Back bracket only .....	J
Female port with back bracket .....	Female port with back bracket .....	K
Back bracket only.....	Female port with back bracket .....	L
Female port with back bracket .....	Back bracket only .....	M
Male port with back bracket .....	Female port with back bracket .....	N

## 12 GAUGES:

DPG means Differential Pressure Gauge.  
NO means Normally Open.  
NC means Normally Closed.

Regulator	G.P. Filter	Coalescing Filter	
None .....	None .....	None .....	0
200-BDD (0-200 psi) .....	None .....	None .....	1
60BDD (0-60 psi).....	None .....	None .....	2
200-BDD (0-200 psi) . Small DPG.....	Small DPG .....	Small DPG .....	3
200-BDD (0-200 psi) . Large DPG.....	Large DPG .....	Large DPG .....	4
200-BDD (0-200 psi) .....	None .....	Small DPG .....	5
200-BDD (0-200 psi) .....	None .....	Large DPG .....	6
None .....	Small DPG .....	Small DPG .....	7
None .....	Large DPG.....	Large DPG .....	8
None .....	None .....	Small DPG .....	9
None .....	None .....	Large DPG .....	A
200-BDD (0-200 psi).....	Large DPG with NO reed switch ...	Large DPG with NO reed switch....	B
200-BDD (0-200 psi).....	None .....	Large DPG with NO reed switch....	C
None .....	Large DPG with NO reed switch ...	Large DPG with NO reed switch....	D

## 13 PORT SIZES

3/8 NPTF .....	3
1/2 NPTF .....	4
3/4 NPTF .....	6
3/8 BSPP .....	C
1/2 BSPP .....	D
3/4 BSPP .....	E
3/4-16 UNF SAE (Not available with end port options).....	F
7/8-14 UNF SAE (Not available with end port options).....	G

## SERIES 380 CUSTOMIZED INTERFACE

With this simple turned flange, users can easily customize their own products to interface directly with Series 380 modules using the clamp shown on page 275 (part number **A118-105**). See sketch below for dimensions.

Some potential usage examples are:

Turned Series 380 flange on a valve body.

Special threads such as SAE connections with Series 380 flange.

Special auxiliary manifold blocks having Series 380 flange configuration.

Suitable materials for a custom port include aluminum, brass, steel, stainless steel, and zinc.

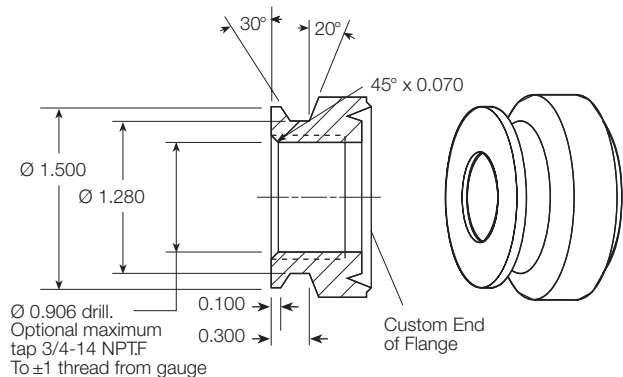

continued

# INDEX

## A

Adsorbers: See Filters, Adsorbing.  
Air Tool Lubrication ..... 202-205,  
214-217

## B

Block Plate (Serv-Oil) ..... 288  
Brackets, Mounting:  
FRL ..... 276  
Regulator ..... 276  
Series 380 ..... 275

## C

Cables, Electrical  
For Electro-pneumatic  
Servo-valve ..... 160  
For Pressure Sensors ..... 284  
Chain Lubrication, Viper ..... 236  
Check Valves:  
For Lubrication Tubing ..... 288  
V60 Models ..... 42  
Clean Air Packages  
With Series 70 Filters ..... 100  
With Series 380 Filters ..... 102  
Coalescing Filters  
See Filters, Coalescing.  
Connectors, Modular ..... 274-275  
Connectors for Tubing ..... 288  
Consolidated Filter/Regulators  
See Integral Filter/Regulators  
Coolant, PneuCool, Concentrate .... 289

## D

Delayed Pressure Buildup Valves  
General Information ..... 6-9  
V470 Models ..... 20  
V475 Models ..... 22  
V495 Models ..... 24  
With Lockout Control:  
V45M Models ..... 26  
V380 Models ..... 28  
V480 Models ..... 30  
V485 Models ..... 32  
Desiccants. See individual pages  
for MP-Filenco dryer-filters.  
Differential Pressure Gauges ..... 71  
Drains  
Ext. Float Actuated Drain ..... 280  
Hydro-Jector ..... 46-47  
Internal Automatic ..... 46  
Warrior Electronic ..... 281  
**Dryer/Filters, MP-Filenco**  
General Information ..... 94-95  
Series 25 ..... 104

(Continued)

Series 36, 38 ..... 106  
Series 418 ..... 108  
Series 625, 832 ..... 110

## F

Filter Drains  
External Float - Actuated Drain ..... 280  
Hydro-Jector ..... 46-47  
Internal Automatic ..... 46  
Warrior Electronic ..... 281  
Filter/Regulators:  
See Integral Filter/Regulators.  
Filters, Adsorbing  
General Information ..... 94  
BFC70-E9 Models ..... 96  
FC380-E9 Models ..... 98

Filters, Coalescing  
General Information ..... 70-71  
FCD10 Models ..... 72  
FCD50 Models ..... 74  
FCD60 Models ..... 76  
BFCD70 Models ..... 78  
FC101 Models ..... 80  
FCD101 Models ..... 84  
BFCD101 Models ..... 86, 88  
BFCD201 Models ..... 90, 92  
FCD380 Models ..... 82

Filters, General Purpose  
General Information ..... 44-47  
FD10 Models ..... 48  
FD50 Models ..... 50  
FD60 Models ..... 54  
BFD70 Models ..... 56  
FD100 Models ..... 58, 62  
BFD100 Models ..... 64  
BFD200 Models ..... 66  
FD380 Models ..... 60  
Stainless Steel:  
F50S Models ..... 52

Filters, Oil Removal:  
See Filters, Adsorbing.  
Filters, Particulate  
See Filters, General Purpose.  
Flow Control Valves:  
Right Angle V50 Models ..... 38  
Inline V55 Models ..... 40

FRLs  
Filter-Regulator-Lubricator  
Assemblies:  
General Information ..... 239  
VFDRL10, 11 Models ..... 254  
FDRL55, 56 Models ..... 256  
MVFDRL60D Models ..... 258  
BMVFDRL70D Models ..... 260  
MVFDRL108D Models ..... 262  
MVFDRL108W Models ..... 264  
FDRL180 Models ..... 268

(Continued)

FDRL189D Models ..... 270  
BFDRL289D Models ..... 272  
Series 380 Models ..... 267, 291  
Integral Filter/Regulators  
plus Lubricator Assemblies:  
General Information ..... 238  
VCFDRL10, 11 Models ..... 240  
CFDRL55, 56 Models ..... 242  
MVCFDRL60D Models ..... 244  
BMVCFDRL70D Models ..... 246  
MVCFDRL108D Models ..... 248  
MVCFDRL108W Models ..... 250  
Series 380 Models ..... 252, 291  
With Single-Point Lubricators:  
380 Assembly with Hose ..... 210-213  
Low Flow Assembly  
with Hose ..... 214-217

## G

Gauges, Differential Pressure ..... 71  
Gauges, Pressure ..... 277

## H

Hose Assemblies ..... 211-215

## I

Integral Filter/Regulators  
General Information ..... 162-163  
CFDR10M, CFDR11M Models ..... 164  
CFDR55M, CFDR56M Models ..... 166  
CFDR60 Models ..... 168  
BCFDR70 Models ..... 170  
CFDR100 Models ..... 172  
CFDR380 Models ..... 174  
Interface, Series 380 Custom ..... 291

## K

Kits  
Block Plate (Serv-Oil) ..... 288  
Filter Element Replacement. See  
pages for individual filters.  
Pulse Counter (Serv-Oil) ..... 288  
Seals for Servo-Meters ..... 287  
Tube-Away ..... 277

## L

Liquid Dispensers:  
See Scorpion Liquid Dispensers.  
Series 740, 770 ..... 224  
Series 750, 760 ..... 226

# INDEX

Lockout Valves  
General Information..... 6-7  
V10 Models ..... 10  
V35 Models ..... 12  
V40 Models ..... 14  
V450 Models ..... 16  
V460 Models ..... 18  
With Delayed Pressure Buildup:  
V45M Models ..... 26  
V380 Models ..... 28  
V470 Models ..... 20  
V480 Models ..... 30  
V485 Models ..... 32

Lubrication:  
Of Pneumatic Cylinders ...208-209, 290  
Of Pneumatic Tools ..... 202-203

Lubricators, Air Line:  
Also see Lubricators, Injection.  
General Information..... 176-177  
L10 Models..... 178  
L28D Models ..... 186  
L28W Models ..... 188  
L29D Models ..... 192  
L50, L50Y Models..... 180  
L60D Models ..... 182  
L70D Models ..... 184  
L100 Models..... 194  
BL237D Models..... 196  
L380D Models ..... 190

Lubricators, Injection  
Also see Lubricators, Air Line.  
Automation Pacs ..... 224  
Air Tool..... 210-217  
Block Plate ..... 288  
Chain Lubrication, Viper ..... 236  
Check Valves ..... 42  
Electronic Control Lubricators ..... 222  
FRLs with Single-Point  
Lubricators ..... 210-217  
General Information..... 198-201  
Multiple-Point Lubricators ..... 218-225  
Pulse Counter Kit ..... 288  
Reservoirs, Oil..... 287  
Seal Kits for Servo-Meters..... 288  
Servo-Meters ..... 199  
Servo-Meter Controllers ..... 200  
Single-Point Lubricators ..... 204, 206  
Tubing and Connectors..... 288  
Viper Chain Lubrcation..... 236

## M

Modular Accessories:  
Guardsmen models ..... 274  
Sentry models..... 274  
Series 380 ..... 275  
Vanguard models ..... 274

Mounting Brackets  
FRL..... 276  
Regulator ..... 276  
Series 380 ..... 275  
**Mufflers** ..... 277

## O

Oil Removal:  
See Filters, Adsorbing.  
Oil Reservoirs (Serv-Oil) ..... 287  
Ordering Information:  
**See individual product pages.**  
Series 380 FRLs ..... 291

## P

PneuCool Coolant Concentrate ..... 289  
Ports, Modular ..... 274, 275  
Pressure Gauges ..... 277  
Pressure Sensors, MPS ..... 284  
Pressure/Vacuum Switches ..... 282

## Q

Quick-Fill Cap (Q-cap) ..... 277

## R

Reclassifiers ..... 278  
Regulators, Pressure:  
Also see Integral Filter/Regulators.  
General Information..... 112-113  
Air Pressure Regulators:  
R10M, R11M Models ..... 114  
R55M, R56M Models..... 116  
R60 Models ..... 120  
R75 Models ..... 122  
R100 Models ..... 124  
R180M Models ..... 128  
R180 Models ..... 130  
R380 Models ..... 126  
Stainless Steel:  
R56S Models ..... 118  
External Pilot Regulators:  
PR56M Models ..... 140  
PR100 Models ..... 144  
PRH100 Models (high relief) ..... 146  
PR180M Models ..... 148  
PRH180M Models (high relief) ..... 150  
R200 Models ..... 152  
PR380 Models ..... 142  
Precision Regulators:  
R57 Models ..... 132  
IR100 Models ..... 136  
IR180M Models ..... 138  
IR380..... 134  
Water Pressure Regulators:  
R13M, R14M Models..... 154  
R53MB, R54MB Models ..... 156

Relief Valves ..... 158  
Reservoirs, Oil (Serv-Oil) ..... 287

## S

Scorpion Liquid Dispensers  
General Information..... 230-231  
800, 830, 850 Models..... 232  
890 Models (Scorpion Jr.) ..... 234  
Seal Kits for Servo-Meters ..... 288  
Serv-Oil Lubrication  
Also see Lubricators, Injection.  
Accessories ..... 288  
Automation Pacs ..... 224  
Check Valves for Tubing ..... 288  
General Information..... 198-201  
Injectors, Various..... 201  
Oil Reservoirs..... 287  
Scorpion Liquid Dispensers.... 226-229  
Servo-Meters ..... 199  
Servo-Meter Controllers ..... 200  
Seal Kits for Servo-Meters..... 288  
Tubing and Connectors..... 288  
Viper Chain Lubrication ..... 236  
Servo Valves ..... 160  
Shuttle Valves: SV20 Models ..... 36  
Silencer/Reclassifiers ..... 278  
Switches, Pressure/Vacuum ..... 285

## T

Tube-Away Kits ..... 277  
Tubing & Connectors ..... 288

## V

Valves. See:  
Check Valves  
Delayed Pressure Buildup Valves  
Flow Control Valves  
Lockout Valves  
Relief Valves  
Shuttle Valves  
Viper Chain Lubrication ..... 236

## W

Warranty ..... 2  
Warrior Drain ..... 281  
Water Pressure Regulators:  
See Regulators, Pressure.  
Water Removal ..... 47





6701 Eighteen Mile Rd  
Sterling Heights, MI 48314  
United States

Phone: (586) 254-1000  
Fax: (586) 254-6055

Website: [www.masterpneumatic.com](http://www.masterpneumatic.com)  
Email: [mp@masterpneumatic.com](mailto:mp@masterpneumatic.com)

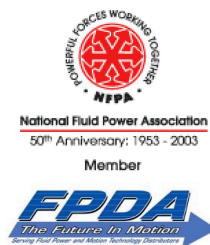

Issue: 09/07

Distributed By: